

For use with machines having Code Numbers: 70302

Safety Depends on You

Lincoln arc welding and cutting equipment is designed and built with safety in mind. However, your overall safety can be increased by proper installation ... and thoughtful operation on your part. **DO NOT INSTALL, OPERATE OR REPAIR THIS EQUIPMENT WITHOUT READING THIS MANUAL, AND THE SAETY PRECAUTIONS CONTAINED THROUGHOUT.** And, most importantly, think before you act and be careful.

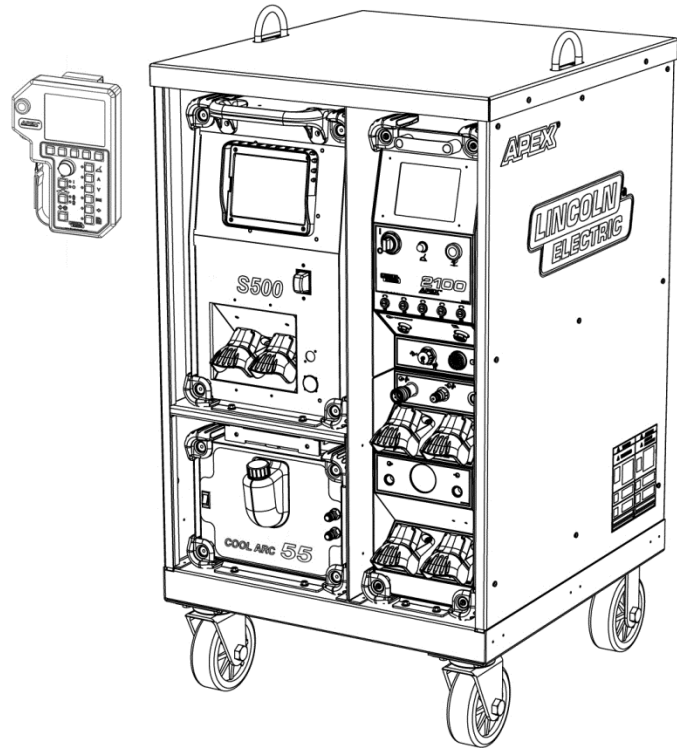

OPERATOR'S MANUAL



Copyright © Lincoln Global Inc.

⚠ WARNING

⚠ CALIFORNIA PROPOSITION 65 WARNINGS ⚠

Diesel engine exhaust and some of its constituents are known to the State of California to cause cancer, birth defects, and other reproductive harm.

The Above For Diesel Engines

The engine exhaust from this product contains chemicals known to the State of California to cause cancer, birth defects, or other reproductive harm.

The Above For Gasoline Engines

ARC WELDING CAN BE HAZARDOUS. PROTECT YOURSELF AND OTHERS FROM POSSIBLE SERIOUS INJURY OR DEATH. KEEP CHILDREN AWAY. PACEMAKER WEARERS SHOULD CONSULT WITH THEIR DOCTOR BEFORE OPERATING.

Read and understand the following safety highlights. For additional safety information, it is strongly recommended that you purchase a copy of "Safety in Welding & Cutting - ANSI Standard Z49.1" from the American Welding Society, P.O. Box 351040, Miami, Florida 33135 or CSA Standard W117.2-1974. A Free copy of "Arc Welding Safety" booklet E205 is available from the Lincoln Electric Company, 22801 St. Clair Avenue, Cleveland, Ohio 44117-1199.

BE SURE THAT ALL INSTALLATION, OPERATION, MAINTENANCE AND REPAIR PROCEDURES ARE PERFORMED ONLY BY QUALIFIED INDIVIDUALS.



FOR ENGINE powered equipment.

1.a. Turn the engine off before troubleshooting and maintenance work unless the maintenance work requires it to be running.



1.b. Operate engines in open, well-ventilated areas or vent the engine exhaust fumes outdoors.



1.c. Do not add the fuel near an open flame welding arc or when the engine is running. Stop the engine and allow it to cool before refueling to prevent spilled fuel from vaporizing on contact with hot engine parts and igniting. Do not spill fuel when filling tank. If fuel is spilled, wipe it up and do not start engine until fumes have been eliminated.

1.d. Keep all equipment safety guards, covers and devices in position and in good repair. Keep hands, hair, clothing and tools away from V-belts, gears, fans and all other moving parts when starting, operating or repairing equipment.

1.e. In some cases it may be necessary to remove safety guards to perform required maintenance. Remove guards only when necessary and replace them when the maintenance requiring their removal is complete. Always use the greatest care when working near moving parts.



1.f. Do not put your hands near the engine fan. Do not attempt to override the governor or idler by pushing on the throttle control rods while the engine is running.

1.g. To prevent accidentally starting gasoline engines while turning the engine or welding generator during maintenance work, disconnect the spark plug wires, distributor cap or magneto wire as appropriate.



1.h. To avoid scalding, do not remove the radiator pressure cap when the engine is hot.



ELECTRIC AND MAGNETIC FIELDS may be dangerous

2.a. Electric current flowing through any conductor causes localized Electric and Magnetic Fields (EMF). Welding current creates EMF fields around welding cables and welding machines

2.b. EMF fields may interfere with some pacemakers, and welders having a pacemaker should consult their physician before welding.

2.c. Exposure to EMF fields in welding may have other health effects which are now not known.

2.d. All welders should use the following procedures in order to minimize exposure to EMF fields from the welding circuit:

2.d.1. Route the electrode and work cables together - Secure them with tape when possible.

2.d.2. Never coil the electrode lead around your body.

2.d.3. Do not place your body between the electrode and work cables. If the electrode cable is on your right side, the work cable should also be on your right side.

2.d.4. Connect the work cable to the workpiece as close as possible to the area being welded.

2.d.5. Do not work next to welding power source.



ELECTRIC SHOCK can kill.

- 3.a. The electrode and work (or ground) circuits are electrically "hot" when the welder is on. Do not touch these "hot" parts with your bare skin or wet clothing. Wear dry, hole-free gloves to insulate hands.
- 3.b. Insulate yourself from work and ground using dry insulation. Make certain the insulation is large enough to cover your full area of physical contact with work and ground.

In addition to the normal safety precautions, if welding must be performed under electrically hazardous conditions (in damp locations or while wearing wet clothing; on metal structures such as floors, gratings or scaffolds; when in cramped positions such as sitting, kneeling or lying, if there is a high risk of unavoidable or accidental contact with the workpiece or ground) use the following equipment:

- Semiautomatic DC Constant Voltage (Wire) Welder.
 - DC Manual (Stick) Welder.
 - AC Welder with Reduced Voltage Control.
- 3.c. In semiautomatic or automatic wire welding, the electrode, electrode reel, welding head, nozzle or semiautomatic welding gun are also electrically "hot".
- 3.d. Always be sure the work cable makes a good electrical connection with the metal being welded. The connection should be as close as possible to the area being welded.
- 3.e. Ground the work or metal to be welded to a good electrical (earth) ground.
- 3.f. Maintain the electrode holder, work clamp, welding cable and welding machine in good, safe operating condition. Replace damaged insulation.
- 3.g. Never dip the electrode in water for cooling.
- 3.h. Never simultaneously touch electrically "hot" parts of electrode holders connected to two welders because voltage between the two can be the total of the open circuit voltage of both welders.
- 3.i. When working above floor level, use a safety belt to protect yourself from a fall should you get a shock.
- 3.j. Also see Items 6.c. and 8.



ARC RAYS can burn.

- 4.a. Use a shield with the proper filter and cover plates to protect your eyes from sparks and the rays of the arc when welding or observing open arc welding. Headshield and filter lens should conform to ANSI Z87.1 standards.
- 4.b. Use suitable clothing made from durable flame-resistant material to protect your skin and that of your helpers from the arc rays.
- 4.c. Protect other nearby personnel with suitable, non-flammable screening and/or warn them not to watch the arc nor expose themselves to the arc rays or to hot spatter or metal.



FUMES AND GASES can be dangerous.

- 5.a. Welding may produce fumes and gases hazardous to health. Avoid breathing these fumes and gases. When welding, keep your head out of the fume. Use enough ventilation and/or exhaust at the arc to keep fumes and gases away from the breathing zone. **When welding with electrodes which require special ventilation such as stainless or hard facing (see instructions on container or MSDS) or on lead or cadmium plated steel and other metals or coatings which produce highly toxic fumes, keep exposure as low as possible and within applicable OSHA PEL and ACGIH TLV limits using local exhaust or mechanical ventilation. In confined spaces or in some circumstances, outdoors, a respirator may be required. Additional precautions are also required when welding on galvanized steel.**
- 5.b. The operation of welding fume control equipment is affected by various factors including proper use and positioning of the equipment, maintenance of the equipment and the specific welding procedure and application involved. Worker exposure level should be checked upon installation and periodically thereafter to be certain it is within applicable OSHA PEL and ACGIH TLV limits.
- 5.c. Do not weld in locations near chlorinated hydrocarbon vapors coming from degreasing, cleaning or spraying operations. The heat and rays of the arc can react with solvent vapors to form phosgene, a highly toxic gas, and other irritating products.
- 5.d. Shielding gases used for arc welding can displace air and cause injury or death. Always use enough ventilation, especially in confined areas, to insure breathing air is safe.
- 5.e. Read and understand the manufacturer's instructions for this equipment and the consumables to be used, including the material safety data sheet (MSDS) and follow your employer's safety practices. MSDS forms are available from your welding distributor or from the manufacturer.
- 5.f. Also see item 1.b.

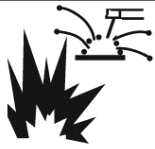

WELDING and CUTTING SPARKS can cause fire or explosion.

6.a. Remove fire hazards from the welding area. If this is not possible, cover them to prevent the welding sparks from starting a fire.

Remember that welding sparks and hot materials from welding can easily go through small cracks and openings to adjacent areas. Avoid welding near hydraulic lines. Have a fire extinguisher readily available.

- 6.b. Where compressed gases are to be used at the job site, special precautions should be used to prevent hazardous situations. Refer to "Safety in Welding and Cutting" (ANSI Standard Z49.1) and the operating information for the equipment being used.
- 6.c. When not welding, make certain no part of the electrode circuit is touching the work or ground. Accidental contact can cause overheating and create a fire hazard.
- 6.d. Do not heat, cut or weld tanks, drums or containers until the proper steps have been taken to insure that such procedures will not cause flammable or toxic vapors from substances inside. They can cause an explosion even though they have been "cleaned". For information, purchase "Recommended Safe Practices for the Preparation for Welding and Cutting of Containers and Piping That Have Held Hazardous Substances", AWS F4.1 from the American Welding Society (see address above).
- 6.e. Vent hollow castings or containers before heating, cutting or welding. They may explode.
- 6.f. Sparks and spatter are thrown from the welding arc. Wear oil free protective garments such as leather gloves, heavy shirt, cuffless trousers, high shoes and a cap over your hair. Wear ear plugs when welding out of position or in confined places. Always wear safety glasses with side shields when in a welding area.
- 6.g. Connect the work cable to the work as close to the welding area as practical. Work cables connected to the building framework or other locations away from the welding area increase the possibility of the welding current passing through lifting chains, crane cables or other alternate circuits. This can create fire hazards or overheat lifting chains or cables until they fail.
- 6.h. Also see item 1.c.
- 6.i. Read and follow NFPA 51B "Standard for Fire Prevention During Welding, Cutting and Other Hot Work", available from NFPA, 1 Batterymarch Park, PO box 9101, Quincy, Ma 022690-9101.
- 6.j. Do not use a welding power source for pipe thawing.



CYLINDER may explode if damaged.

7.a. Use only compressed gas cylinders containing the correct shielding gas for the process used and properly operating regulators designed for the gas and pressure used. All hoses, fittings, etc. should be suitable for the application and maintained in good condition.

- 7.b. Always keep cylinders in an upright position securely chained to an undercarriage or fixed support.
- 7.c. Cylinders should be located:
 - Away from areas where they may be struck or subjected to physical damage.
 - A safe distance from arc welding or cutting operations and any other source of heat, sparks, or flame.
- 7.d. Never allow the electrode, electrode holder or any other electrically "hot" parts to touch a cylinder.
- 7.e. Keep your head and face away from the cylinder valve outlet when opening the cylinder valve.
- 7.f. Valve protection caps should always be in place and hand tight except when the cylinder is in use or connected for use.
- 7.g. Read and follow the instructions on compressed gas cylinders, associated equipment, and CGA publication P-1, "Precautions for Safe Handling of Compressed Gases in Cylinders," available from the Compressed Gas Association 1235 Jefferson Davis Highway, Arlington, VA 22202.



FOR ELECTRICALLY powered equipment.

- 8.a. Turn off input power using the disconnect switch at the fuse box before working on the equipment.
- 8.b. Install equipment in accordance with the U.S. National Electrical Code, all local codes and the manufacturer's recommendations.
- 8.c. Ground the equipment in accordance with the U.S. National Electrical Code and the manufacturer's recommendations.

Refer to <http://www.lincolnelectric.com/safety> for additional safety information.

PRÉCAUTIONS DE SÛRETÉ

Pour votre propre protection lire et observer toutes les instructions et les précautions de sûreté spécifiques qui paraissent dans ce manuel aussi bien que les précautions de sûreté générales suivantes:

Sûreté Pour Soudage A L'Arc

1. Protégez-vous contre la secousse électrique:
 - a. Les circuits à l'électrode et à la pièce sont sous tension quand la machine à souder est en marche. Eviter toujours tout contact entre les parties sous tension et la peau nue ou les vêtements mouillés. Porter des gants secs et sans trous pour isoler les mains.
 - b. Faire très attention de bien s'isoler de la masse quand on soude dans des endroits humides, ou sur un plancher métallique ou des grilles métalliques, principalement dans les positions assis ou couché pour lesquelles une grande partie du corps peut être en contact avec la masse.
 - c. Maintenir le porte-électrode, la pince de masse, le câble de soudage et la machine à souder en bon et sûr état de fonctionnement.
 - d. Ne jamais plonger le porte-électrode dans l'eau pour le refroidir.
 - e. Ne jamais toucher simultanément les parties sous tension des porte-électrodes connectés à deux machines à souder parce que la tension entre les deux pinces peut être le total de la tension à vide des deux machines.
 - f. Si on utilise la machine à souder comme une source de courant pour soudage semi-automatique, ces précautions pour le porte-électrode s'appliquent aussi au pistolet de soudage.
2. Dans le cas de travail au dessus du niveau du sol, se protéger contre les chutes dans le cas où on reçoit un choc. Ne jamais enrouler le câble-électrode autour de n'importe quelle partie du corps.
3. Un coup d'arc peut être plus sévère qu'un coup de soliel, donc:
 - a. Utiliser un bon masque avec un verre filtrant approprié ainsi qu'un verre blanc afin de se protéger les yeux du rayonnement de l'arc et des projections quand on soude ou quand on regarde l'arc.
 - b. Porter des vêtements convenables afin de protéger la peau de soudeur et des aides contre le rayonnement de l'arc.
 - c. Protéger l'autre personnel travaillant à proximité au soudage à l'aide d'écrans appropriés et non-inflammables.
4. Des gouttes de laitier en fusion sont émises de l'arc de soudage. Se protéger avec des vêtements de protection libres de l'huile, tels que les gants en cuir, chemise épaisse, pantalons sans revers, et chaussures montantes.

5. Toujours porter des lunettes de sécurité dans la zone de soudage. Utiliser des lunettes avec écrans latéraux dans les zones où l'on pique le laitier.
6. Eloigner les matériaux inflammables ou les recouvrir afin de prévenir tout risque d'incendie dû aux étincelles.
7. Quand on ne soude pas, poser la pince à un endroit isolé de la masse. Un court-circuit accidentel peut provoquer un échauffement et un risque d'incendie.
8. S'assurer que la masse est connectée le plus près possible de la zone de travail qu'il est pratique de le faire. Si on place la masse sur la charpente de la construction ou d'autres endroits éloignés de la zone de travail, on augmente le risque de voir passer le courant de soudage par les chaînes de levage, câbles de grue, ou autres circuits. Cela peut provoquer des risques d'incendie ou d'échauffement des chaînes et des câbles jusqu'à ce qu'ils se rompent.
9. Assurer une ventilation suffisante dans la zone de soudage. Ceci est particulièrement important pour le soudage de tôles galvanisées plombées, ou cadmiées ou tout autre métal qui produit des fumées toxiques.
10. Ne pas souder en présence de vapeurs de chlore provenant d'opérations de dégraissage, nettoyage ou pistilage. La chaleur ou les rayons de l'arc peuvent réagir avec les vapeurs du solvant pour produire du phosgène (gas fortement toxique) ou autres produits irritants.
11. Pour obtenir de plus amples renseignements sur la sûreté, voir le code "Code for safety in welding and cutting" CSA Standard W 117.2-1974.

PRÉCAUTIONS DE SÛRETÉ POUR LES MACHINES À SOUDER À TRANSFORMATEUR ET À REDRESSEUR

1. Relier à la terre le châssis du poste conformément au code de l'électricité et aux recommandations du fabricant. Le dispositif de montage ou la pièce à souder doit être branché à une bonne mise à la terre.
2. Autant que possible, l'installation et l'entretien du poste seront effectués par un électricien qualifié.
3. Avant de faire des travaux à l'intérieur de poste, la débrancher à l'interrupteur à la boîte de fusibles.
4. Garder tous les couvercles et dispositifs de sûreté à leur place.

Thank You

for selecting a **QUALITY** product by Lincoln Electric. We want you to take pride in operating this Lincoln Electric Company product
••• as much pride as we have in bringing this product to you!

CUSTOMER ASSISTANCE POLICY

The business of The Lincoln Electric Company is manufacturing and selling high quality welding equipment, consumables, and cutting equipment. Our challenge is to meet the needs of our customers and to exceed their expectations. On occasion, purchasers may ask Lincoln Electric for advice or information about their use of our products. We respond to our customers based on the best information in our possession at that time. Lincoln Electric is not in a position to warrant or guarantee such advice, and assumes no liability, with respect to such information or advice. We expressly disclaim any warranty of any kind, including any warranty of fitness for any customer's particular purpose, with respect to such information or advice. As a matter of practical consideration, we also cannot assume any responsibility for updating or correcting any such information or advice once it has been given, nor does the provision of information or advice create, expand or alter any warranty with respect to the sale of our products.

Lincoln Electric is a responsive manufacturer, but the selection and use of specific products sold by Lincoln Electric is solely within the control of, and remains the sole responsibility of the customer. Many variables beyond the control of Lincoln Electric affect the results obtained in applying these types of fabrication methods and service requirements.

Subject to Change – This information is accurate to the best of our knowledge at the time of printing. Please refer to www.lincolnelectric.com for any updated information.

Please Examine Carton and Equipment For Damage Immediately

When this equipment is shipped, title passes to the purchaser upon receipt by the carrier. Consequently, Claims for material damaged in shipment must be made by the purchaser against the transportation company at the time the shipment is received.

Please record your equipment identification information below for future reference. This information can be found on your machine nameplate.

Product _____

Model Number _____

Code Number or Date Code _____

Serial Number _____

Date Purchased _____

Where Purchased _____

Whenever you request replacement parts or information on this equipment, always supply the information you have recorded above. The code number is especially important when identifying the correct replacement parts.

On-Line Product Registration

- Register your machine with Lincoln Electric either via fax or over the Internet.
 - For faxing: Complete the form on the back of the warranty statement included in the literature packet accompanying this machine and fax the form per the instructions printed on it.
 - For On-Line Registration: Go to our **WEB SITE at www.lincolnelectric.com**. Choose "Support" and then "Register Your Product". Please complete the form and submit your registration.

Read this Operators Manual completely before attempting to use this equipment. Save this manual and keep it handy for quick reference. Pay particular attention to the safety instructions we have provided for your protection. The level of seriousness to be applied to each is explained below:

WARNING

This statement appears where the information **must** be followed **exactly** to avoid **serious personal injury** or **loss of life**.

CAUTION

This statement appears where the information **must** be followed to avoid **minor personal injury** or **damage to this equipment**.

TABLE OF CONTENTS

TABLE OF CONTENTS

TABLE OF CONTENTS	vi	CABLE ASSEMBLIES	10
TABLE OF FIGURES	vi	OPERATION	12
BASIC INFORMATION	1	PENDANT	12
OVERVIEW	1	Display	12
ARC VOLTAGE CONTROL THEORY	1	Navigation	13
CONTROL COMPONENTS	2	Selection	13
APEX 2100	2	Encoder	13
PENDANT ASSEMBLY	2	Control	13
CABINET ASSEMBLY	2	Selection Images	13
WELDING POWER SOURCE	2	Power on Initial Screen	14
WATER COOLER	2	Program Selection Screen	14
WELD HEAD ASSEMBLY	2	BEGIN WELDING	15
PROCESS TIME LINE	2	JOG MENU	15
OSCILLATOR DESCRIPTION	4	WELD SCREEN	17
OSCILLATOR WIDTH	4	AMPS SCREEN	18
OSCILLATOR CENTER	4	VOLTAGE SCREEN	20
CENTER/ WIDTH INTERACTION	4	OSCILLATOR SCREEN	22
IN & OUT DWELL	5	WIRE SCREEN	23
EXCURSION SPEED	5	SETUP SCREEN	24
TAPER	5	MENUS SCREEN	27
STRAIGHT AMPERAGE	5	MAINTENANCE	33
AMPERAGE PULSING	5	Power Wave S500	33
ARC VOLTAGE CONTROL	6	Water Cooler	33
MODES OF OPERATION	6	Control Unit Assembly	33
VOLTAGE ADJUSTEMENT CONTROLS	6	Cable Assembly	34
WIRE FEED	7	Weld Head Assembly	34
SYNC TO PULSE	7	Preventative Maintenance Schedule	34
PRIMARY WIRE SPEED	7	Monthly Maintenance	34
BACKGROUND WIRE SPEED	7	Weld Head Assemblies	34
CONTINUOUS	7	Quarterly Maintenance	34
INSTALLATION	8	Cables	34
TECHNICAL SPECIFICATIONS	8	Semi Annual Maintenance	35
TRACTOR INSTALLATION	10	Control Unit Assembly	35
BASIC INFORMATION	10	Calibration	35
		SOFTWARE CALIBRATION	35
		PARTS LIST	40
		Index	65

TABLE OF CONTENTS

TABLE OF FIGURES

Figure 1 – CONTROL UNIT	2
Figure 2 – ORBITAL PROCESS TIMELINE	3
Figure 3 – CENTER/WIDTH INTERACTION	4
Figure 4 – TAPER FUNCTION.....	5
Figure 5 – INDEPENDENT PULSE WAVEFORM	5
Figure 6 – SYNC TO OSCILLATION WAVEFORM	6
Figure 7 – DEADBAND EXAMPLE	6
Figure 8 – WIRE FEED SYNC TO PULSE	7
Figure 9 – WIRE SPEED SYNC TO OSCILLATION (AMPS).....	7
Figure 10 – CABLE MAP COMPLETE SYSTEM.....	9
Figure 11 – CABLE MAP FRONT	10
Figure 12 – CABLE MAP BACK.....	11
Figure 13 – PENDANT	12
Figure 14 – INITIAL POWER SCREEN	14
Figure 15 – PROGRAM SELECTION SCREEN	14
Figure 16 – JOG MENU SCREEN WIRE.....	15
Figure 17 – TRAVEL BUTTON	15
Figure 18 – JOG MENU SCREEN TRAVEL	16
Figure 19 – WELD SCREEN.....	17
Figure 20 – WELD SCREEN BACKGROUND	17
Figure 21 – AMPS SCREEN PULSED ARC	18
Figure 22 -- AMPS SCREEN PULSED ARC STEP TRAVEL	19
Figure 23 – TRAVEL EXAMPLES.....	19
Figure 24 – AMPS SCREEN SYNC PULSE	19
Figure 25 – AMPS SCREEN NO PULSE.....	19
Figure 26 – VOLTAGE SCREEN SAMPLED CONTINUOUS	20
Figure 27 – VOLTAGE SCREEN SAMPLED PRIMARY	20
Figure 28 – VOLTAGE SCREEN SAMPLED BACKGROUND	20
Figure 29 – OSCILLATOR SCREEN	22
Figure 30 – WIRE SCREEN SYNC TO PULSE	23
Figure 31 – WIRE SCREEN CONTINUOUS	23
Figure 32 – SETUP SCREEN	24
Figure 33 – SETUP SCREEN OPTIONS.....	24
Figure 34 – SAVE PARAMETERS DATA.....	25
Figure 35 – LOAD SCREEN SCROLL PROGRAMS.....	25
Figure 36 – SAVE SCREEN.....	25
Figure 37 – CALIBRATION SCREEN	26
Figure 38 – TOOLS	26
Figure 39 – CODES LIBRARY	27
Figure 40 – MENUS SCREEN	27
Figure 41 – START OF WELD	28
Figure 42 – END OF WELD	29
Figure 43 – ACCESS CONTROL LIST	30
Figure 44 – FIRMWARE REVISION	30
Figure 45 – FAULT MONITORING	31
Figure 46 – OVERRIDE SETTINGS	31
Figure 47 – INCREMENT VALUES	31
Figure 48 – SYSTEM HEALTH INFORMATION.....	32
Figure 49 – APEX 2100 WIRING DIAGRAM	39

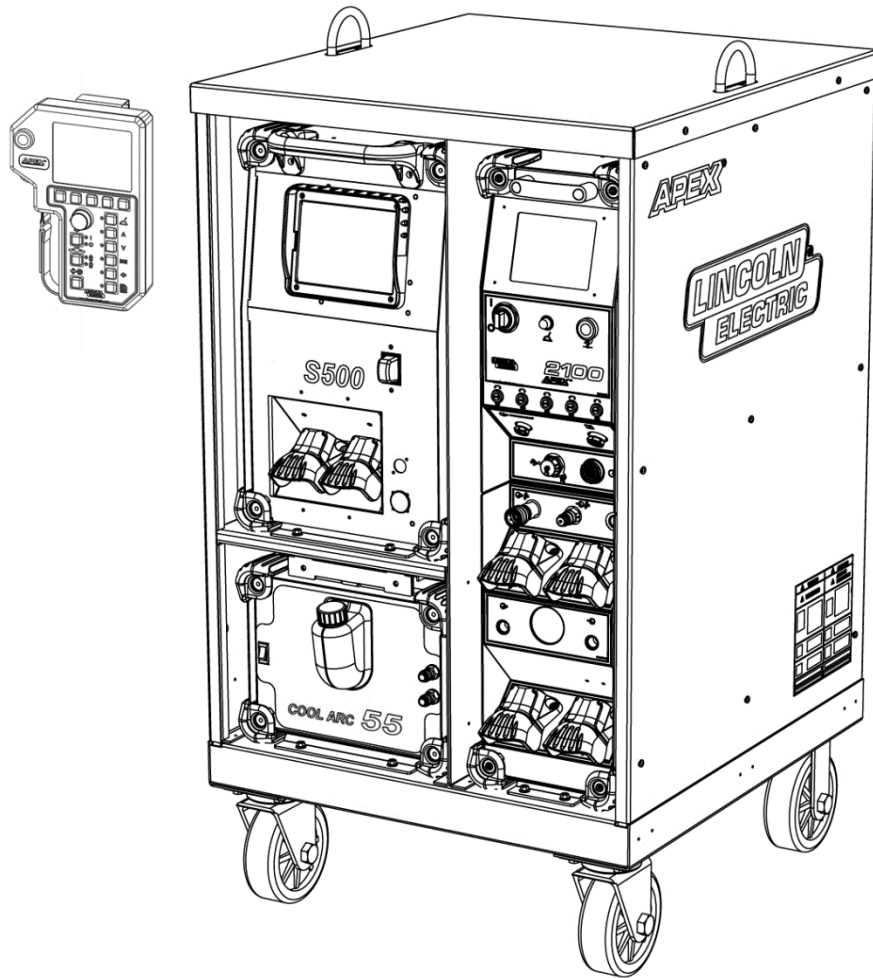

ORBITAL CONTROL SYSTEM

BASIC INFORMATION

OVERVIEW

The APEX 2100 Orbital Control System is a precision microprocessor-controller for use with the Gas Tungsten Arc Welding process (GTAW), also known as Tungsten Inert Gas (TIG) Welding.

The controller's design provides precision control over a GTAW Orbital Welding process which has strict parameters that must be maintained to meet the requirements demanded of power plants, chemical plants, refineries, pharmaceutical manufacturers, wineries, breweries, etc.

This control system is made up of several components each providing a specific task to the overall system. The principle components are: the controller, pendant, weld head, welding power source, water cooler, and a system cabinet.

The controller houses: the power board, two motor control boards and a control board. The power board is used to power all of the other boards in the system. One of the motor control boards controls Rotation and Wire feed motors, and the other controls the AVC and Oscillation motors. The control board handles all communication from the operator / welder, via the pendant assembly, and provides command and control parameters for the other boards and components of the system.

The welding power source control functions are limited to a contract closure to enable the welding output and an analog voltage value from 0 to 10VDC.

The weld head automatically makes corrections to match the arc voltage set on the pendant, which keeps the arc length constant.

The controller has an LCD display that gives a mirror image of Pendant's display.

The pendant assembly is the primary user interface to the controller. The pendant has Navigation buttons and Selection buttons to navigate the menus displayed on the pendant's LCD screen, and an encoder used to adjust the values of all the parameters necessary for proper control of the welding process.

There are dedicated Control Buttons for Wire Feed, Travel Direction, and a Start / Stop button which begins or terminates the welding process.

An Emergency Stop button is located on the top left hand side of the Pendant which will terminate all welding applications.

ARC VOLTAGE CONTROL THEORY

Tungsten Inert Gas (TIG) Welding is an arc welding process that uses a tungsten electrode to produce the weld. The weld area is protected from atmospheric contamination by a shielding gas, usually an inert gas such as argon. The constant current welding power supply produces energy which is conducted across the arc through a column of highly ionized gas and metal vapors known as plasma. If the voltage is not kept constant, the heat (or power) into the piece being welded is not kept constant which results in inferior welds.

To provide the high quality and consistency required of automatic TIG Welding, an Arc Voltage Control (AVC) system is required. The AVC system in the APEX 2100 provides this required control.

To initiate an arc without High Frequency, a lift arc process is used. This enables reliable, automated non-High-Frequency (HF) arc starting on all metals. The AVC commands the torch to touch the work-piece and preheat the tungsten. Once the tungsten is heated, the AVC Control system breaks contact between the tungsten and the work-piece creating the arc. This provides a smooth, consistent arc start, without tungsten inclusion.

Many factors affect the voltage created from a welding arc. They include:

- tungsten to work distance
- tungsten shape
- welding current level
- shielding gas changes
- and others

These variables are monitored by the AVC which checks the voltages at specific times and compares them to the input weld parameters. The AVC adjusts the arc length or the tungsten to work distance, keeping the Voltage at the optimal level for a smooth and consistent weld.

CONTROL COMPONENTS

APEX 2100

The Apex 2100 consists of a control unit and pendant. The control unit contains electronic circuitry use solid state circuits which provide long, trouble free operation and is surrounded by a heavy gauge steel enclosure. The control unit operates on 115/230 VAC, 50/60 Hz commercial power, capable of drawing up to 5 amps peak current. Input power is supplied by a Lincoln Power Wave S500.

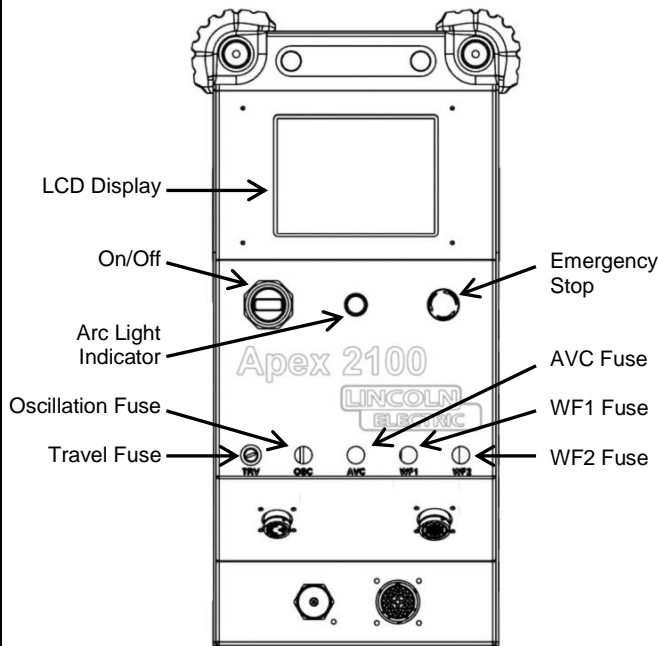

FIGURE 1 – CONTROL UNIT

The controller contains 6 PCBs; the Power Module board, Control board, Monitor board, Rotation & Wire board, AVC & Oscillator board, and LCD board which is mounted on the front panel.

The Control Unit section has three connectors on the front of the unit for the Pendant Assembly, the Power Source, and the Weld Head. There is a power switch on the front panel that lights up when power is on, a USB port, and a fuse holder mounted at the rear of the controller for input power protection, as well as five fuses on the front panel to protect the motors (see Figure 1 - Control Unit).

The Monitor / Sensor section on the bottom of the control assembly houses the gas, water and monitors valid arc signals, relaying these signals to the controller. The gas and water sensors are used to

monitor flow and set alarms or even terminate the welding process if the flow is out of an acceptable flow range.

PENDANT ASSEMBLY

The pendant assembly is the primary user interface. All parameters and features of the controller are entered or selected from this pendant.

To make changes in parameters or enable or disable features of the control system, the operator uses Navigation buttons, Selection buttons, and an Encoder to cycle through the different controller menus to set up for individual welds. The menus are shown on the LCD Display.

A Start / Stop button and an Emergency Stop button are incorporated to initiate or terminate the welding process.

CABINET ASSEMBLY

The cabinet assembly is a broad term used to describe the housing for the power source, water cooler, and the control unit.

WELDING POWER SOURCE

The welding power source used in this system is a Power Wave S500, K2904-1.

WATER COOLER

The water cooler is a Cool Arc 55, K3086-1.

WELD HEAD ASSEMBLY

The weld head used with this system is a T55 Helix, K52002-1.

At the time of this publication the T55 is our standard weld head.

PROCESS TIME LINE

The Orbital welding process is complicated with many items starting and stopping at different times throughout the welding cycle. To help eliminate any confusion, a timeline (see Figure 2 – Orbital Process Timeline) was developed to assist in the understanding of this system and its processes.

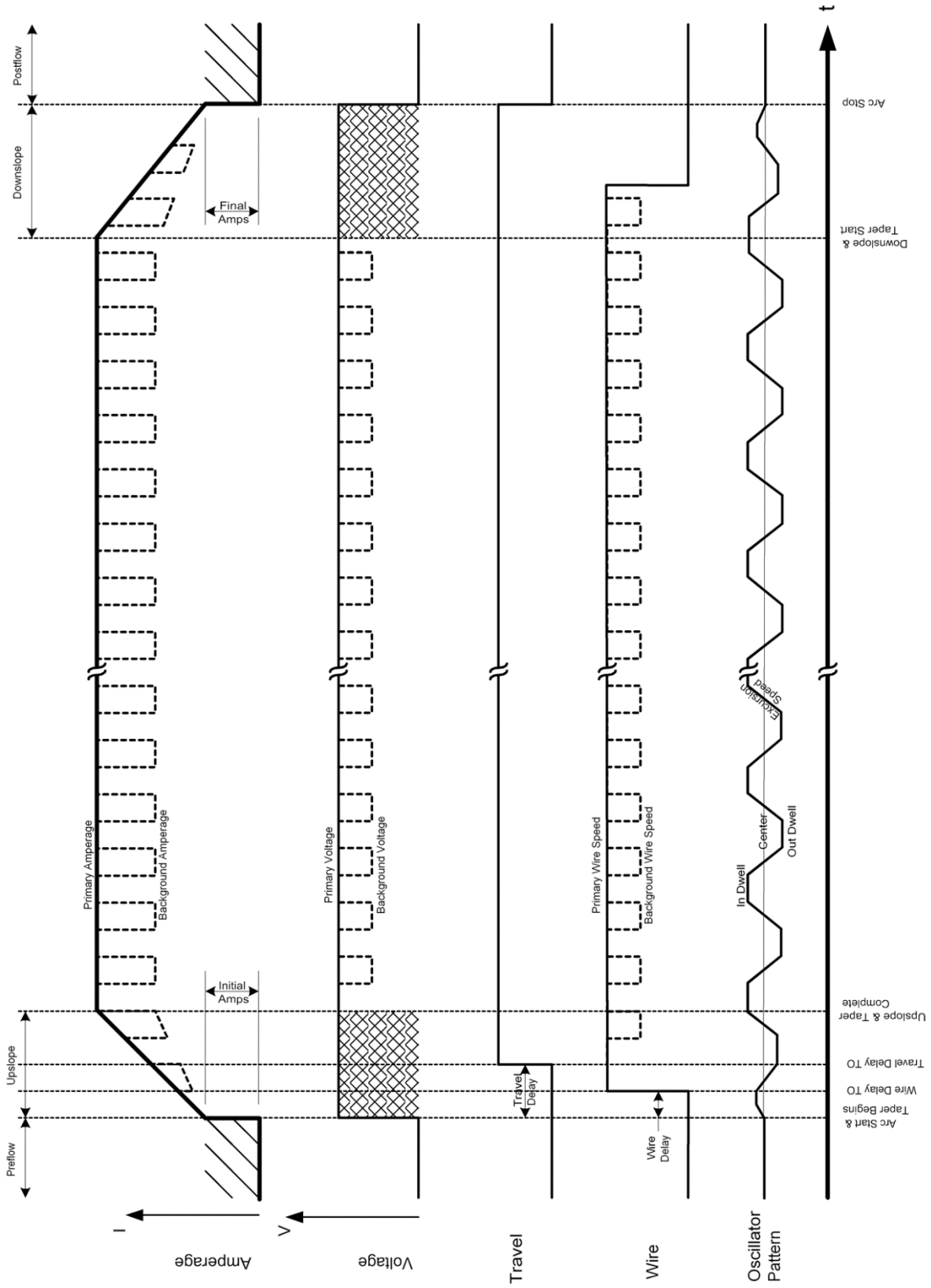

FIGURE 2 – ORBITAL PROCESS TIMELINE

OSCILLATOR DESCRIPTION

The Oscillator provides several benefits for welding in deep groove applications and cover passes. The oscillator's primary benefit is to provide consistent and reliable arc placement preventing heat from being concentrated in one location. In addition, weld bead and weld contouring are easily implemented using the oscillation feature.

There are five parameters required to setup and control the oscillator: Oscillator Center, Oscillation Width, In Dwell, Out Dwell, and Excursion Speed.

OSCILLATOR WIDTH

Oscillation Width is how wide the torch travels while oscillating. The controller provides an Oscillator Width of 1 inch.

It is not possible to set a width greater than the controller allows (1 inch) or greater than the distance from Center to one of the physical limits. The minimum oscillator width is .015 inch.

OSCILLATOR CENTER

The Oscillator Center is a variable value which allows the operator to set the center point of oscillation. When Oscillation is off, Oscillator Center acts as steering allowing the operator to guide the torch to a precise position.

CENTER/ WIDTH INTERACTION

Center and Width have a direct effect on each other. In Figure 3 there are three examples of how Center and Width effect each other. The first image shows that with 1 inch width of Oscillation the Center Position must be set at 0. The second image shows that with a width of 0.8 of Oscillation the Center point can vary between 0.1 to -0.1. The final image shows that with a width of 0.4 Oscillation center can be anywhere from 0.3 to -0.3.

The larger the width the smaller possible area for the center position; likewise the closer the Center position gets to one of the physical limits the smaller the Width.

Center Effects Width

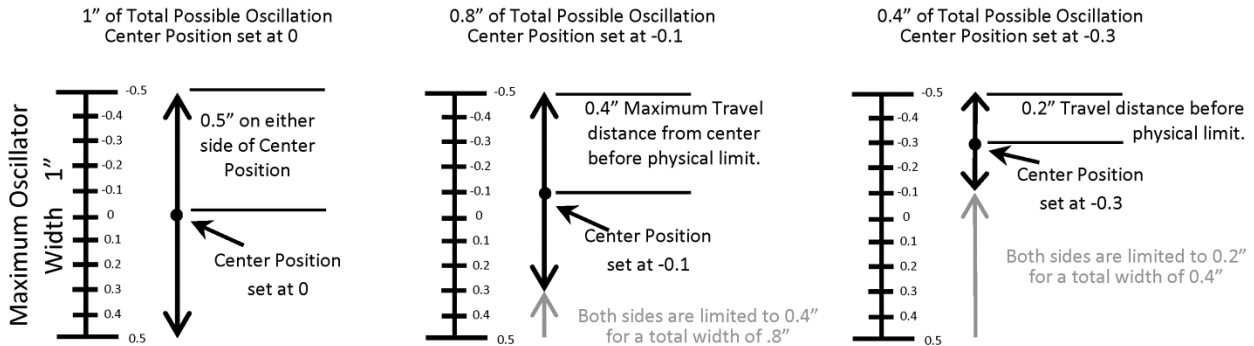

Width Effects Center

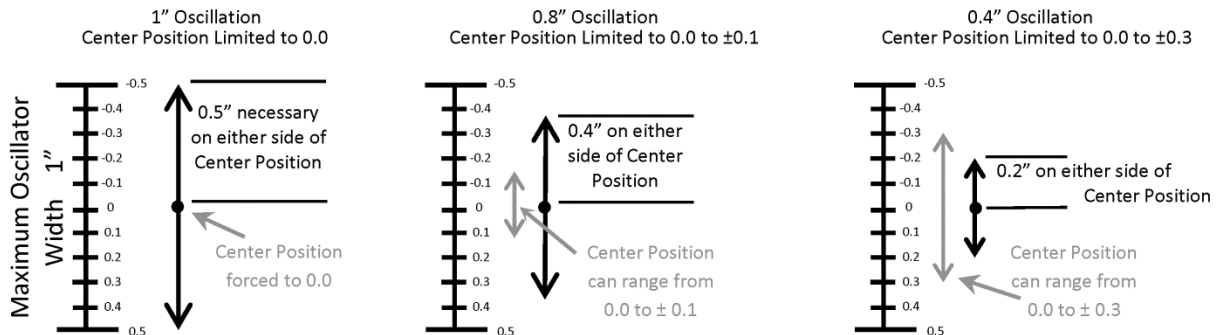

FIGURE 3 – CENTER/WIDTH INTERACTION

NOTE

Care should be taken to ensure Width adjustment is not set greater than the actual weld joint opening to prevent torch and other damage.

IN & OUT DWELL

The primary purpose of In and Out Dwell is to allow proper heat into the sidewalls of the weld joint.

The Dwell adjustment controls the time at each end of the oscillation width. The In Dwell controls the time of the Dwell at the limit near (or toward) the weld head, whereas the Out Dwell controls the opposite limit. This adjustment is in seconds and can range from 0 (no time spent on Dwell) to 99.9 seconds.

EXCURSION SPEED

Excursion speed, which offers greater control over the bead shape and heat input into the base material, is the transition speed from one side of oscillation to the other. Excursion Speed is measured in seconds from 0.1 to 4.

TAPER

Taper allows the operator to gradually increase the Oscillation Width from the Center position to the desired Oscillation Width during upslope. Likewise, during downslope, where the most noticeable change in the width appearance occurs, the Taper function reduces the oscillation width over the downslope time to reduce the weld bead at the end of the cycle (see Figure 4 – Taper Function). The taper function is automatically implemented on each upslope and downslope of the weld cycle.

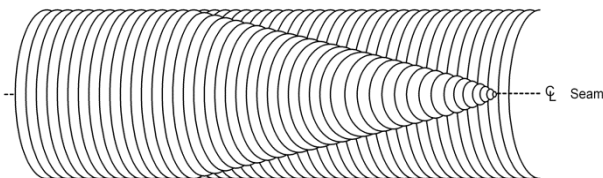
**FIGURE 4 – TAPER FUNCTION**

Like amperage downslope, the major benefit to the arc and the weld joint is to prevent thermal shock to the base material by reducing the amperage from a high amperage, to a lower final amperage at the end of the downslope time.

WELD AMPERAGE MODES

There are two weld amperage modes, Straight Amperage and Amperage Pulsing.

STRAIGHT AMPERAGE

The orbital controller can provide a straight DC output amperage to the torch, no pulsing at all. The Primary Amperage is the only amperage value to adjust, with the exception of Starting Amperage and Final Amperage.

In this mode, the controller will command a steady amperage throughout the welding cycle.

AMPERAGE PULSING

The orbital controller can provide a pulsed amperage weld output in two methods, Independent Pulse and Sync to Oscillation.

Independent pulse

Independent Pulse creates a pulsed amperage output made up of four variables, Primary Amps, Background Amps, Primary Width and (PPS) Pulses per Second (see Figure 5 – Independent Pulse Waveform).

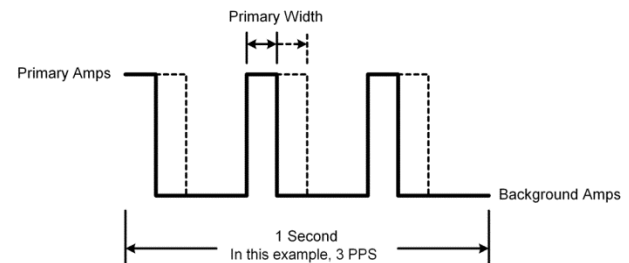
**FIGURE 5 – INDEPENDENT PULSE WAVEFORM**

Primary Amps - sets the amperage level at the top or at the peak of the pulse.

Background Amps –sets the amperage level at the bottom of the pulse.

Primary Width - adjusts the percentage of time that the primary amperage level is commanded versus the background level.

(PPS) Pulses per Second -controls the frequency of pulses and is displayed as PPS Pulses per second. This adjusts the number of times per second the amperage is toggled between Primary and Background Amps. Figure 5 – Independent Pulse Waveform, illustrates the relationships between these four variables.

Sync to Oscillation

The second pulsed amperage method is achieved

by syncing the amperage to the Oscillation. When Sync to Oscillation is selected the only settings available to the operator are Primary Amps and Background Amps. All other parameters of this pulsing method are controlled by the Oscillator Parameters.

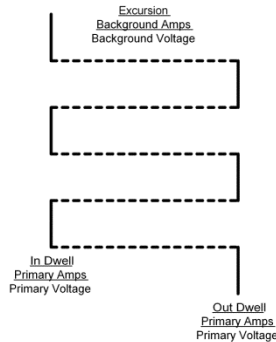

FIGURE 6 – SYNC TO OSCILLATION WAVEFORM

In Sync to Oscillation Mode, the Primary Amps are commanded while the oscillator is in either In Dwell or Out Dwell. Background Amps are commanded during the length of the Excursion Time which is set by the Excursion Speed (see Figure 6 - Sync to Oscillation Waveform). Shows the relationship of this type of pulse method.

ARC VOLTAGE CONTROL

MODES OF OPERATION

Arc Voltage Control has four modes of operation. They are: Sampled Continuous, Sampled Primary, Sampled Background, and Off. Depending on the customer's application the operator can configure the system to weld in any of these modes.

Sampled Continuous

In Sampled Continuous mode of operation, the AVC maintains the selected voltages during both the primary and background phases of welding.

Sampled Primary

In Sampled Primary mode of operation, the AVC maintains the selected voltage only during the primary phase of welding. During the background phase of operation no voltage corrections will be made.

Sampled Background

In Sampled Background mode of operation the AVC maintains the selected voltage only during the background phase of welding. During the primary

phase of operation no voltage corrections will be made.

NOTE



Sampled Background is not accessible when the AVC is welding in Non-Pulsed Applications.

AVC Off

In AVC Off mode of operation, the AVC will not adjust for voltage. This mode can be enabled or disabled at any time. This allows the ability to not react to specific conditions that may affect the welding operation.

VOLTAGE ADJUSTMENT CONTROLS

The AVC continually monitors all voltages and adjusts the voltage back into the parameters set by the operator. Deadband and Sensitivity set when and how quickly these adjustments occur.

Deadband

The Deadband parameter sets an acceptable window of error. This is useful in minimizing torch movement while welding rough material, when using Argon / Helium gas mixture, and during Pulsed Amperage applications to minimize overcorrecting during the transition from Primary to Background Amps and vice versa. This parameter is measured in voltage and provides the operator with up to a 1.5 voltage high and low window, or a 3 total volt window centered at the Primary or Background Voltage setting.

For example, while welding at 12 volts in a non-pulsed amperage application, if the Deadband is set to 1.5 volts, the AVC will not correct for any arc voltage within a range from 10.5 volts to 13.5 volts. Likewise, if the Deadband is set to .1 volts, the AVC will not correct for arc voltage within the range from 11.9 to 12.1 volts. Once the arc voltage goes below or above the selected range, the AVC will begin to correct for this error and will bring the arc voltage back into the window (see Figure 7 – Deadband Example).

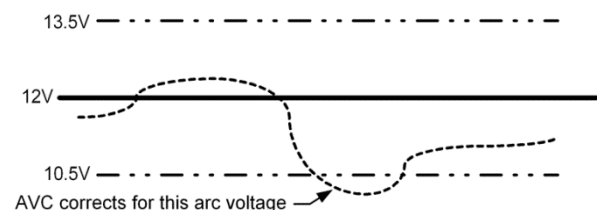

FIGURE 7 – DEADBAND EXAMPLE

Once the AVC brings the voltage back into the window, the torch will stop correcting. In the first example above, the AVC will stop the torch as soon as the arc voltage is within the window. It may not adjust the arc voltage to 12 volts when a 1.5 volt Deadband value is set.

Sensitivity

The Sensitivity parameter adjusts the speed of correction. This determines how fast the AVC moves the torch to get the arc voltage back into the Deadband window.

Sensitivity is a percentage parameter. Setting Sensitivity to 100% means that the maximum speed is used to get back into the Deadband window. Setting sensitivity to 0%, means that no adjustment will occur to correct for the arc voltage error.

A common range for Sensitivity is 25% to 45%.

WIRE FEED

Wire Feed settings allow the operator to adjust wire speed. There are two wire feed modes, Sync to Pulse and Continuous.

Primary Wire Speed controls the wire feed during dwell times in Sync Mode or in Continuous Mode.

When Sync to Pulse is selected the operator must set the Background Wire Speed as well as the Primary Wire Speed.

SYNC TO PULSE

Using Sync to Pulse delivers two different wire speeds during Independent Pulse Amperage Mode and Sync to Oscillation Amperage Mode. In Independent Pulse Amperage Mode the two speeds are Primary and Background Amperage Pulse waveform. In Sync to Oscillation Amperage Mode the two speeds are during Dwell and Excursion Times.

When two wire speeds are desired, Sync to Pulse makes the Wire Feed Settings easy to adjust and synchronize to the rest of the welding process and parameters; because the wire speed will be synced with the correct timing whether Amperage is set to Independent Pulse or Sync to Oscillation.

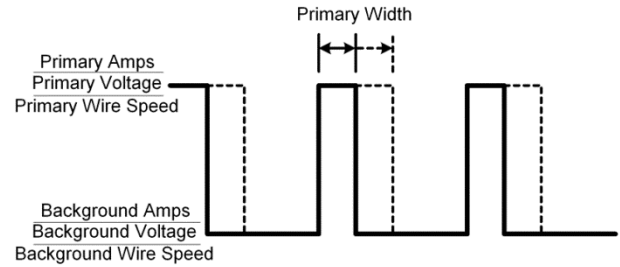

FIGURE 8 – WIRE FEED SYNC TO PULSE

PRIMARY WIRE SPEED

Primary wire speed is used to control the wire speed during either a non-pulsed application or to control the wire speed at the primary amperage portion of the pulsed waveform or during the In and Out Dwell Times of the Oscillation (see figure 8 – Wire Speed Sync to Pulse and Figure 9 - Wire Speed Sync to Oscillation Amps).

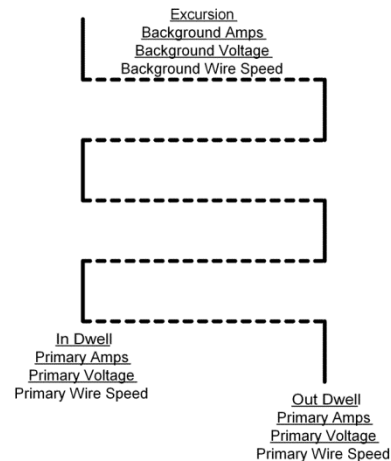

FIGURE 9 – WIRE SPEED SYNC TO OSCILLATION (AMPS)

BACKGROUND WIRE SPEED

Background Wire Speed is used to control the wire speed during the Background Amperage portion of the Pulsed Waveform or during the Excursion time of the Arc Oscillation (see Figure 8 – Wire Speed Sync to Pulse and Figure 9 – Wire Speed Sync to Oscillation Amps).

CONTINUOUS

In Continuous mode the wire speed is constant regardless of Primary or Background Amperage.

INSTALLATION

TECHNICAL SPECIFICATIONS

Mains Connection

Idle/Running	VOLTAGE 50-60 HZ	CURRENT DRAW
I	100 VAC	
R	100 VAC	
I	120 VAC	
R	120 VAC	
I	220 VAC	
R	220 VAC	

Fuse Type and Value

Fuse Function	Fuse	Type
Travel	1 A	Slow
W1	1 A	Slow
W2	1 A	Slow
AVC	1 A	Slow
OSC	1 A	Slow

Output amperage

Voltage Value	Amperage Output
Mains 100 V	
Mains 120 V	
Mains 220-240 V	

Temperature Ranges

Operating Range	Storage Range

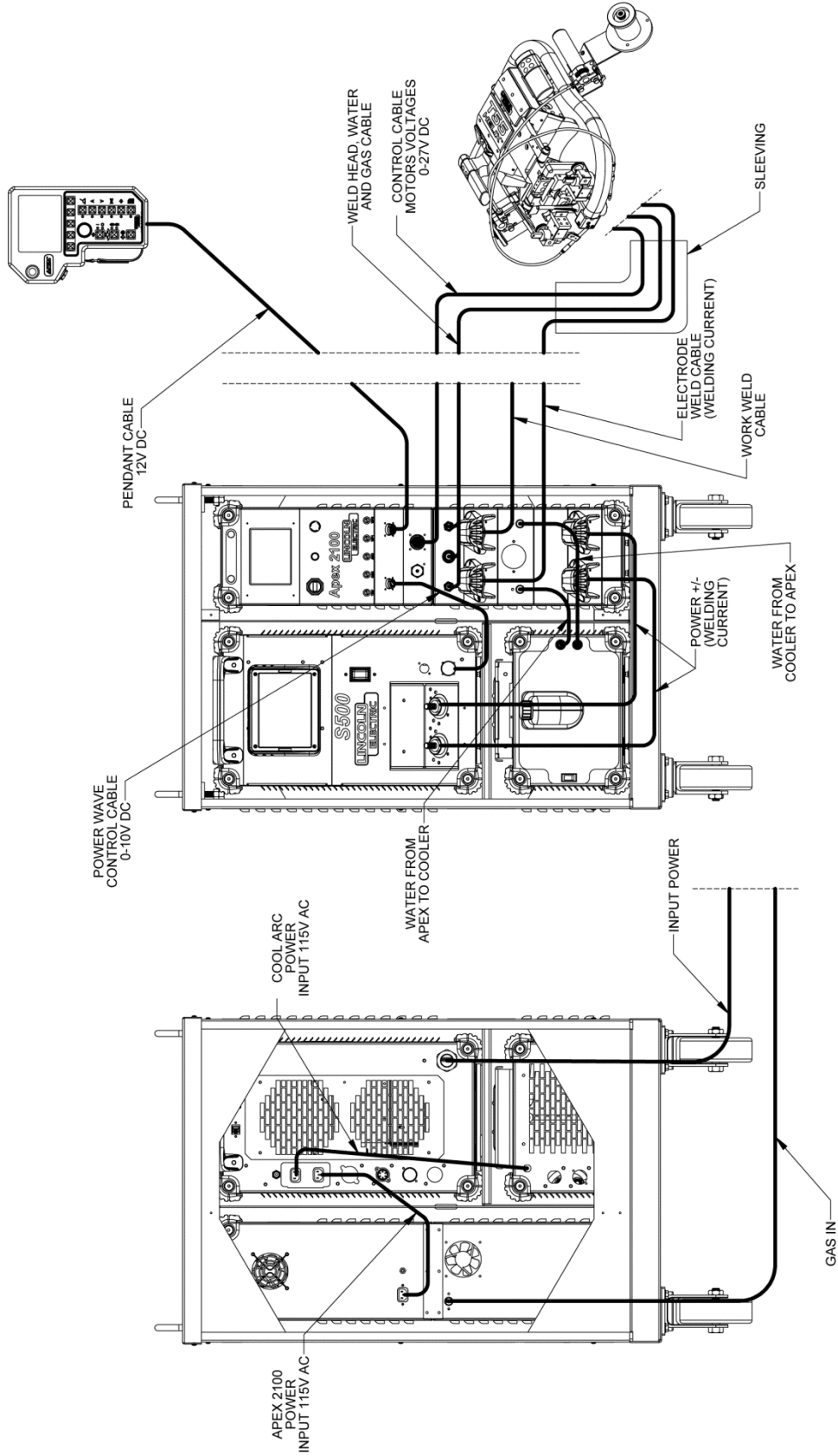

FIGURE 10 – CABLE MAP COMPLETE SYSTEM

Warning! Do not attempt to install cables with power applied to the unit. Ensure the unit is not attached to input power and all equipment is Off.

NOTE Verify that all systems are set up according to Instructions before powering up the unit.



TRACTOR INSTALLATION

Before operating the Orbital Control System, please ensure proper installation of tractor (see Helix T55 Operators Manual IM6112).

BASIC INFORMATION

The operator needs to ensure proper installation of all cables and equipment (see Figure 10 Cable Map Complete System). It is recommended that the system be kept on a level surface and that the wheels be blocked in place throughout the welding process and before beginning the installation process.

CABLE ASSEMBLIES

The Orbital Control System comes with cable assemblies connected between the cabinet equipment. All external cables will need to be attached before operation. These instructions will guide the operator through the set up process for all cables.

Refer to Figure 11 – Cable Map Front for locations of each step for the cable assembly process on the front of the control unit. Steps 1 & 2 are completed before shipping.

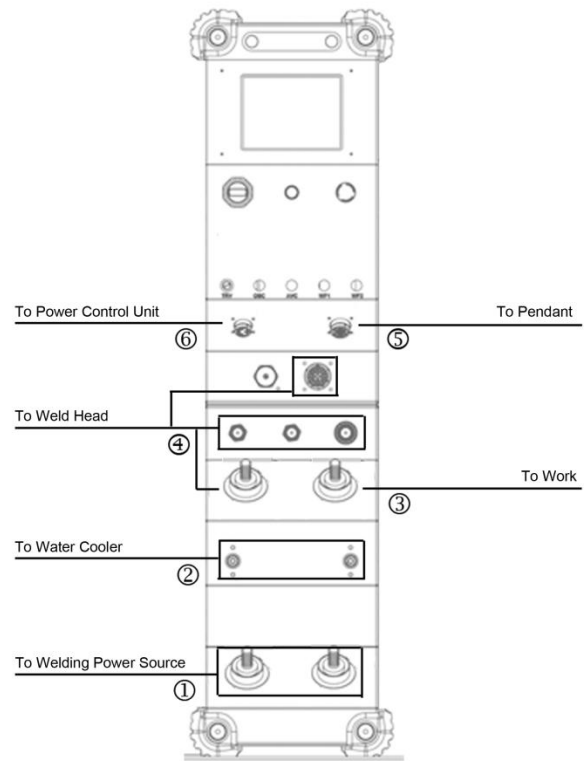

FIGURE 11 – CABLE MAP FRONT

Warning!!! Rubber Lead Covers are installed for safety and should never be touched when power is applied to unit.

1. Lift the protective rubber covers and using a $\frac{3}{4}$ inch wrench bolt the two 500 W Power Cables from the Control Unit Positive and Negative Leads to the Power Supply Leads.
 - a. Connect 35" Cable # S29194 from Negative to Negative.
 - b. Connect 36" Cable # S29195 from Positive to Positive
2. Using an 11/16 inch wrench, connect the Water Outlet Hose and Water Inlet Hose from the Control Unit to the Water Cooler Unit.
 - a. Attach Water Outlet Hose # S29190 to the left connector water outlet on the Control Unit, the Quick Disconnect end of the cable hooks into the top, Water Cooler Input.

- b. Attach Water Inlet Hose # S29189 to the right connector water outlet on the Control Unit, the Quick Disconnect end of the cable hooks into the bottom, Water Cooler Output.
3. Lift the protective rubber cover and bolt the Lug end of the Work Cable to the Lead on the Right side of the Control Unit.
4. Attach all Tractor Assembly cables to the Control Unit.
 - a. Lift the protective rubber cover and bolt the Electrode cable to the Left Lead on the Control Unit.
 - b. Connect Water Input and Water Output Quick Disconnect Hoses, Male to Female and vice versa.
 - c. Using an 11/16 inch wrench connect the gas line to the far right connector.
 - d. Connect the Control Cable to the Amphenol plug.
5. Connect the Pendant Cable from the Pendant to the Control Unit. The cable end with the protective white sheathing connects to the Pendant.
6. Connect the 27" Power Supply Command Cable from the Control Unit to the Power Supply.

Refer to Figure 12 for locations of each step for the cable assembly process on the back of the cabinet. Steps 7 & 8 are completed before shipping.

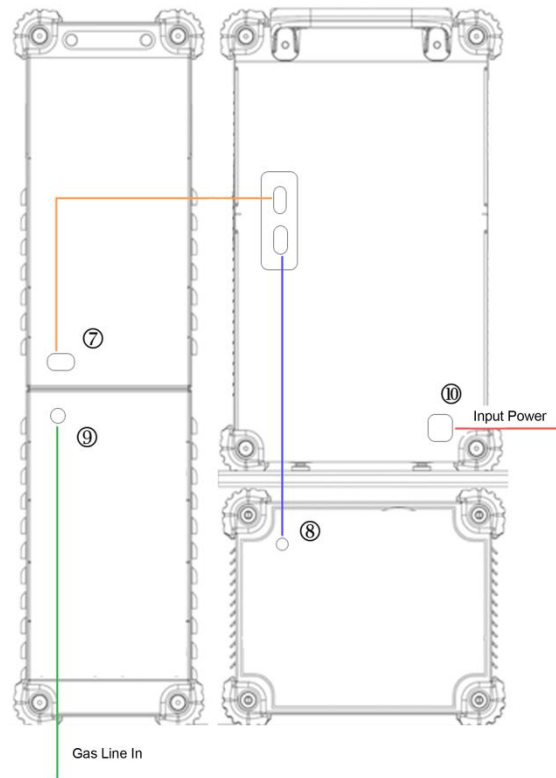

FIGURE 12 – CABLE MAP BACK

7. Connect the power cable from the back of the Control Unit to the supplied plug on the Power Supply.
8. Connect the Power Cable from the back of the Water Cooling Unit to the Power Supply.
9. Connect the Gas input to the back of the Control Unit.
10. Verify that all safety precautions have been followed and attach the Power Supply cable to appropriate Input Power. Refer to Power Wave S500 Operator's Manual IM10118.

OPERATION

GENERAL OPERATIONAL DESCRIPTION

The APEX 2100 Orbital Control System is a micro-processor-controlled system that automatically controls the processes of pre-purge, starting the arc, travel, wire, Arc Voltage Control (AVC) and Oscillation from start to ending the cycle.

The operational parameters required to run the welding process are entered through a small, convenient pendant assembly (see Figure 13 – Pendant).

PENDANT

The pendant has an LCD display and several buttons to quickly access all the parameters. In addition, an encoder allows the operator to easily adjust parameters.

Figure 13 – Pendant, shows the features of the pendant and illustrates the quick access to all weld parameters.

The Pendant can be broken into 5 sections:

- Display
- Navigation
- Selection
- Encoder
- Control

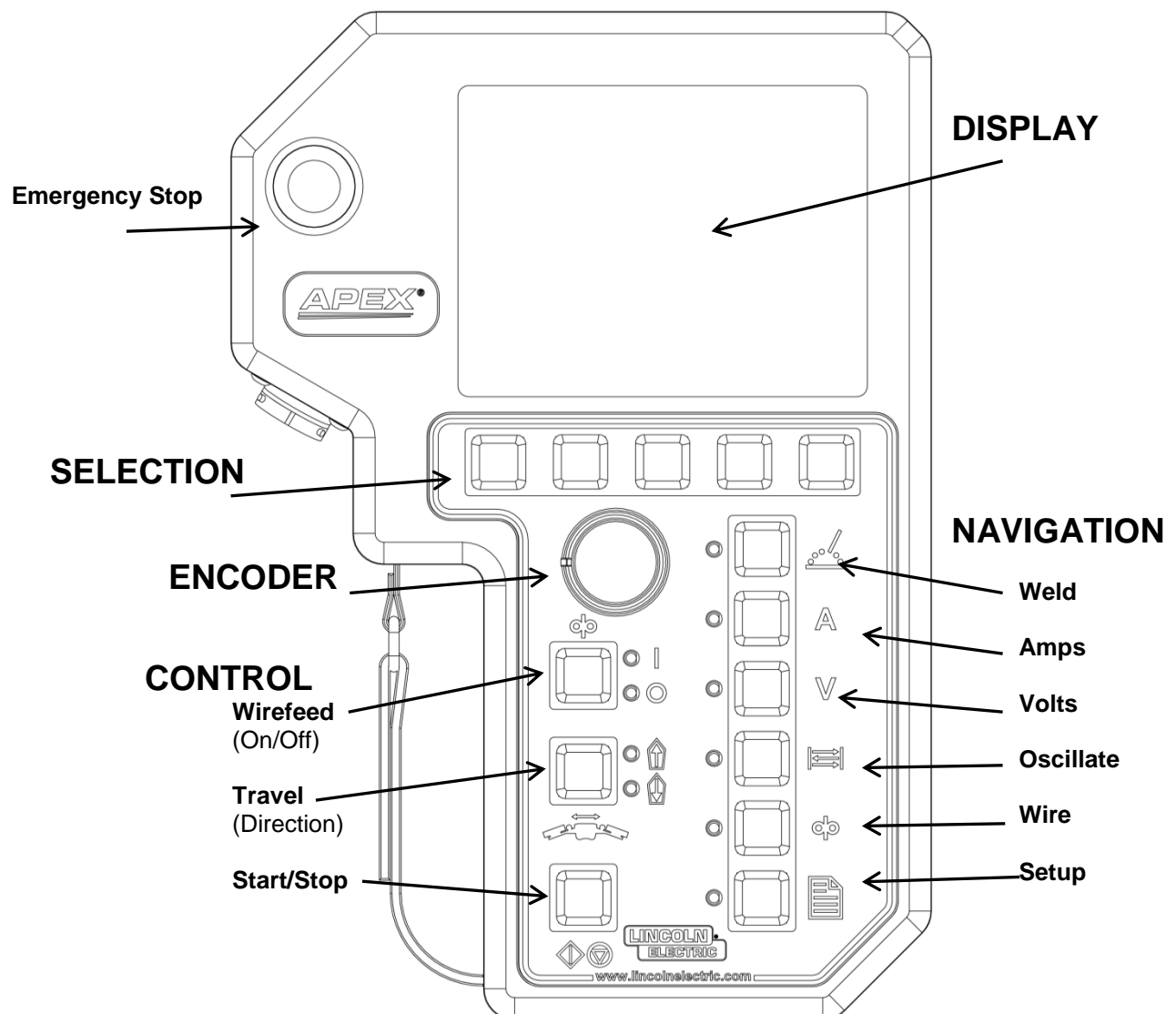

FIGURE 13 – PENDANT

Display

The Display Screen is an LCD Screen that shows the current menu selected by the User. This screen is mirrored on the Control Assembly.

Navigation

The Navigation Buttons enable the user to switch between menus on the pendant. The Navigation Buttons are Weld, Amp, Voltage, Oscillate, Wire & Setup. Pressing each button once brings up the selected menu on the display making it possible to change the parameters using the Encoder, and Selection Buttons.

Selection

The Selection Buttons are variable use buttons, whose purpose is determined by the menu options on the Display. Different words or images will be displayed directly above each of the 5 buttons. Pressing the button below the desired word or symbol will select the function for that word or symbol.

Encoder

The Encoder knob is used to adjust most welding parameters, clockwise rotation increases selected value and counter-clockwise rotation decreases the value. Height and oscillation control will be changed using the Encoder. Clockwise will increase height and oscillation or move the weld head out, counterclockwise rotation will decrease height and oscillation or move the weld head in towards the tractor.

Control

There are four control buttons and they are:

- Wire (On/Off)
- Travel (Direction)
- Start/Stop
- E-Stop

Selection Images

The selection buttons will display words, images or arrows which allow the operator to change or confirm the system settings

Images



Images will guide the operator through the screens, (selecting Amp, Volts, Wire, etc.) and will allow the selection of certain options, as illustrated by the images to the left. These images will

be displayed on the LCD screen just above the selection buttons on the Pendant. When the button below the image on the LCD is pressed the option above that button will be selected.



Arrows

Arrows appear on the screen in many of the pendant menus. These arrows are used to select between parameters being displayed on the LCD screen. Pressing the button beneath the Arrow on the

screen will move the cursor from one field or parameter to the next, where the Encoder can be used to change the value.

Power on Initial Screen

When the Control System is powered on, the pendant LCD display will present a login screen (see Figure 14 – Initial Power Screen). Adjust the Encoder to cycle through the letters and numbers. Once the correct character is displayed Press the Next Selection button, the cursor will advance to the next character. When the entire code is entered, press the Enter Button to gain access to the system.

The default code is 1123.

NOTE

If an incorrect code is entered the system requires power to be cycled before entering a new code.

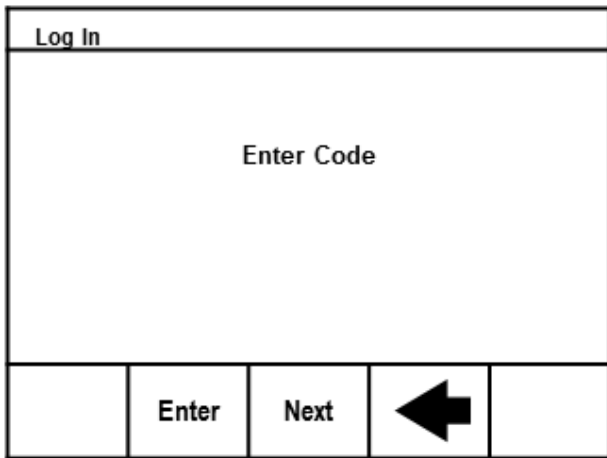

FIGURE 14 – INITIAL POWER SCREEN

Program Selection Screen

Once granted access to the controller the first screen presented to the operator is the Program Selection Screen (see Figure 15 – Program Selection).

From this screen the operator can load new programs and access saved programs. This screen also allows access to Calibration, Tools, and Menu Screens.

All Program Menus and their functions are discussed later in the manual in the Program Screens section.

NOTE



By default, changes made to the system are automatically saved so that when power is cycled the system will return to the same state. These changes are saved when changing menu screens or when starting the weld cycle.

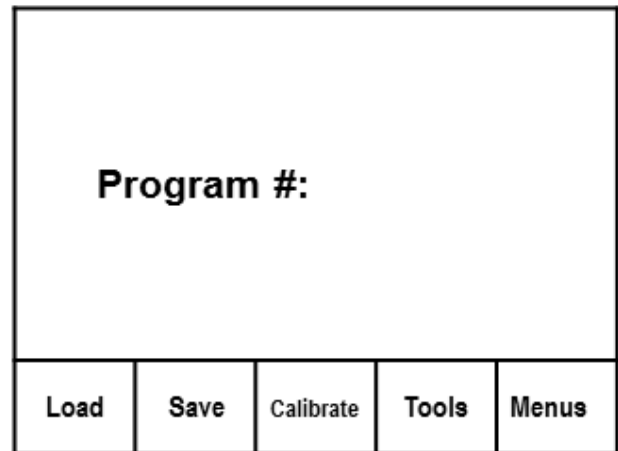

FIGURE 15 – PROGRAM SELECTION SCREEN

BEGIN WELDING

To begin welding using the current program; welding and setup parameters, press the Weld button at the top of the Navigation Buttons on the Pendant (see Figure 13 – Pendant on page 12).

JOG MENU

Pressing the Weld Button brings up the Jog Menu (see Figure 16 –Jog Menu Screen Wire). This screen allows the operator to make adjustments to or verify five different functions:

- Wire Speed
- Travel Speed (Selectable)
- Direction
- Torch Height
- Gas

The Wire and Travel Selection Buttons each bring up a separate menu (see Figure 16 – Jog Menu Screen Wire and Figure 18 Jog Menu Screen Travel). DIR, Torch Height and GAS can be engaged from either menu.

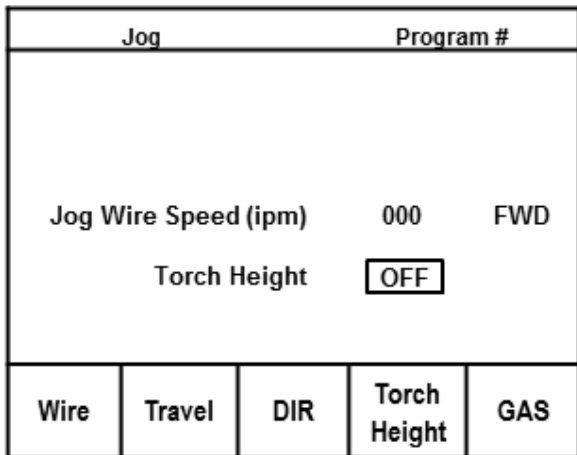

FIGURE 16 – JOG MENU SCREEN WIRE

Jog Menu Items

To make adjustments to any of the Jog Menu options, press the selection button under Wire or Travel to bring up the individual menu. The DIR, Torch Height and Gas options can be activated in either screen. Adjustments can be made with the Encoder.

NOTE



When changing from Wire to Travel or Torch Height, or any combination of these, the speed is always reset to zero, no matter what was selected in the previous menu.

Wire

The Jog Menu Screen for wire is the default menu that appears when the Weld Button is pressed (see Figure 16- Jog Menu Screen Wire). Pressing the Wire Selection Button will toggle between the Jog Wire Speed and Torch Height. Adjust the Jog Wire Speed value using the Encoder.

To switch between the Primary and Secondary Wire Press the Control Button labeled Travel (see Figure 17 – Travel Button). The Fwd light will be illuminated for Wire 1 and the Rev light will be illuminated for Wire 2.

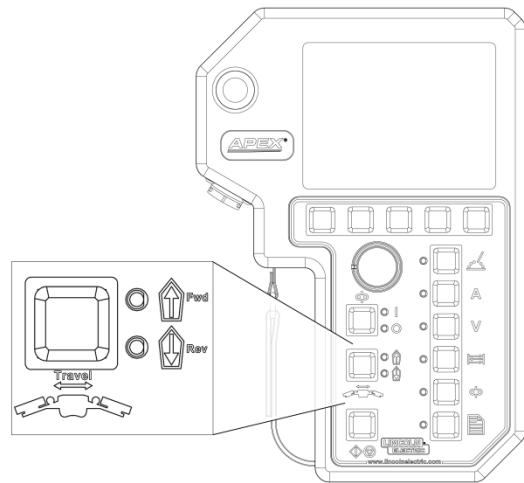

FIGURE 17 – TRAVEL BUTTON

NOTE



Cut wire cleanly to prevent binding when retracting wire.

Travel

The Jog Menu Screen for Travel is accessed by pressing the Travel Selection Button. Press the Travel Selection Button again to highlight the value. Pressing the Travel Selection Button will select between Jog Travel Speed and Torch Height.

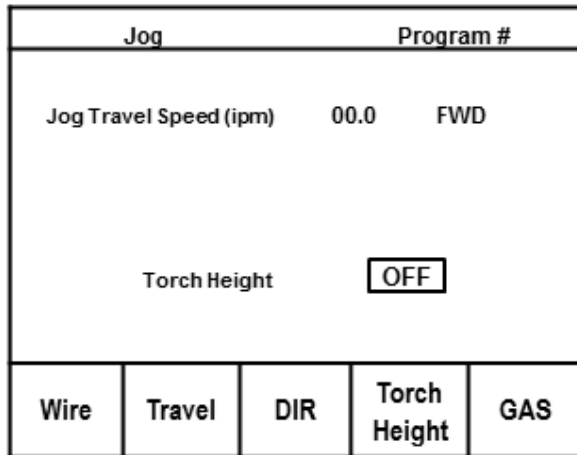

FIGURE 18 – JOG MENU SCREEN TRAVEL

NOTE



Verify that the weld head is secure and free from obstructions before adjusting travel speed.

Adjust the Encoder clockwise to increase the weld head speed and counter clockwise to decrease speed. To change direction press the DIR Selection Button or the Travel Control Button.

Pressing the Back Selection Button will halt travel and return the user to the Jog Wire Speed Menu.

DIR

The Direction Selection Button (DIR) switches between forward and reverse movement for the Wire and Weld Head Travel. To reverse the travel direction, press the DIR button, the weld head will reverse direction at the same speed.

NOTE



Changing direction of speed while tractor is at full speed will run the risk of blowing the travel motor fuse.

Torch Height

Pressing the Torch Height Selection Button will toggle the Torch Height Button On and Off. Adjust the torch height using the Encoder; clockwise for will increase torch height, counterclockwise will decrease torch height.

Gas

Pressing the Gas Selection Button will activate the gas solenoid for 8 seconds, allowing the operator to verify the proper flow rate and adjust as necessary.

Pressing the Gas Selection button a second time during the 8 seconds will keep gas on until the gas button is pressed a 3rd time.

NOTE



Shielding Gas is also purged when the control unit is powered on. This allows the lines to be purged automatically, which is useful if the unit has been off for a long period of time. The gas will be purged for 8 seconds

WELD SCREEN

Once the Torch Height, Weld Head and Wire are positioned to the operator's satisfaction, press the Weld Button once more to bring up the Weld Screen (see Figure 19 – Weld Screen). Pressing the Weld Navigation Button will toggle between Weld Screen and Jog Menu.

The Weld Screen allows the operator to adjust the values for:

- Amps
- Voltage
- Wire
- Travel
- Center/Width

Setting Mode		Program #		
220				
Primary Amps				
220	12.4	118	22.1	0.0
Amps	Voltage	Wire	Travel	Center Width
140	12.4	118	Weld	0.0

FIGURE 19 – WELD SCREEN

AMPS, Voltage & Wire Functions

Primary and Background

Amps, Voltage, and Wire, all have Primary and Background Values. To select between the Primary and Background Values press the Selection Button below the desired function. Pressing the Selection Button below Amps will change from the Primary Amps to Background Amps (see Figure 19 -Weld Screen and Figure 20 - Weld Screen Background).

The same process used to change between Primary and Background Amps is used to change between Primary and Background values for Voltage and Wire.

The selected value will appear at the top of the screen.

Setting Mode		Program #		
140				
Background Amps				
220	12.4	118	22.1	0.0
Amps	Voltage	Wire	Travel	Center Width
140	12.4	118	Test	0.0

FIGURE 20 – WELD SCREEN BACKGROUND

The Amps, Voltage, and Wire values can be adjusted while welding or not. While welding, adjusting the Encoder will change the selected output or speed, as well as changing the value on the screen. When not welding, only the value on the screen will change.

Travel Functions

The Travel Speed can be selected in the same manner as the Amps, Voltage and Wire. Travel Speed can also be adjusted while welding or not. While welding, adjusting the Encoder will change the speed of the tractor, as well as the value on the screen. When not welding, only the value on the screen will change.

Center/Width Functions (Oscillator)

Pressing the Selection Button below Center/Width will select between Center and Width Adjustment values. A box will appear around the Selected Value and the value will also appear in the center of the screen.

Center Position

The Center Position can be adjusted at any time during the weld or while preparing to weld. When the system is not oscillating the arc, the Center Position acts as steering to adjust the torch position.

Width Adjustment

While oscillating the arc, the width adjustment controls how wide to make the bead. Adjusting this when the torch is not oscillating will only change the value displayed on the screen. While welding, the bead narrows or widens as the Encoder is adjusted.

See Figure 3 – Center/Width Interaction, on page 4 for more information.

WELD / TEST FUNCTION

The system can be configured to either Weld or Test weld. In Weld configuration when the Start / Stop button is enabled the system will start the standard welding sequence and proceed to weld. When in Test Weld configuration, the system will simulate welding to allow verification of setup and operation of the system.

To cycle between Weld and Test Weld, select the button below the Travel section until Weld or Test is highlighted. Pressing the button again will toggle between Weld and Test Weld.

AMPS SCREEN

Pressing the Amps Navigation button will bring up the Amps Screen which is used to select between three modes of operation:

- Pulsed Arc
- No Pulse
- Sync Pulse

The selected mode will be displayed at the bottom of the screen. To switch between the 3 modes choose the appropriate selection button (see Figures 21-25).

Pulsed Arc

Once Pulsed Arc has been selected adjustments can be made to Primary Amps, Background Amps Primary Width and Pulses Per Second (PPS). To switch between each value use the Arrow down Selection button (see Figure 21 – Amps Screen Pulsed Arc).

Welding Amperage		Program #	
Primary Amps	200	Primary Width	50 %
Background Amps	100	PPS	01.0
Pulsed Arc			
No Pulse		Sync Pulse	Const Travel
			

FIGURE 21 – AMPS SCREEN PULSED ARC

In both Pulsed Arc and Sync Pulse modes Step Travel can be toggled on or off using the Selection Buttons.

Travel

There are two modes of Travel. Step Travel and Constant (Const Travel). Pressing the selection button beneath the Const Travel (see Figure 21- Amps Screen Pulsed Arc), will toggle travel to Step travel (See Figure 22 – Amps Screen Pulsed Arc Step Travel).

Step travel ties the tractor's movement into the Background Amps, which will only allow the tractor to move while in Background Amperage.

Welding Amperage		Program #	
Primary Amps	200	Primary Width	50 %
Background Amps	100	PPS	01.0
Pulsed Arc			
No Pulse		Sync Pulse	Step Travel
↓			

FIGURE 22 -- AMPS SCREEN PULSED ARC STEP TRAVEL

In Const Travel the tractor will move at the pre set speed regardless of background amperage (see Figure 23 - Travel Examples).

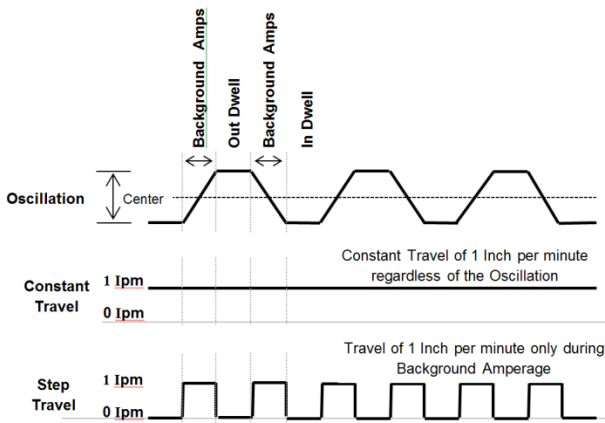

FIGURE 23 – TRAVEL EXAMPLES

Sync Pulse

In Sync to Pulse mode, the amperage is tied to the Oscillation Motion. From this menu adjustments can be made to the Primary and Background Amps.

To select between each value use the Arrow down Selection button (see Figure 24 – Amps Screen Sync Pulse).

Primary Amps sets the amperage from the power source during the time the oscillator is in either In Dwell or Out Dwell time periods. In this menu, Primary Amps are generally set higher than Background Amps to allow good sidewall penetration.

Welding Amperage		Program #	
Primary Amps	200		
Background Amps	100		
Sync Pulse			
No Pulse	Pulsed Arc		Const Travel
↓			

FIGURE 24 – AMPS SCREEN SYNC PULSE

Background Amps sets the time the Oscillator transitions from the In and Out Dwell Times, moving the torch from the In to Out positions of the Oscillator and determines the amperage value commanded from the welding power source during this excursion time.

No Pulse

With Amperage set for No Pulse or Continuous Current, only the Primary Amps Value can be adjusted (see Figure 25 –Amps Screen No Pulse).

Welding Amperage		Program #	
Primary Amps	200		
Continuous Current – No Pulse			
	Pulsed Arc	Sync Pulse	

FIGURE 25 – AMPS SCREEN NO PULSE

VOLTAGE SCREEN

Voltage Modes

Pressing the Volts Navigation button will bring up the Voltage Screen.

There are four modes of AVC voltage operation, providing maximum flexibility of arc voltage control of the welding arc. The four modes are:

- Sampled Continuous
- Sampled Primary
- Sampled Background
- AVC On/Off

The operator can change between modes by pressing the Selection button below the desired mode.

Sampled Continuous

In Sampled Continuous mode of operation, the operator has control of both primary and background voltages, as well as Deadband and Sensitivity (see Figure 26 – Volts Screen Sampled Continuous).

Arc Voltage		Program #	
Primary Voltage	10.0	Deadband	0.8
Bkgr. Voltage	08.5	Sensitivity	035
Sampled Continuous (ON)			
AVC On/Off	Sampled Primary	Sampled Bkgr.	↓

FIGURE 26 – VOLTAGE SCREEN SAMPLED CONTINUOUS

This mode of operation is the most sophisticated, requiring the operator to set both primary and background voltages to adjust the arc voltage smoothly from primary to background voltage without excessive AVC overcorrection.

Sampled Primary

In Sampled Primary mode, the operator has control of the Primary Voltage, Deadband and Sensitivity.

There is no background voltage to adjust in Sampled Primary. The controller will lock out the AVC drive mechanism from moving or correcting for arc voltage during the Background Amperage Pulse when in Pulsed Arc mode. The controller will also lock out the AVC during Excursion time, when Amperage is set to Sync to Oscillation (see Figure 27 – Volts Screen, Sampled Primary).

Arc Voltage		Program #	
Primary Voltage	10.0	Deadband	0.8
		Sensitivity	035
Sampled Primary (ON)			
AVC On/Off		Sampled Bkgr.	Sampled Cont. ↓

FIGURE 27 – VOLTAGE SCREEN SAMPLED PRIMARY

Sampled Background

In Sampled Background mode, the operator has control of Background Voltage, Deadband and Sensitivity (see figure 28 - Volts Screen Sampled Background).

Arc Voltage		Program #	
		Deadband	0.8
Bkgr. Voltage	08.5	Sensitivity	035
Sampled Background (ON)			
AVC On/Off	Sampled Primary		Sampled Cont. ↓

FIGURE 28 – VOLTAGE SCREEN SAMPLED BACKGROUND

AVC On/Off

The AVC can be engaged or disengaged by pressing the Selection button below the AVC On/Off.

When turned off, the AVC will not track for any voltage errors. Selecting On/Off will turn Voltage on or off for all modes of operation. A status and confirmation message will appear on the screen just above the text, e.g. Sampled Primary On or Sampled Primary OFF.

NOTE

Only AVC On/Off mode can be changed while welding.

**Voltage Parameters**

The Volts Screen has all settings needed to control the Voltage parameters of the welding arc and of the Arc Voltage Control incorporated in the controller. When first selected, the Volts screen displays the parameters:

- Primary Voltage
- Background Voltage
- Deadband
- Sensitivity

Of these four values, the default highlighted value is Primary Voltage, where available (see Figure 26 Voltage Screen Sampled Continuous).

Primary voltage

Primary voltage is used to control the arc voltage during the primary amperage pulse (during the Primary pulse width time) when pulsing in Pulsed arc mode or during the Dwell Time when Amperage Sync to Oscillation is selected.

NOTE

Primary Voltage can also be considered Dwell Voltage when Amperage is set to Sync to Oscillation.

**Background Voltage**

Background Voltage is used to control the arc voltage during the background amperage pulse, when in Pulsed Arc mode; or during the Excursion Time, when Amperage is set to Sync to Oscillation.

NOTE

Background voltage can also be considered Excursion Voltage when Amperage is in Sync to Oscillation.

**Deadband**

Deadband creates an acceptable window of deviation voltage centered at either the Primary or Background Voltage; where if the arc voltage is within this acceptable window, the AVC system incorporated in the controller will not track / make adjustments to the arc voltage. See Deadband in the Basic Information Section on page 7.

Deadband can create value of .2 volts to 3.0 volt window (± 1 volts to ± 1.5 volts from either the selected Primary or Background Voltage).

Sensitivity

Sensitivity works in conjunction with Deadband to allow for smoother corrections of arc voltage, minimizing the AVC drive mechanism from constantly overcorrecting. See Sensitivity in the "Description of Equipment" section. See Sensitivity in the Basic Information Section on page 7.

This parameter is a percentage of the maximum speed of the AVC drive mechanism and can range from 0 to 100 percent. Visible motion may not be noticed until 20 to 35 depending on motor.

OSCILLATOR SCREEN

Pressing the Osc. Navigation button will bring up the Oscillator Screen. This menu displays five options available to the operator:

- Center Position
- Oscillation Width
- In Dwell
- Excursion Time
- Out Dwell

Osc. Test and Osc On/Off can be activated with the Selection buttons (see Figure 29 – Oscillator Screen).



Mechanical Oscillator	Program #	
Center Position	0.00	in.
Oscillation Width	0.05	in.
In Dwell	00.5	sec
Excursion Time	00.1	sec
Out Dwell	00.5	sec
Oscillation (ON)		
Osc. Test OFF	Osc. On/Off	 

FIGURE 29 – OSCILLATOR SCREEN

For more information about the Oscillator, please review the Basic Information section on page 5.

Osc. Test

Osc. Test allows the user to verify settings and to observe the weld head oscillation. Press the Osc. Test Selection Button and the weld head will begin to oscillate at the settings entered on the screen.

NOTE



Before testing oscillator, verify that there is sufficient space to allow the oscillation's width movement (1").

When testing is completed, press the Osc. Test Selection button to turn the oscillation Off and be driven to the center position.

Osc. On/Off

Oscillation is an optional function. To select whether or not the weld head will oscillate during welding, press the Osc. On/Off Selection Button. Turning on Oscillation will display the "Oscillation (ON)" at the bottom center of the screen.

There are five parameters that can be set for Oscillation.

Center Position

Sets the center point of the weld head. This value is measured in inches and goes +/- 0.50 for a total of 1.0 inches. 0 sets the weld head at the very center.

Oscillation Width

Determines how wide the torch head will travel during oscillation. This goes from 0 to 1.0 inch.

In Dwell

The In Dwell represents the time the weld head oscillator and torch will stay toward the weld head carriage, measured in seconds from 0 to 99.9.

Excursion Time

Excursion Time determines the transition time between in and out dwell times, it is measured in seconds from 0.1 to 4 seconds.

Out Dwell

Out Dwell time represents the time the weld head oscillator and torch stay out away from the weld head carriage, measured in seconds from 0 to 99.9.

WIRE SCREEN

Selecting the Wire Navigation button will bring up the Wire Screen which allows the operator to choose between two modes, Sync. To Pulse, and Continuous. Pressing the Sync. On/Off button will switch between these two modes. Wire 2 is an optional wire feeder which can be enabled or disabled from this menu by pressing the Wire 2 ON Selection Button.

Wire Feed		Program #		
Primary Wire Speed	045	ipm		
Bkgr. Wire Speed	000	ipm		
Sync. to Pulse				
Wire 2 ON		Sync. On/Off		↓

FIGURE 30 – WIRE SCREEN SYNC TO PULSE

Sync to Pulse

Sync. to Pulse ties the Wire Speed to the Amperage Pulse.

While in Sync to Pulse, there are two adjustable parameters to control the wire speed during welding: Primary Wire Speed and Background Wire Speed (Bkgr. Wire Speed). Both of these values are measured in Inches per minute (ipm) (see figure 30 Wire Screen Sync to Pulse).

Primary Wire Speed

This value determines the wire speed during Primary Amperage mode. Paired with Background Wire Speed these values will insure a consistent amount of wire is fed to the weld for smooth welding applications.

Background Wire Speed

This value determines the wire speed during Background Amperage.

NOTE



The Primary and Background Wire Speeds can also be considered Dwell and Excursion Wire Speeds when Sync to Pulse and the Amperage is set to Sync to Oscillation.

To change the Wire speed mode of operation and sync the wire speed to pulsed amperage, press the button below Sync On/Off.

Continuous

Continuous sets the Wire Speed at a constant rate of feed regardless of Primary or Background Amperage (see Figure 31 – Wire Screen Continuous).

Wire Feed		Program #		
Wire Feed Speed	045	ipm		
Continuous				
Wire 2 ON		Sync. On/Off		

FIGURE 31 – WIRE SCREEN CONTINUOUS

Wire 2

When the weld head is equipped with two wire feed motors, one for each direction, the second wire needs to be enabled. To enable the Wire feeder 2 on the controller, Press the Wire 2 Selection Button. Pressing the Wire 2 ON Selection Button multiple times will toggle Wire 2 On and Off.

NOTE



If the weld head has only one wire feed motor installed and the Wire 2 is enabled, there will not be any wire fed in the reverse direction of travel.

NOTE



If the weld head has 2 wire feed motors installed and the Wire 2 is disabled, the controller will feed wire from wire feeder 1 in both directions.

SETUP SCREEN

The Setup Screen is the first screen displayed after the operator logs onto the system (see Figure 32-Setup Screen). It is also accessed by pressing the Setup Navigation Button. The Setup Screens are useful in saving programs to internal memory or to a USB Flash Drive. In addition, programs from internal memory or from a USB Flash Drive can be loaded for use in the controller for current welding parameters or for future program needs. Calibration functions are accessed from this Setup menu screen. Calibration routines are not covered in this Section (see the Maintenance Section page 33). The remaining two menus available are Tools and Menu buttons.

The Setup Screen allows the Operator to access the following menus:

- Load
- Save
- Calibrate
- Tools
- Menu

All menus will return the operator to the Setup Default Screen by pressing the Back Selection button.

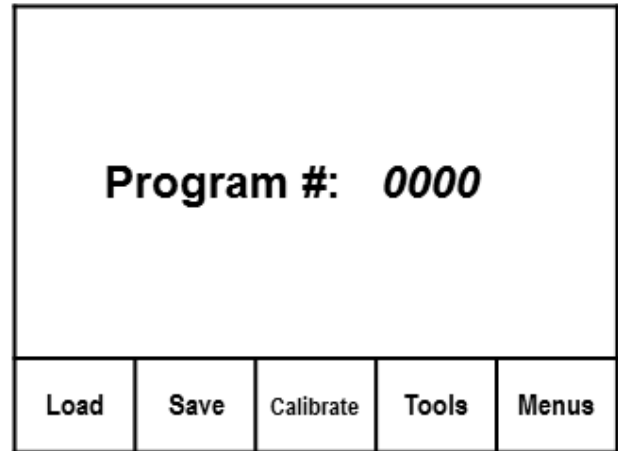

FIGURE 33 – SETUP SCREEN

Refer to Figure 33 for a quick flow chart of the Setup Screen options.



SETUP MENU SCREEN  Presents 5 selectable Options	Selectable Options									
	LOAD	→	Internal Eprom	External Flash						
	SAVE	→	Save	Delete	Scroll	Name				
	CALIBRATE	→	Speed Cal	OSC Check						
	TOOLS	→	Codes							
	MENU									
 Menu leads to 8 Sub Menus	Sub Menu open up to these options									
	Start of Weld	→	Pre Flow	Tungsten Preheat	Start Amp	Start Gap	Upslope time	AVC Start Delay	Travel Delay	Wire Delay
	End of Weld	→	Down Slope Time	Final Amps	Wire Stop Delay	Wire Retract	Torch Retract	Post Flow		
	Access Control	→	Return to Weld Screen	User Limits	Amps Menu	Volts Menu	Oscillation Menu	Wire Menu	Start of Weld Menu	End of Weld Menu
	Firmware Revision	→	LCD Controller	Pendent Controller	AVC/Oscillator Controller	CPU Controller Processor A	CPU Controller Processor B			
	Fault Monitoring	→	GAS	Water	Amps	Volts				
	Override Settings	→	Amps	Volts	Wire	Travel	Osc. Width			
	Increments	→	Amperage	Voltage	Wire Feed	Travel				
System Health	→	Pendant Controller	Wire Travel Controller	AVC/Oscillator Controller	CPU Controller Processor A	CPU Controller Processor B				

FIGURE 32 – SETUP SCREEN OPTIONS

Load

The Load Selection Button takes the operator to the Save Parameters Data screen (see Figure 34 – Save Parameters Data), which allows the operator to load saved programs from internal memory (Internal EPROM) or External Flash Drive (USB).

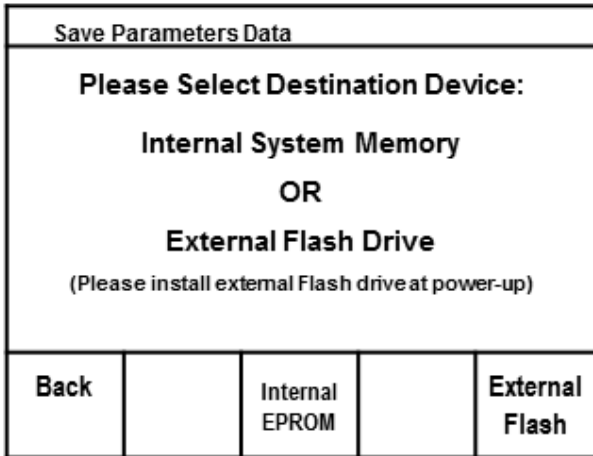

FIGURE 34 – SAVE PARAMETERS DATA

Pressing the Internal EPROM or External Flash Selections buttons will bring up the Scroll Programs screen which will allow the operator to select all available saved programs (see Figure 35 Load Screen Scroll Programs). Using the Encoder the operator can scroll through all available programs. Once the correct program is highlighted pressing the Select Selection Buttons will load the program parameters and take the user to the Weld Screen.

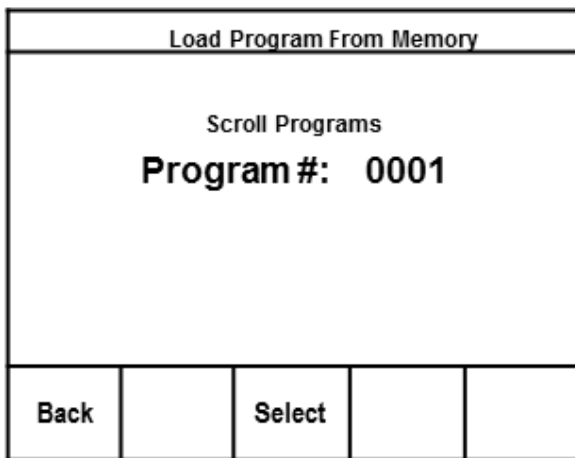

FIGURE 35 – LOAD SCREEN SCROLL PROGRAMS

Program 0001 is the default startup, it is not a valid selectable program. Once the operator has chosen values, those values can be designated as Program 0001 though the Save Screen.

Save Screen

From the Setup Screen pressing the Save Selection Button brings up the Save to Memory Screen (see Figure 36 – Save Screen), which allows the operator to save a program to internal or external memory, there are 5 selections buttons to choose from Back, Save, Delete, Scroll, and Name.

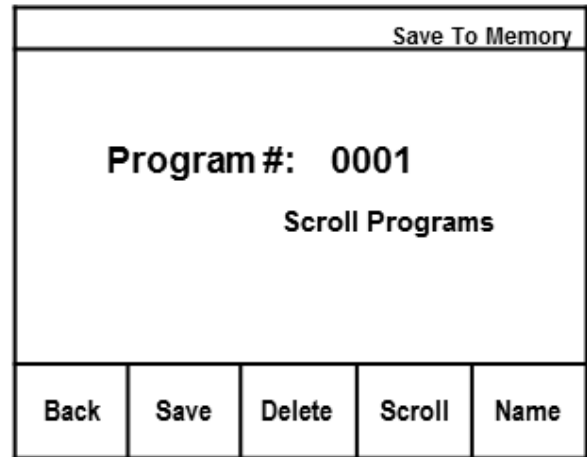

FIGURE 36 – SAVE SCREEN

Save

Pressing the Save Selection Button allows the operator to save to either internal or external memory and brings up the Save Parameters Data screen (figure 34). Save will use current parameters and store them as the Program # that appears on the screen.

For Figure 36, pressing the Save Selection Button will save the current parameters as Program 0001. If the name is already saved there will be a warning message:

“Program Name already Exist!
Overwire Existing Program?”

At this point the operator can either press Yes to overwrite or press the Back Button.

Delete

Delete will allow the operator to delete a saved program.

Pressing the Delete Selection Button will

delete whatever Program Number is on the screen. The operator will see a warning message:

“This Will Delete Selected Program! Permanently Delete Program?”

At this point the operator can either press Yes to delete the program or press the Back Button.

Scroll

Scroll allows the operator to choose between saved programs using the Encoder. Once a program is selected the operator can delete or name the program.

Name

Name will allow the operator to Program current selections with any available program name. Valid names are between 0001 and 9999. The Operator must press the Save Selection Button for settings to be saved.

Calibrate

The Calibration Screen (see Figure 37 – Calibration Screen) allows for two types of calibration. Oscillator Calibration and Speed Calibration.

NOTE



Oscillation Calibration is only required after significant weight or motor changes. Complete Software Calibration procedure is covered in the Maintenance section.

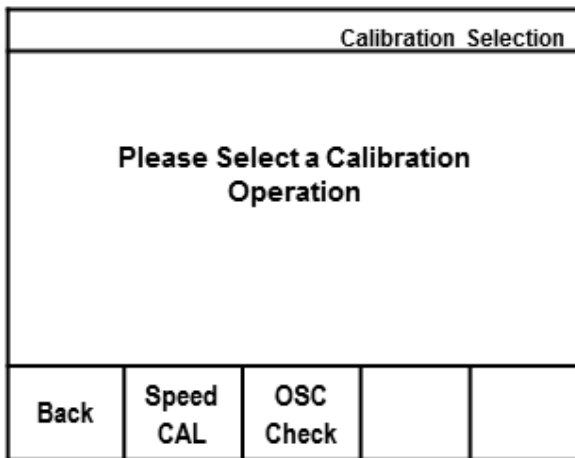

FIGURE 37 – CALIBRATION SCREEN

Speed CAL

This screen allows the operator to set the calibration speeds for all the software calibrations. All speeds should be set to the minimum speeds that will still allow movement without hesitation

OSC (Oscillator) Check

The Oscillator check measures the voltage necessary for oscillator to travel a specific length. This procedure will automatically populate the Oscillator Speed Value and determine the length of oscillation.

Tools

The Tools Menu (see Figure 38 – Tools) grants access to the Codes Menu (see Figure 39 – Codes Library).

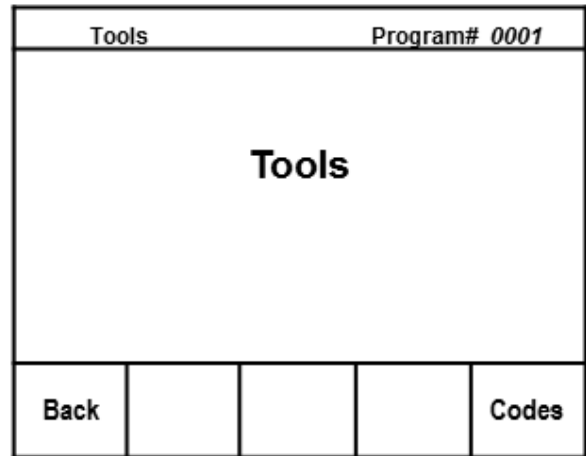

FIGURE 38 – TOOLS

Codes

Codes allow a supervisor to set up access codes for operators to use when running the equipment.

Use the Down Arrow to select the value to change. A box will surround the current Value.

Assign User # using the Encoder. Valid User Numbers are 1 through 25.

User's Code is a numeric code from 0000 to 9999.

User's Access Level is changed by pressing the Set Level Selection button. Options are User and Supervisor (Super).

Press the Save Selection button to Save Settings to the system .

Codes Library		Program# 0001	
User #:	<input type="text" value="01"/>		
User's Code:	0000		
User's Access Level:	User		
Back	Save	Set Level	

FIGURE 39 – CODES LIBRARY

MENUS SCREEN

The Menu screen gives the operator access to the following Options:

- Start of Weld
- End of Weld
- Access Control
- Firmware Rev.
- Fault Monitoring
- Override Settings
- Increments
- System Health



Edit	Program #		
Menu:			
Start Of Weld	Fault Monitoring		
End of Weld	Override Settings		
Access Control	Increments		
Firmware Rev.	System Health		
Back	Select		

FIGURE 40 – MENUS SCREEN

To navigate the Menu Screen, (see Figure 40 – Menu Screen), press the Arrow Selection Button to switch between the selections until the desired item is highlighted. Once highlighted, press the Select Selection Button to go into the desired screen.

The eight menu options with the exception of Firmware Rev. and System Health open up into sub menus with selectable options. These Sub Menu will be covered in detail beginning with Start of Weld Menu.

Start of Weld Menu

The Start of Weld Menu allows the Operator to adjust the parameters required to start the welding process and form an appropriate weld puddle (see Figure 41 - Start of Weld Parameters Screen).

For a complete timeline of the welding process, please review Figure 2 Orbital Process Time Line in the Description of Equipment Section Page 3.

The parameters on this menu are:

- Pre-Flow
- Tungsten preheat
- Start Amps
- Start Gap
- Upslope Time
- AVC Start Delay
- Travel Delay
- Wire Delay



Start of Weld		Program# 0001
Pre flow:	00.0	sec
Tungsten preheat:	00.0	sec
Start Amps:	00.0	Amps
Start Gap:	00.0	sec
Upslope Time:	00.0	sec
AVC Start Delay:	00.0	sec
Travel Delay:	00.0	sec
Wire Delay:	00.0	sec
Back		 

FIGURE 41 – START OF WELD

Pre-Flow

Pre-Flow is the amount of time Gas is to be purged before the arc is started to ensure adequate gas coverage is provided at the arc. This is measured in seconds and can go up to 99.9 seconds.

Tungsten Preheat

Tungsten Preheat is a time setting used to allow adequate preheating of the tungsten in order to strike an arc reliably each time without using High Frequency. This time is measured in seconds and can be as high as 99.9 seconds.

Start Amps

This value is commanded during tungsten preheat. The controller commands an amperage from the power source, this amperage is adjustable from 0 to 500 Amps. Start amps is ramped to the Primary Amps value through the Upslope Time Function.

Start Gap

Start Gap is a time function used to lift the torch upward off of the work once Tungsten

Preheat time is complete. This should be a relatively small time value to minimize a long starting arc with high arc voltage. The range of this function is from 0.0 to 02.0 Seconds. It is recommended that the operator stay below 1 second.

NOTE



When oscillation is active for a weld program and either upslope or Downslope time is used, the oscillator's Taper Function will be enabled.

Upslope Time

The Amount of time the controller takes to increase from Start Amps to Primary Amps is called Upslope time. Upslope Time is measured in seconds and can range from 0.0 to 99.9 seconds.

AVC Start Delay

Arc Delay describes the delay the Arc Voltage Control waits beyond Upslope Time before the AVC begins to track and correct for arc voltage errors.

This delay is in seconds and has a range from 0.0 to 99.9 Seconds. It is recommended the time be set as low as possible to allow the AVC to begin compensating for arc voltage errors as quickly as possible once the Primary Amps have been reached.

Travel Delay

Travel Delay is the time the weld head travel carriage is delayed once an arc is established. This delay is typically set to a time close to the Upslope Time setting to allow a weld puddle to form before travel commences. This function is measured in seconds and has a range from 0.0 to 99.9 seconds.

Wire Delay

Wire delay is measured in seconds and has a range from 0.0 to 99.9 seconds and begins counting down once the arc is established. This delay allows the weld puddle to form before wire is added. Typically, this time is set close to the Upslope Time setting.

To go back to the Menus Screen, press the Back Selection Button.

End of Weld Parameters

The End of Weld Parameters (see Figure 42 – End of Weld) are used to provide proper control of the end of welding cycle.



End of Weld		Program# 0001	
Down Slope Time:	04.0	sec	
Final Amps:	070	Amps	
Wire Stop Delay:	00.5	sec	
Wire Retract:	00.3	sec	
Torch Retract:	01.0	sec	
Post Flow:	04.0	sec	
Back			

FIGURE 42 – END OF WELD

The parameters in this menu are:

- Down Slope Time
- Final Amps
- Wire Stop Delay
- Wire Retract
- Torch Retract
- Post Flow

Down Slope Time

Down Slope Time is measured from the moment the Start/ Stop Button is pressed to begin the End of Weld sequence.

Down Slope Time has a range from 0.0 to 99.0 seconds and is important to prevent craters and cracking at the end of the weld (see Figure 2 - Orbital Process Timeline).

Final Amps

Final Amps is the amperage level when Down Slope Time is complete. Once Down Slope Completes, Final Amperage is reached and the welding arc is extinguished. Final Amps can range from 0 to 500 Amps.

Wire Stop Delay

Wire Stop Delay is used to add wire during some portion of Down Slope. Wire is typically fed for no more than 30% of the Down Slope Time, but can be changed to the operators preference.

This value is measured in seconds with a range of 0.0 to 99.9 seconds. This delay time begins counting down at the moment the Start/ Stop button is pressed to begin the End of Weld Sequence.

Wire Retract

Wire Retract is used to pull the wire out of the weld puddle area to prevent the wire from getting stuck to the base material at the end of the cycle. Wire retract begins at the moment the Wire Stop Delay is complete.

The Wire Retract is measured in seconds with a range from 0.0 to 99.0 seconds. It is recommended to set this value as low as possible to prevent the wire from unspooling. The time should be selected to retract the wire approximately 1/2" to 1" in length.

Torch Retract

Torch Retract begins when the arc is extinguished and is measured in seconds from 0 to 99.9. Its main purpose is to remove the Torch from the weld area to prevent the puddle from contacting tungsten, and make manually joggling the tractor easier.

Gas Post-Flow (Post-Flow)

Gas Post Flow is used to provide adequate gas flow to the weld area after the arc is turned off to prevent porosity and contamination of the weld.

This time is measured in seconds, having a range from 0.0 to 99.9 seconds and begins counting down at the moment the arc extinguishes.

Gas Post-Flow should be longer than the Down Slope Time to allow for gas coverage after the arc is turned off. For example, if Down Slope Time is set for 15 Seconds of Gas Post-Flow then the Gas Post-Flow Time should be set to 30.0 Seconds; 15 (Down Slope) + 15 (Post-Flow) = 30 seconds.

NOTE Gas Post Flow must be longer than the down slope time.



Access Control

The Access Control List (see Figure 43 – Access

Control List) allows the supervisor to control what values can be adjusted or changed by the operator. This feature is used in conjunction with the Codes Menu, see Tools section on page 26.

Access Control List		Program# 0001
Return to Weld Screen:	No	
User Limits:	OFF	
Amps Menu:	No	
Volts Menu:	No	
Oscillator Menu:	No	
Wire Menu:	No	
Start of Weld Menu:	No	
End of Weld Menu:	No	

Back		Set	▲	▼
------	--	-----	---	---

FIGURE 43 – ACCESS CONTROL LIST

This list includes the options for:

- Return to Weld Screen
- User limits
- Amps menu
- Volts menu
- Oscillator Menu
- Wire Menu
- Start of Weld Menu
- End of Weld Menu

These values can be set to Yes or No, except for User Limits, which is an On / Off value.

Firmware revision

The Firmware Revision screen (see Figure 44 – Firmware Revision) provides the current revisions of all the program code used in the system. The screen shows the revisions for the:

- LCD controllers
- Pendant Controller
- AVC / Oscillator Controller
- Motor Controller
- CPU Controller-Processor A
- CPU Controller-Processor B

Firmware Revision			
Revision / Checksum			
LCD Controller:	04.12		
Pendent Controller:	04.12	----	
AVC Oscillator Controller:	04.12	----	
Motor Controller:	04.12	----	
CPU Controller-Processor A:	04.12	----	
CPU Controller-Processor B:	04.12	----	

Back				
------	--	--	--	--

FIGURE 44 – FIRMWARE REVISION

This screen is informational only. There are no settings to be changed.

NOTE



This image is provided as a reference only, actual firmware revisions on screen will be different.

Fault Monitoring

Fault monitoring (see Figure 45 – Fault Monitoring Screen) is used to stop the welding process completely when a fault is detected.

The Parameters available to monitor are:

- Gas
- Water
- Amperage
- Voltage

Input values will automatically save into the system.

The Values shown in figure 45 are the recommended input values.

Fault Monitoring		Program# 0001	
	Limit	Reference	
Gas	00.5	00.0	
Water	00.5	00.0	
Amps	20		
Volts	02.0		

Back		GAS	▲	▼
------	--	-----	---	---

FIGURE 45 – FAULT MONITORING

Override settings

Override settings are typically set by the supervisor to allow the operator of the equipment to have some flexibility when using the equipment to accommodate excessive cool or hot days, where welding parameters may need to be modified to achieve the same weld quality (see Figure 46 – Override Settings).

Override Settings		Program# 0001	
Enter Override%	Amps:	0	%
	Volts:	0	%
	Wire:	0	%
	Travel:	0	%
	Osc. Width:	0	%

Back				▼
------	--	--	--	---

FIGURE 46 – OVERRIDE SETTINGS

The override parameters available to set for operator flexibility are:

- Amperage
- Voltage
- Wire
- Travel
- Osc. Width

These parameters can range from 0 to 100 %. 100 % allows for full range. For Example 200 Amps at 100 % would give 0 to 500A. 200 Amps at 50 % would give 0 to 250A. The operator can make changes prior to or during the weld process.

Increments Menu

Increment Values allow the user to determine the step values during welding, when not welding these values have no effect. These values are:

- Amps
- Volts
- Wire
- Travel

This screen has a Reset Selection button (see Figure 47 – Increment Values) to allow the user to quickly reset the increments back to their factory default values.

NOTE



Increment Values are not part of the Program structure and cannot be saved as part of a program. Loading and Saving Programs has no effect on the Increment values. They will retain their values when Programs are loaded or saved.

Increment Values		Program# 0001	
Amperage	1	1 to 50	
Voltage	0.1	0.1 to 50	
Wire Feed	1	1 to 20	
Travel	0.1	0.1 to 50	

Back		Reset	▼	▲
------	--	-------	---	---

FIGURE 47 – INCREMENT VALUES

System Health

The System Health screen provides the current and previous errors for the control systems (see Figure 48 – System Health Screen). The screen shows the errors for the:

- Pendant Controller
- Wire/Travel Controller
- AVC Oscillator Controller
- CPU Controller Processor A
- CPU Controller Processor B

This screen is informational only. There are no settings to be changed.

NOTE



This image is provided as a reference only, actual errors on screen will be different.

System Health Information		Errors	
		Total	Last
Pendant Controller:	0	0	
Wire Travel Controller:	1	48	
AVC Oscillator Controller:	1	48	
CPU Controller-Processor A:	1	48	
CPU Controller-Processor B:	2	48	
OK			

FIGURE 48 – SYSTEM HEALTH INFORMATION

Some errors may be accumulated during normal operation.

MAINTENANCE

The Apex 2100 Orbital Control System is designed for trouble free operation and normally requires minimal preventive care and cleaning. This section provides instructions for maintaining user serviceable items. The suggested repair procedure for all user serviceable items is to remove and replace defective assemblies or parts. If users and service personnel are not familiar with electrical and electronic equipment, the products should be returned to the factory or serviced by factory authorized representatives for service and /or repair.

Power Wave S500

The Welding power source is a Lincoln Electric Power Wave S500, and can be serviced at a Lincoln authorized Service and Repair Center. Refer to the Power Wave S500 Owner's Manual for maintenance schedule and procedure.

NOTE Special weld modes are loaded in the S500 and can be obtained from Arc Products Inc.



Water Cooler

The Water cooler is a Lincoln Electric Cool Arc 55, and can be serviced at a Lincoln authorized Service and Repair Center. Refer to the Cool Arc 55 Owner's Manual for maintenance schedule and procedure.

Control Unit Assembly

The control unit assembly consists of an enclosure housing the major electronic assemblies of the Orbital Control System. Maintenance is generally limited to periodic dusting and blowing out the enclosure using clean dry air.

The user should ensure that the unit is not operated with the cover open or removed. Exercise caution if the unit has been exposed to excessive dust or liquid contamination since such conditions may cause electrical shorting and/or malfunctioning of the electrical/electronics assemblies. The user should consult with the factory if such conditions have occurred. Repair of the control unit assembly is generally limited to a remove and replace operation.

Warning: When repairing the control unit assembly, turn the power switch OFF and disconnect AC Power from the Unit.

NOTE Repair or modification of unauthorized items will void the warranty.



NOTE Observe all precautions for handling electrostatic sensitive devices.



Assemblies and parts which are authorized for user replacement are listed in the Parts List Section on page 40. Replacement should be performed after the user has determined that the part or assembly to be replaced is the cause of a system problem .

Replacement of fuses does not require opening the control unit; however, blowing a fuse may indicate other system problems. The fuse is replaced by turning power on the system to off, unscrewing the fuse holder lid, removing and replacing the blown fuse with a fuse of the same value, then restoring power and turning the system ON to perform a test run.

Replacement of the printed circuit board involves disconnecting the connectors to the board, removing the mounting screws and replacing the board with a new board.

NOTE Calibration is not required when replacing Power Supply or Power Supply Board, it IS required when replacing any other printed circuit boards.



The service person should exercise care while removing boards to ensure that excessive force is not placed on the connectors or components on the board and that the mounting screws are not over tightened.

The boards are held in place by six to nine screws threaded into stand-offs mounted in the enclosure. To remove:

1. Disconnect all necessary harnesses at the connection plugs provided.
2. Remove the mounting screws.
3. Remove board.
4. Install the replacement board.
5. Replace the mounting screws tightening until snug. Do not over-tighten as damage to the board and enclosure standoffs may result.
6. Reconnect all harnesses.

Replacement of other user serviceable items is to be performed according to normal maintenance and repair standards, usually involving the removal of mounting hardware, unplugging the old part or sub-assembly, mounting the replacement part and re-connecting the connectors.

NOTE

See instructions for individual parts before attempting to replace them.

Cable Assembly

Maintenance of the cable assemblies is to periodically remove dust, soot, metal particles, slag, etc., from the cable's insulation and checking for cracking in the insulation and sharp bends in the cable at the connectors. Also, check to be sure the connectors are tightened and seated correctly in their mating receptacles.

NOTE

Repair of the cable assemblies is limited to replacement of defective cable assembly.

Weld Head Assembly

The weld head assembly maintenance should include periodic inspections for worn parts. Further maintenance includes removing excess dust, weld slag, soot, etc., from the assembly. If any connectors or parts are damaged during the inspection operation, the defective parts should be replaced as soon as practical.

NOTE

Repair of the weld head assembly is limited to the replacement of defective parts, as well as adjustment of the weld head assembly's moving parts to remove play between wheels and rails, bushing, rack and pinions or axial play between the slides.

For more detailed maintenance procedures of the weld head assembly, please review the weld head manual.

Preventative Maintenance Schedule

The following schedule is provided to assist in performing timely system maintenance to maintain optimum performance.

More stringent maintenance requirements may be required depending on the work being performed and the requirements of the customer for whom the work is performed.

Monthly Maintenance

Weld Head Assemblies

Proper Function

There should be no play in the weld head assembly. Cable connectors and strain reliefs should be tight and properly seated in their mating receptacles.

Clean slag, dirt and spatter from weld head assembly.

Verify that the weld head assembly functions properly in all aspects.

For maintenance of the weld head assembly, please review the weld head manual.

Quarterly Maintenance

Cables

Check for proper installation.

All cables should be connected tightly to the respective receptacles. Be sure that the cables do not have sharp bends and the insulation is not frayed or cracked.

Semi Annual Maintenance

Control Unit Assembly

Be sure the control unit is turned off and unplugged. Using clean, dry air, blow out dust from the inside of the control unit.

Be sure all connections in the control unit are seated firmly in their receptacles and reconnect the power cord. Turn power on and check for proper operation.

Calibration

Calibration of the controller is required for motor control, amperage, voltage, and display accuracy. The amperage, voltage, and display calibration is done at the factory and should not need re-calibrating. The following steps listed for these adjustments are provided to check the calibration and re-calibrate, if needed.

Software calibration is required when a weld head is changed from one weld head to another or when set by customer requirements for their particular applications.

Calibration is required when changing from one weld head to another because motors have different characteristics and performance even within the same motor type and manufacturer.

The calibration process consists of two steps; Hardware Calibration and Software Calibration. Hardware calibration is done at the factory and ensures the motor control circuitry is performing properly. Software calibration is required to ensure the control unit commands correct motor speeds and displays these speeds accurately on the screens.

When changing weld heads it is only necessary to run a software calibration on the control unit, since the hardware was performing correctly with the previous weld head.

SOFTWARE CALIBRATION

The Software Calibration is vital to the operation of the APEX 2100. By performing the calibration of the software, the travel speed, wire feed speed, and oscillation speeds are set at the correct operating parameters allowing for better control of the weld.

Setup

Wire 1 (and Wire 2 if installed) need to be set to Forward in the Weld Jog Screen. See Operations section for details.

Set torch height to allow free movement as well as plenty of space to cut the wire for Wire Speed Calibration.

CALIBRATION SCREEN

NOTE



Oscillation Calibration is performed in the factory and is only required to be re-done after significant weight or motor changes.

The calibration screen is accessed by pressing the Program Navigation Button, and selecting the Calibrate Selection Button. This screen has two options: OSC Check and Speed CAL.

OSC Check and Speed CAL can be done with the tractor in any position on the work surface. Be sure to allow 6 to 8 inches from the center point in each direction for measurements.

Oscillator (OSC) Check

The Oscillator check measures the voltage necessary for oscillator to travel a specific length. This procedure will automatically populate the Oscillator Speed Value and determine the length (Length 1) necessary for Oscillation Speed Calibration.

Speed CAL

This screen allows the operator to set the calibration speeds for all the software calibrations. All speeds should be set to the minimum speeds that will still allow movement without hesitation (Refer to Table 1 – Minimum Speed Values).

Minimum Speed Values		
Recommended Starting Point		Actual Value
Oscillator Speed	250	
Travel Forward Speed	2.3	
Travel Reverse Speed	2.3	
Wire 1 Speed	007	
Wire 2 Speed	007	

TABLE 1 – MINIMUM SPEED VALUES

NOTE

Verify that these speeds are correct by entering in vales from Table 1 Recommended Starting Point and decreasing speed until movement begins to hesitate, then increasing speed until hesitation stops and movement is smooth. Enter new value into Table 1 Actual Value column if significantly different.

Oscillator Check Screen

From the Calibration Screen press the Osc Check Selection button. This will bring up to the Osc Check Screen.

- 1) Enter in the following Values:

Center	0
Excursion Width	500
Excursion Speed	500
In Dwell	1 Sec
Out Dwell	1 Sec

- 2) Press the On/Off selection Button. The Weld Head should begin to oscillate the full width.
- 3) While the Weld Head is Oscillating highlight the Excursion speed.
- 4) Reduce Excursion Speed until head stops moving or the speed reaches 250. If movement stops increase speed until uninterrupted movement resumes.

NOTE

Verify in both directions of movement.

- 5) Record Excursion Speed Value in Table 1. This value will be used to determine the minimum speed of the Weld Head.
- 6) Measure the actual oscillation distance the weld head travels from extreme in, to extreme out. Record this value for Oscillation Speed Calibration Length 1 Value.

Speed Calibration Screen

- 1) Set the Oscillation Speed to the appropriate value from Table 1.

- 2) Press the Set Min Speed Selection button. This brings up the calibration screen.

- 3) Enter the recorded length from Osc Check procedure into Length 1. This sets the distance of the travel and measures the time it takes to move that distance allowing the processors to calculate the voltage need for the motor to travel at the speed needed for each distance under the 1 inch measurement.

- 4) Press RUN CAL Selection Button to start the calibration cycle.

An indicator will appear at the bottom of the screen as the calibration program is running. When the indicator vanishes the Calibration cycle has been completed for the oscillation. Complete Calibration takes approximately 10 minutes.

- 5) Select the Save Selection button to save the parameters to memory.

Travel Calibration**NOTE**

The Travel Speed sets both the forward and reverse movements of the tractor.

- 1) Using the down arrow, highlight the Travel Forward Speed.
- 2) Enter the appropriate value from Table 1. The head should move without hesitation, if not increase value.
- 3) Press the Set Min Speed Selection button to set the speed. The Software will now highlight the Travel Reverse Speed.
- 4) Enter the appropriate value from Table 1. The head should move without hesitation, if not increase value.
- 5) Press the Set Min Speed Selection button to set the speed. This will bring up the calibration screen.
- 6) Press the Reset Selection button to reset all fields to zero.
- 7) If not already selected, use the Arrow Selection button to highlight Length 1.

- 8) Mark the tungsten position.
- 9) Press the Run CAL Selection button to start the calibration cycle. An indicator will appear at the bottom of the screen as the calibration program is running. When the indicator vanishes the Calibration cycle has been completed for the Length.
- 10) Measure the distance traveled and mark the tungsten position so that the next length can be measured.
- 11) Enter the measurement into the selected Length.
- 12) Use the Arrow Selection button to highlight the next Length.
- 13) Repeat Steps 8 - 11 for Length 2 through 8.
- 14) Press the Save Selection button to save the parameters to the memory.

Wire Calibration

Wire 1

- 1) Using the down arrow highlight the Wire 1 Speed.
- 2) Enter the appropriate value from Table 1 using the Encoder. The wire should move without hesitation, if not increase the value.
- 3) Press the Set Min Speed Selection button to set the speed. This will bring up the Calibration Screen.
- 4) Press the Reset Selection button to reset all fields to zero.
- 5) Cut the wire at the tip of the wire feeder.
- 6) Using the Arrow Selection Button highlight Length 1.
- 7) Press Run CAL Selection Button to start the calibration cycle. An indicator will appear at the bottom of the screen as the calibration program is running. When the indicator vanishes then the Calibration cycle has been completed for the Length.
- 8) Measure the wire fed and enter the measurement into the selected Length.

- 9) Cut the wire so that the next length can be measured.
- 10) Use the Arrow Selection button to highlight the next Length.
- 11) Repeat steps 7 through 10 for Lengths 2 – 4.
- 12) Press the Save Selection button to save the parameters to the memory.

Wire 2

Follow steps 1 through 12 from Wire 1 calibration instructions. In Step 1 choose Wire 2 Speed.

A large, empty rectangular box with a thin black border, occupying the majority of the page. This area is intended for handwritten notes.

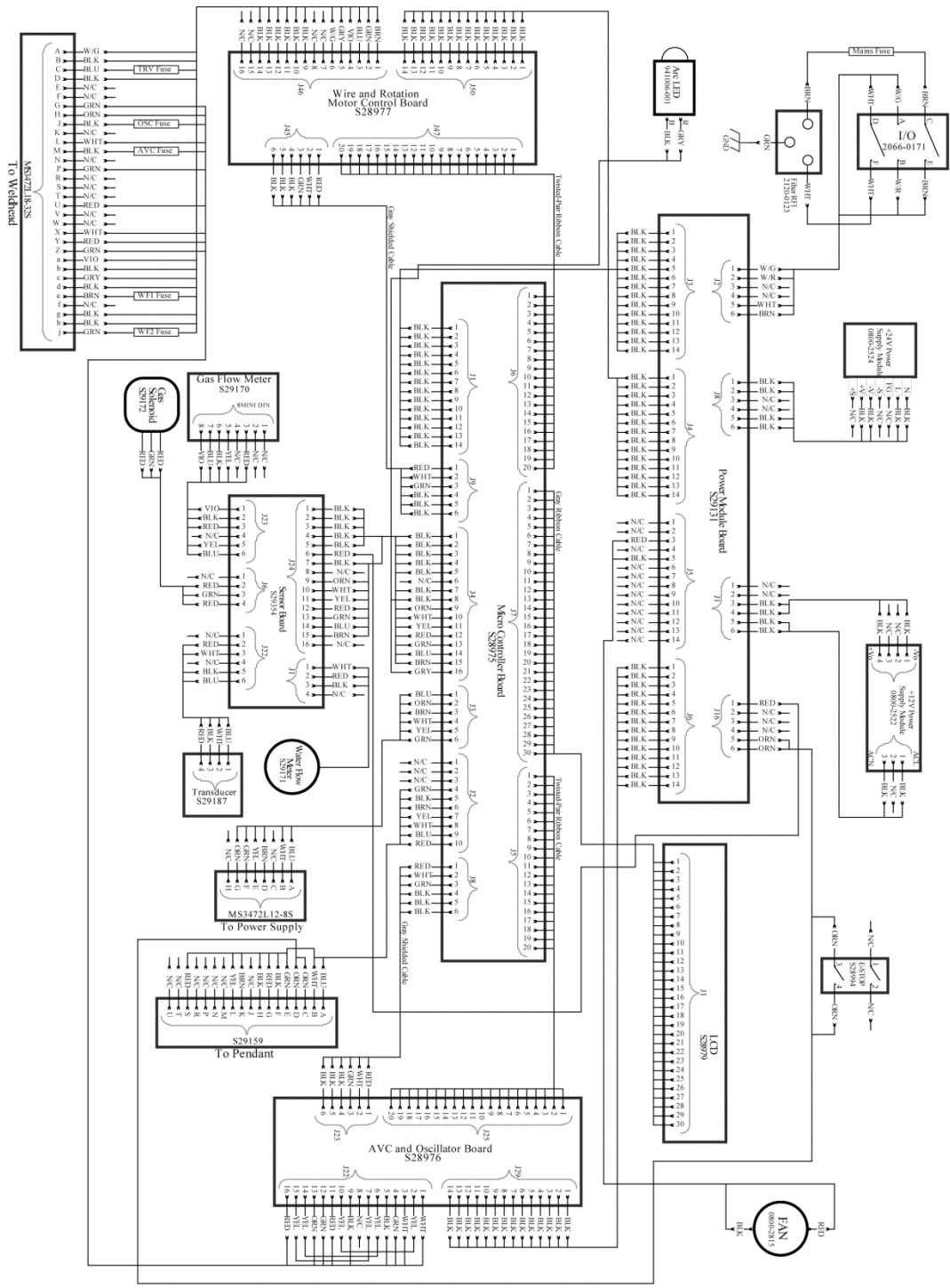

FIGURE 49 – APEX 2100 WIRING DIAGRAM

PARTS LIST FOR

APEX 2100

Orbital Control System

This parts list is provided as an informative guide only.

It was accurate at the time of printing. These pages are only updated on the Service Navigator DVD and in Lincoln Electric's official Parts Book (BK-34).

When ordering parts, always refer to Lincoln Electric's official Parts Book (BK-34) for the latest pages.

APEX 2100 ORBITAL CONTROL SYSTEM



ILLUSTRATION OF PARTS

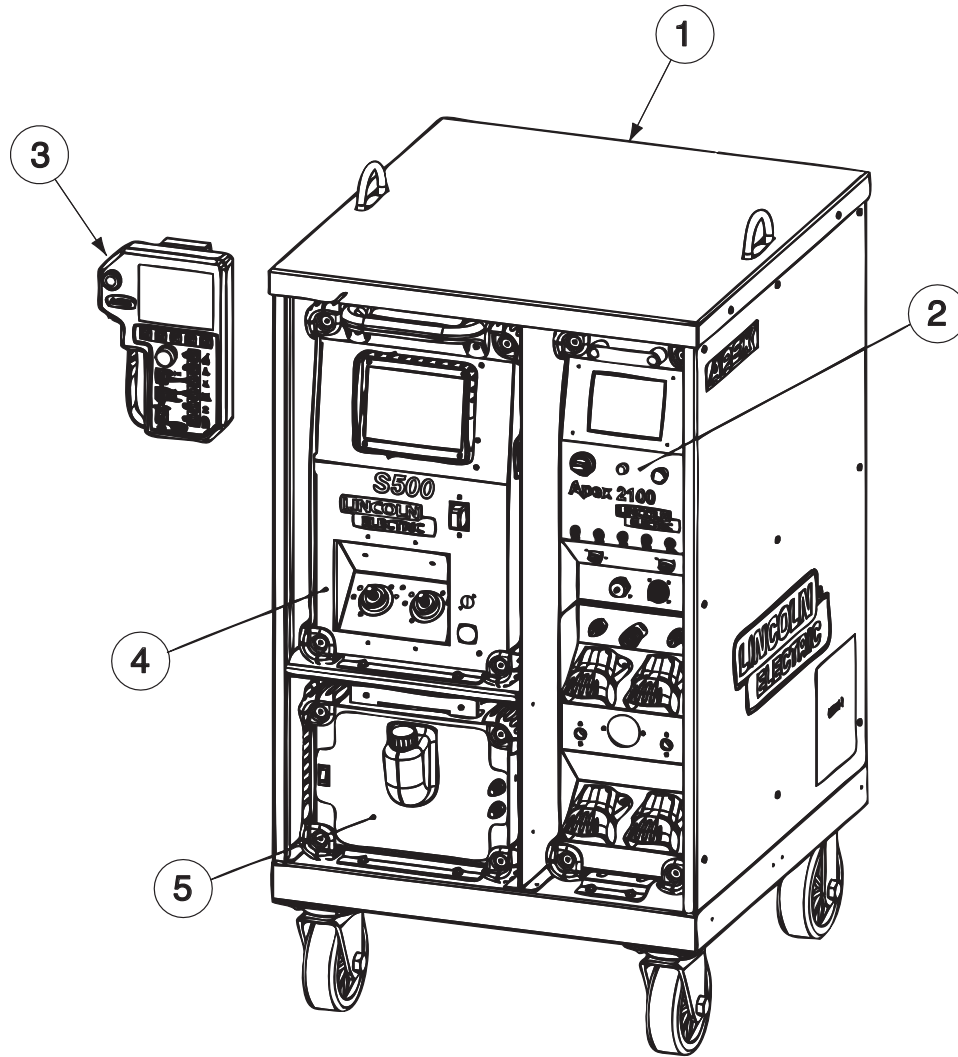

APEX 2100 Orbital Control System

Do Not use this Parts List for a machine if its code number is not listed. Contact the Service Department for any code numbers not listed.

Use the Illustration of Sub-Assemblies page and the table below to determine which sub assembly page and column the desired part is located on for your particular code machine.

Sub Assembly Item No. ↔	1	2	2	2	2	2	2	2	2
SUB ASSEMBLY PAGE NAME ↔	Apex Cabinet	Apex 2100 (Right Side)	Apex 2100 (Left Side)	Apex 2100 (Front Panel)	Apex 2100 (Rear Panel)	Gas Solenoid Harness & Flow Monitor	Current Transducer	Tubing	Water Flow Sensor Assembly
PAGE NO. →	P-715-C	P-715-D	P-715-E	P-715-F	P-715-G	P-715-H	P-715-J	P-715-K	P-715-L
CODE NO. ↓									
70302	1	1	1	1	1	1	1	1	1



APEX 2100 Orbital Control System

Do Not use this Parts List for a machine if its code number is not listed. Contact the Service Department for any code numbers not listed.

Use the Illustration of Sub-Assemblies page and the table below to determine which sub assembly page and column the desired part is located on for your particular code machine.

↔ Sub Assembly Item No.	3		4	5					
SUB ASSEMBLY PAGE NAME ↔	Pendant	Cables and Hoses	Power Wave S5000	Cool Arc 55					
→ PAGE NO.	P-715-M	P-715-N							
CODE NO. ↓									
70302	1	1							



NOTES

APEX 2100 ORBITAL CONTROL SYSTEM



Apex Cabinet

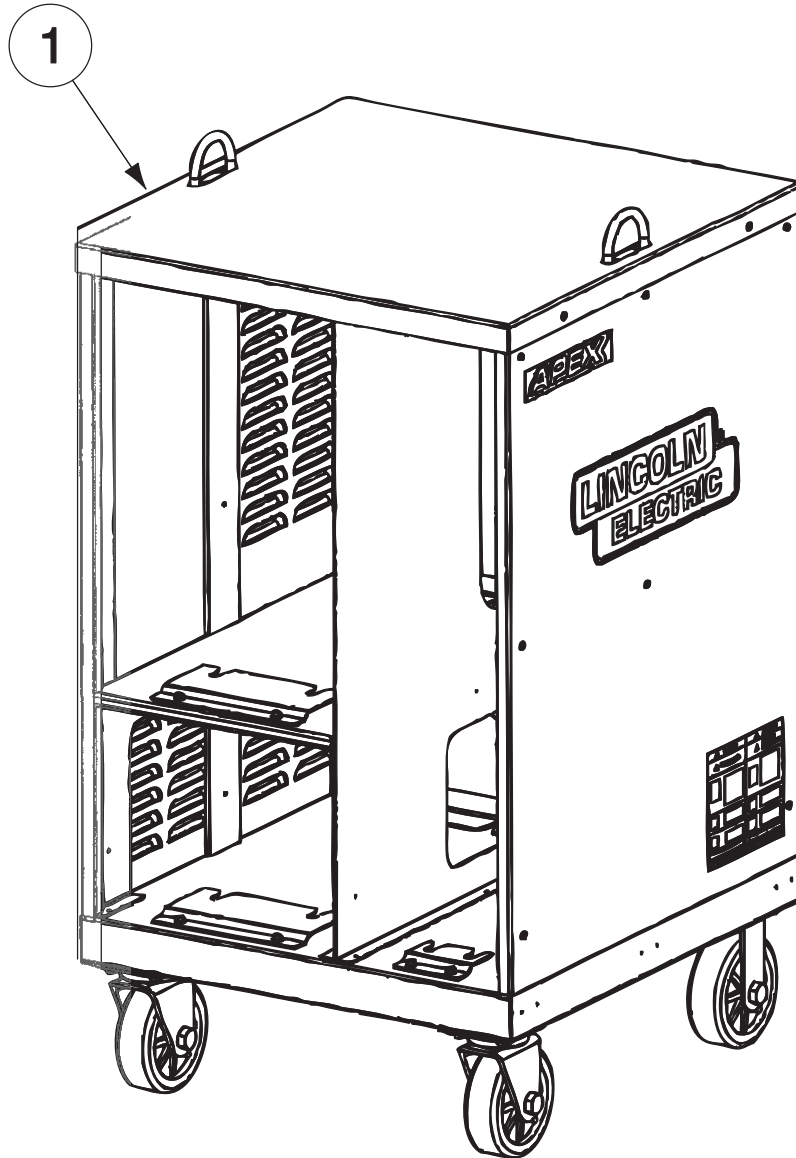

Indicates a change this printing.

Use only the parts marked "x" in the column under the heading number called for in the model index page.

ITEM	DESCRIPTION	PART NO.	QTY.	1	2	3	4	5	6	7	8	9
1	Control Unit, Control Assembly (M24225), Includes: Apex Cabinet	K52075-1	1	X								



Apex 2100 (Right Side)

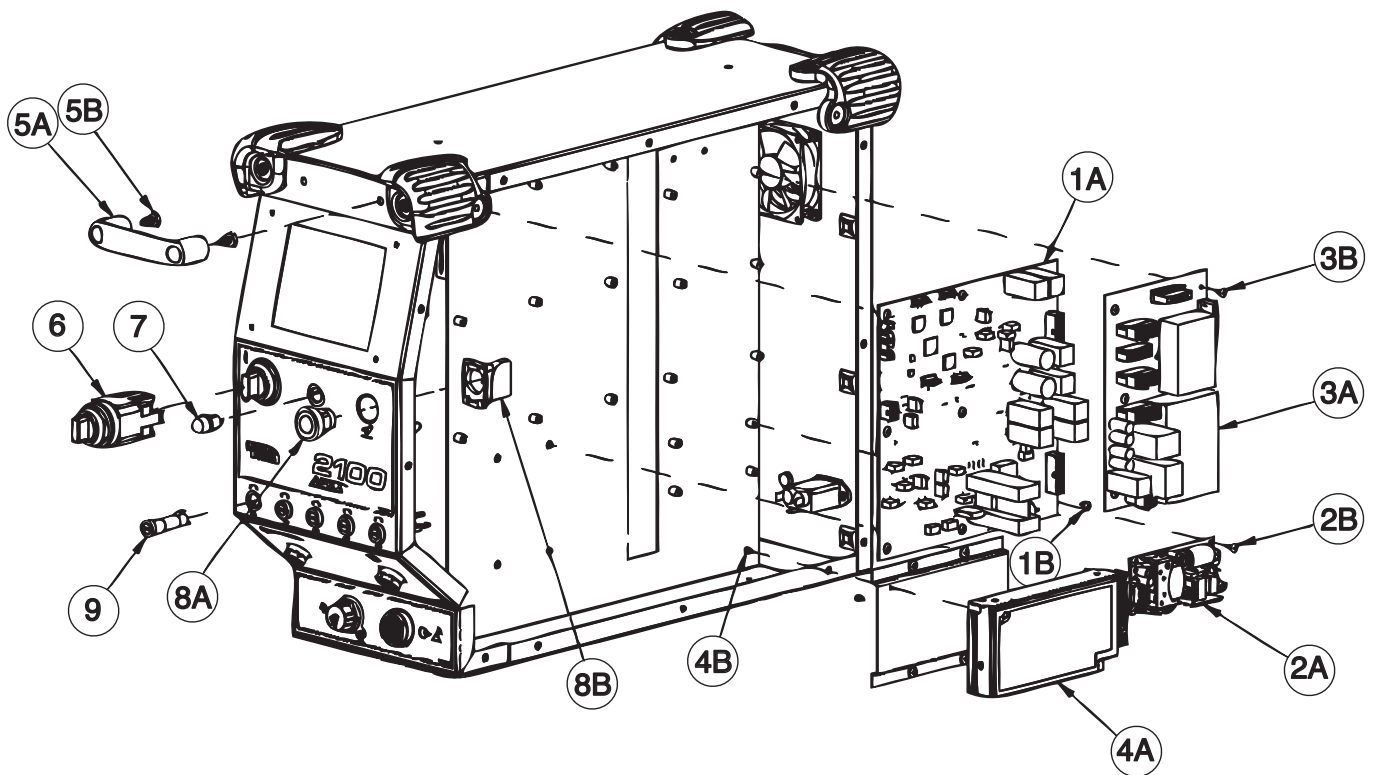

Indicates a change this printing.

Use only the parts marked "x" in the column under the heading number called for in the model index page.

ITEM	DESCRIPTION	PART NO.	QTY.	1	2	3	4	5	6	7	8	9
1	Control Unit, Control Assembly (M24225), Includes: AVC/OSC Kit	S29560-1	1	X								
1A	AVC/OSC PCB		1	X								
1B	Truss Head Screw #6-32		9	X								
2	Power Supply Module Kit	S29560-2	1	X								
2A	Power Supply Module		1	X								
2B	Truss Head Screw #6-32		4	X								
3	Power Module Board Kit	S29560-3	1	X								
3A	Power Module Board		1	X								
3B	Truss Head Screw #6-32		6	X								
4	Power Module Kit	S29560-4	1	X								
4A	TDK Lambda HWS100_24A		1	X								
4B	Pan Head Screw M3 x 0.5 x 6		2	X								
5	Controller Handle Kit	S29560-5	1	X								
5A	Handle, Controller		2	X								
5B	1/4-20 Hex Bolt		2	X								
6	Power Switch	S29560-6	1	X								
7	LED Indicator Yellow	S29560-7	1	X								
8	On/Off Button Kit	S29560-8	1	X								
8A	Push Button Operator		1	X								
8B	Push Button Contact Block		1	X								
9	Fuse Holder Shock Safe	S29560-9	1	X								



Apex 2100 (Left Side)

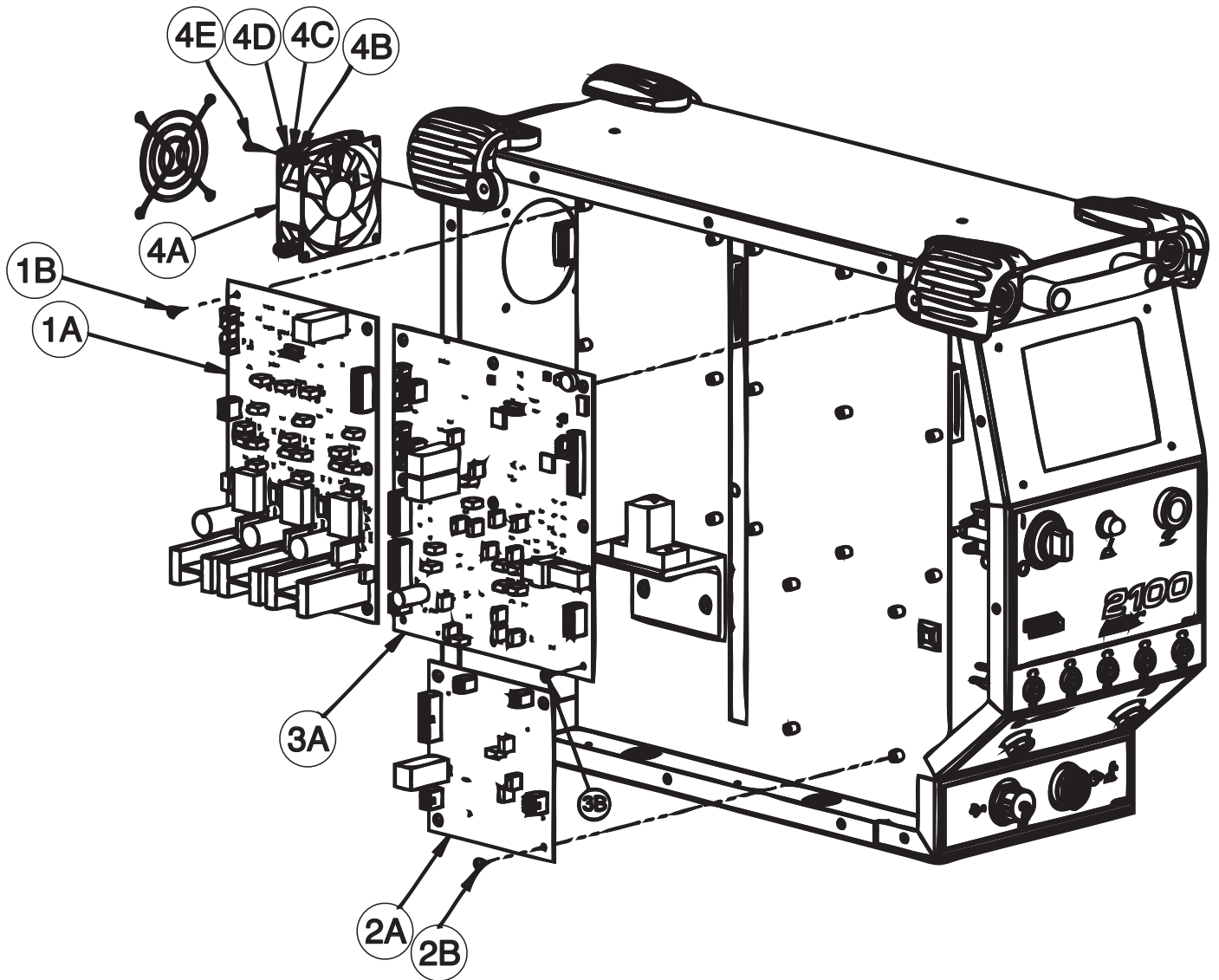

Indicates a change this printing.

Use only the parts marked "x" in the column under the heading number called for in the model index page.

ITEM	DESCRIPTION	PART NO.	QTY.	1	2	3	4	5	6	7	8	9
1	Control Unit, Control Assembly (M24225), Includes:	S29560-10	1	X								
1A	Rotation Wire Board Kit		1	X								
1B	Rotation/Wire Board Assembly		6	X								
2	Truss Head Screw #6-32	S29560-11	1	X								
2A	Monitor Sensor Board Kit		1	X								
2B	Monitor/Sensor Board		4	X								
3	Truss Head Screw #6-32	S29560-12	1	X								
3A	Microprocessor Board Kit		1	X								
3B	Microprocessor Board Assembly		7	X								
4	Truss Head Screw #6-32	S29560-13	1	X								
4A	Fan Harness Kit		1	X								
4B	Fan Harness Assembly		4	X								
4C	Nut #6-32		4	X								
4D	Spring Lock Washer 6		4	X								
4E	Washer 6	4	X									
	Pan Head Screw #6-32		4	X								



Apex 2100 (Front Panel)

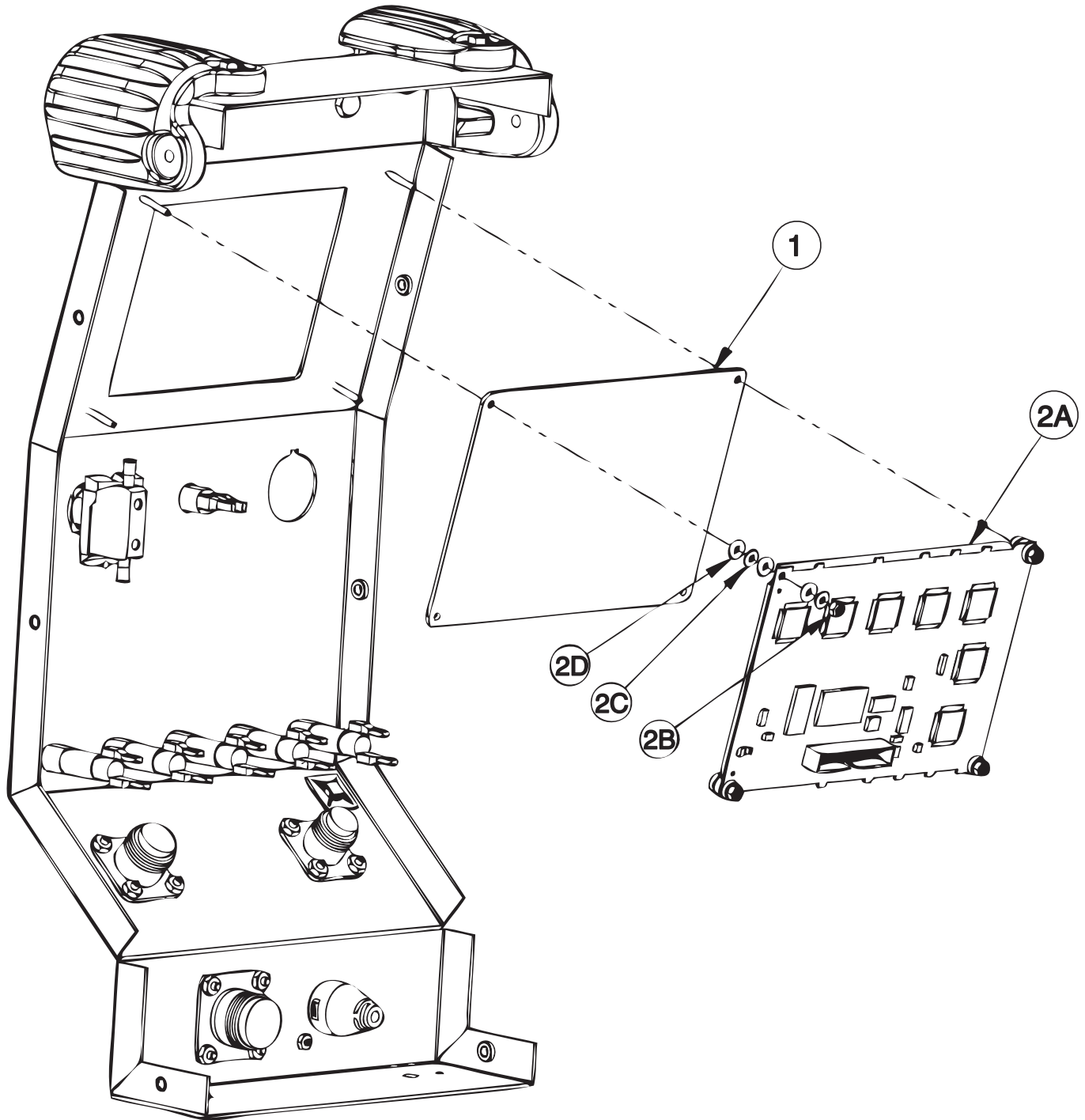

Indicates a change this printing.

Use only the parts marked "x" in the column under the heading number called for in the model index page.

ITEM	DESCRIPTION	PART NO.	QTY.	1	2	3	4	5	6	7	8	9
1	Control Unit, Control Assembly (M24225), Includes: LCD Cover Plate	S29182	1	X								
2	LCD Kit	S29560-14	1	X								
2A	LCD		1	X								
2B	Lock Nut 4-40		4	X								
2C	Washer 4		8	X								
2D	"O" Ring 104		12	X								

Apex 2100 (Rear Panel)

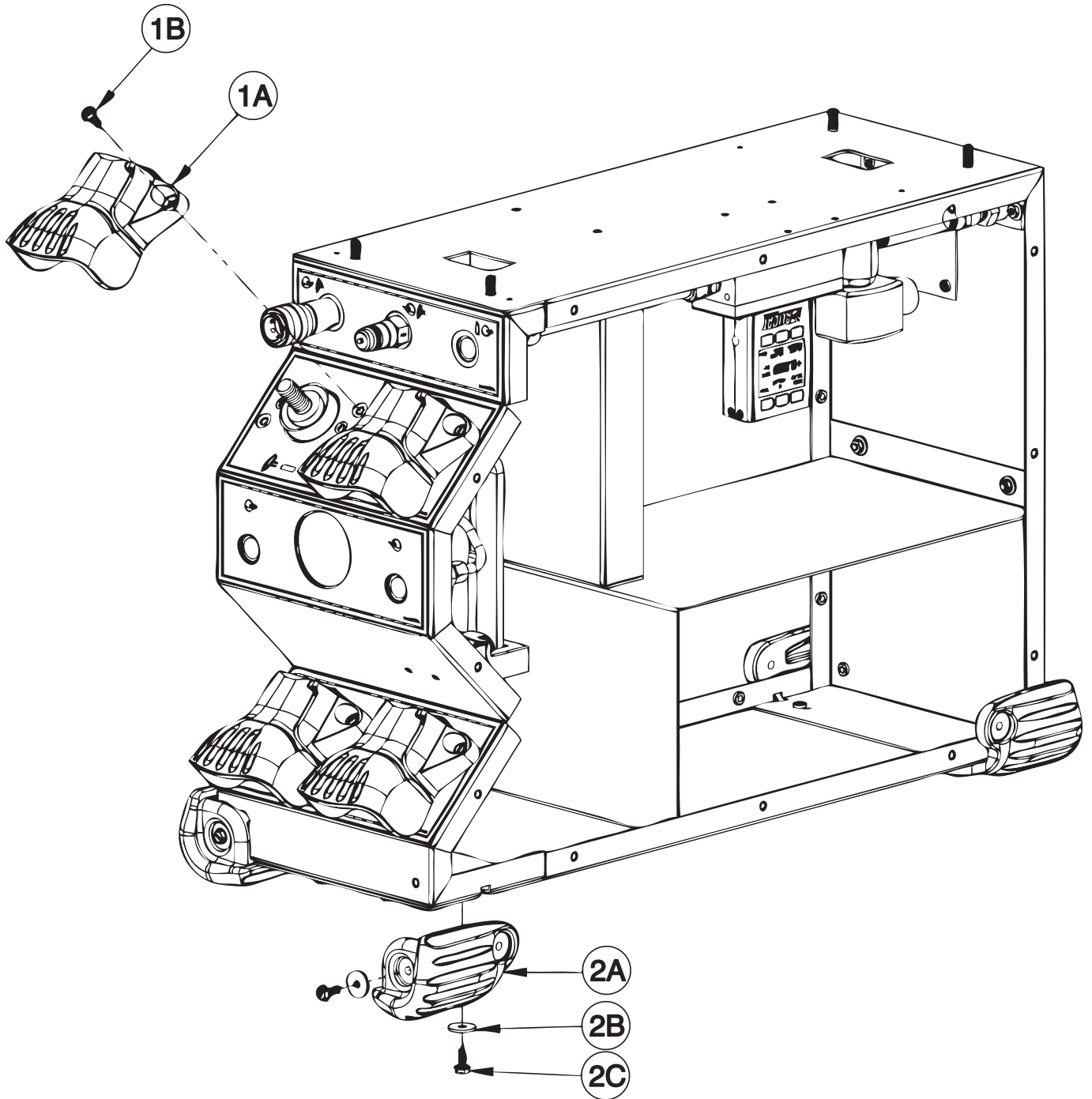

Indicates a change this printing.

Use only the parts marked "x" in the column under the heading number called for in the model index page.

ITEM	DESCRIPTION	PART NO.	QTY.	1	2	3	4	5	6	7	8	9
1	Control Unit, Monitor Assembly (M24226), Includes:	S29560-15	1	X								
1A	Output Stud Kit		1	X								
1B	Stud Cover (4 per Unit)		2	X								
2	Corner Cap Kit	S29560-16	1	X								
2A	Corner Cap (4 per Unit)		1	X								
2B	Plain Washer		2	X								
2C	Screw #10-32		2	X								



Gas Solenoid Harness & Flow Monitor

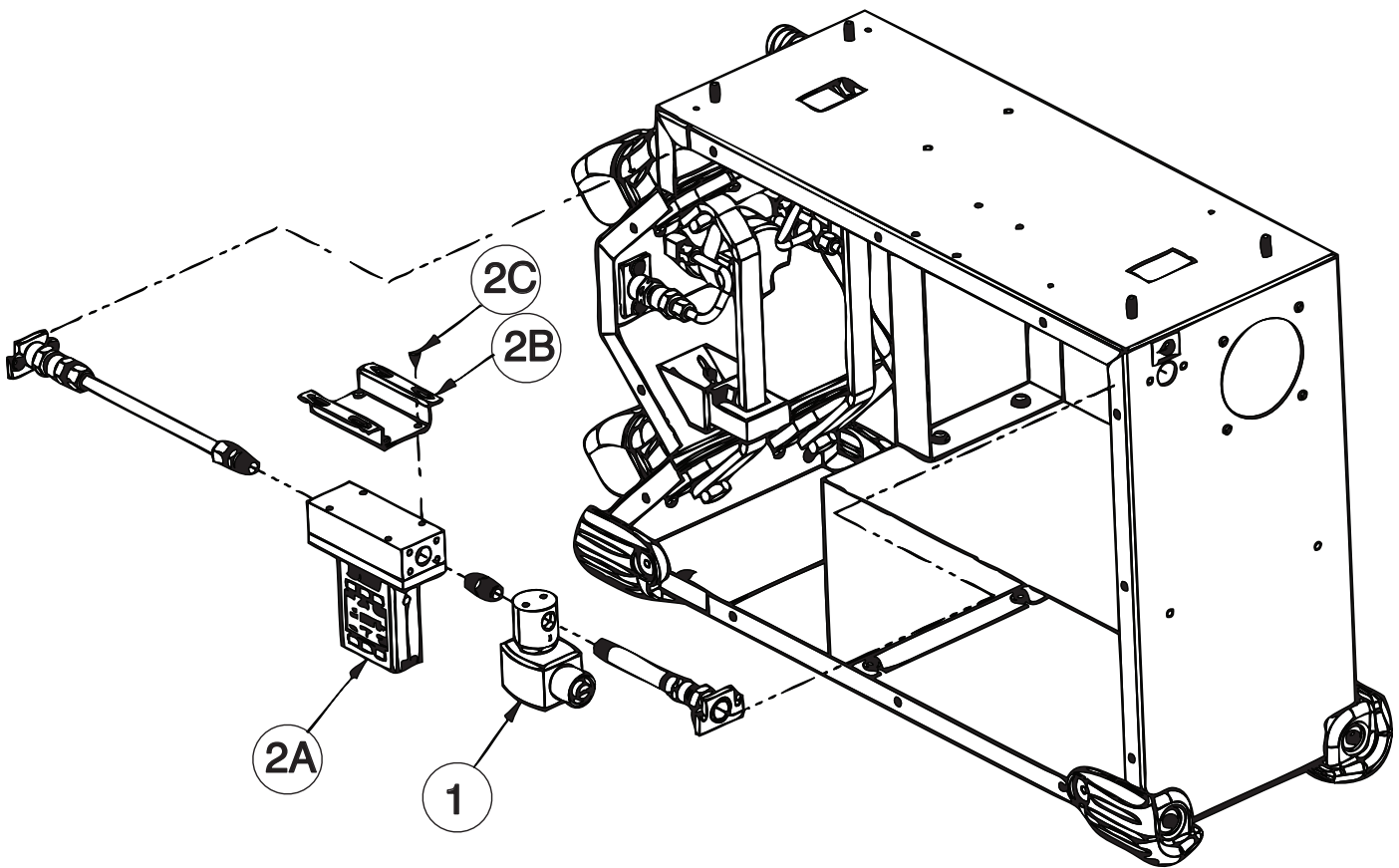

Indicates a change this printing.

Use only the parts marked "x" in the column under the heading number called for in the model index page.

ITEM	DESCRIPTION	PART NO.	QTY.	1	2	3	4	5	6	7	8	9
1	Control Unit, Monitor Assembly (M24226), Includes: Gas Solenoid Harness	M24292	1	X								
2	Flow Monitor Kit	S29560-17	1	X								
2A	Flow Monitor		1	X								
2B	Gas Meter Mount		1	X								
2C	Pan Head Screw #8-32		8	X								



Current Transducer

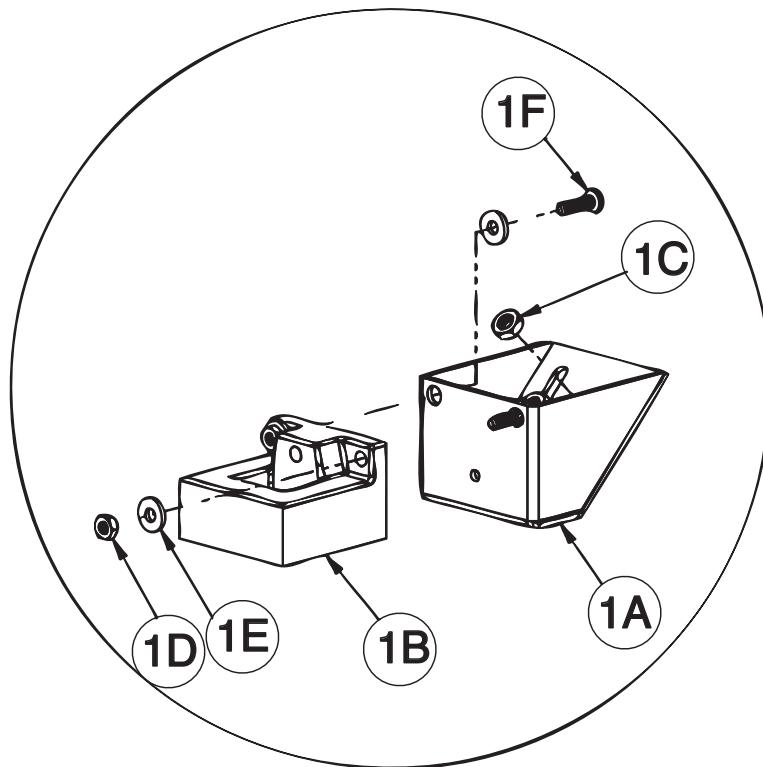
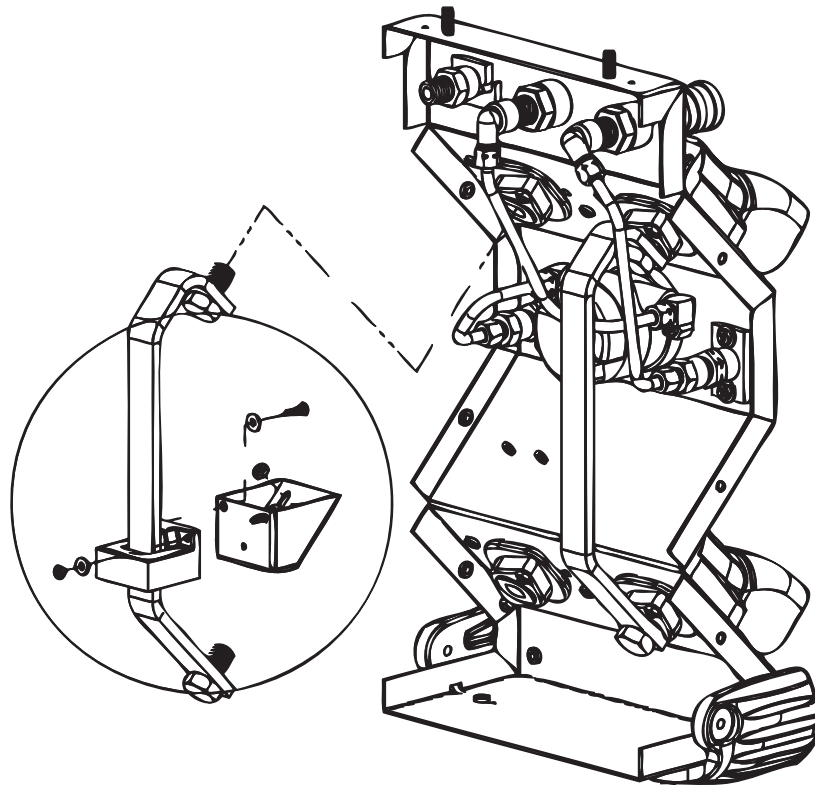

Indicates a change this printing.

Use only the parts marked "x" in the column under the heading number called for in the model index page.

ITEM	DESCRIPTION	PART NO.	QTY.	1	2	3	4	5	6	7	8	9
1	Control Unit, Montior Assembly, (M24226), Includes:	S29560-18	1	X								
1A	Current Transducer Kit		1	X								
1B	LEM Support		1	X								
1C	Current Transducer (500A)		2	X								
1D	Nut #10-32 (Undersize)		2	X								
1E	Nut #6-32 (Undersize)		4	X								
1F	Washer		2	X								
	Pan Head Screw #6-32											



Tubing

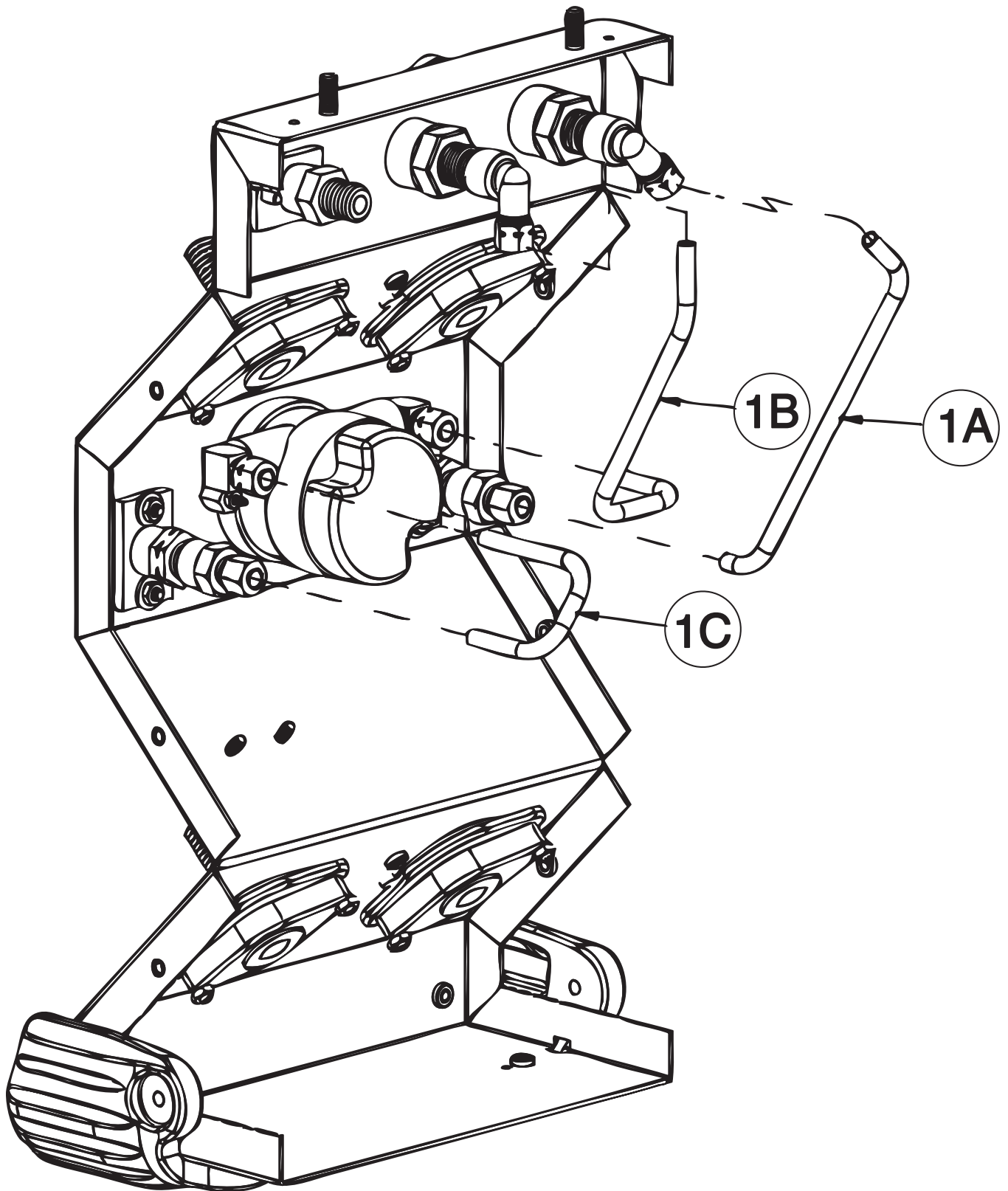

Indicates a change this printing.

Use only the parts marked "x" in the column under the heading number called for in the model index page.

ITEM	DESCRIPTION	PART NO.	QTY.	1	2	3	4	5	6	7	8	9
1	Control Unit, Monitor Assembly (M24226), Includes: Tubing Kit	S29560-19	1	X								
1A	Tubing 1/4 OD 6.45"		1	X								
1B	Tubing 1/4 OD 6.47"		1	X								
1C	Tubing 1/4 OD 4.76"		1	X								



Water Flow Sensor Assembly

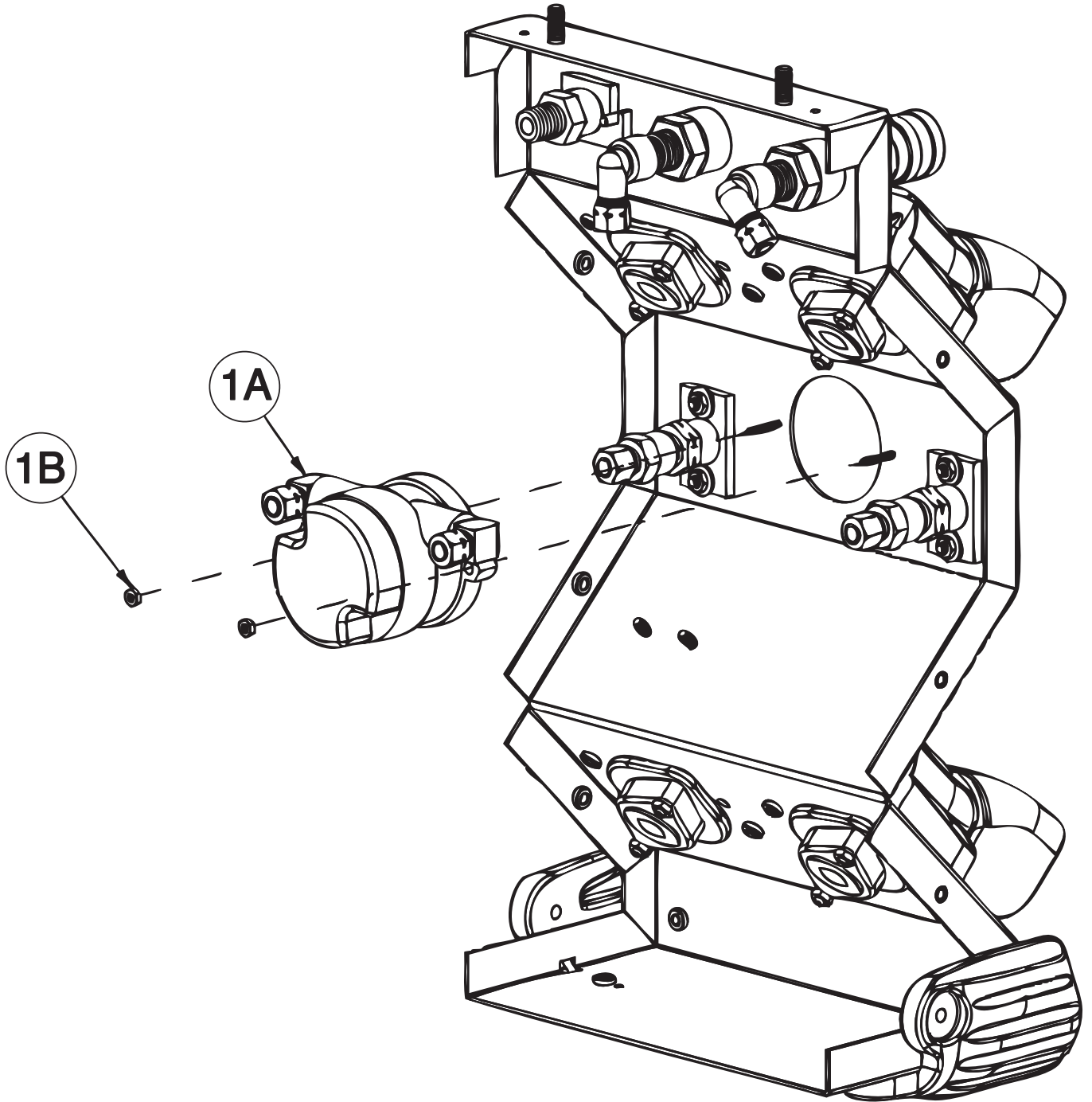

Indicates a change this printing.

Use only the parts marked "x" in the column under the heading number called for in the model index page.

ITEM	DESCRIPTION	PART NO.	QTY.	1	2	3	4	5	6	7	8	9
1	Control Unit, Monitor Assembly (M24226), Includes:	S29560-20	1	X								
1A	Flow Sensor Kit		1	X								
1B	Water Flow Sensor Assembly Nut #6-32 (Undersize)		2	X								



Pendant

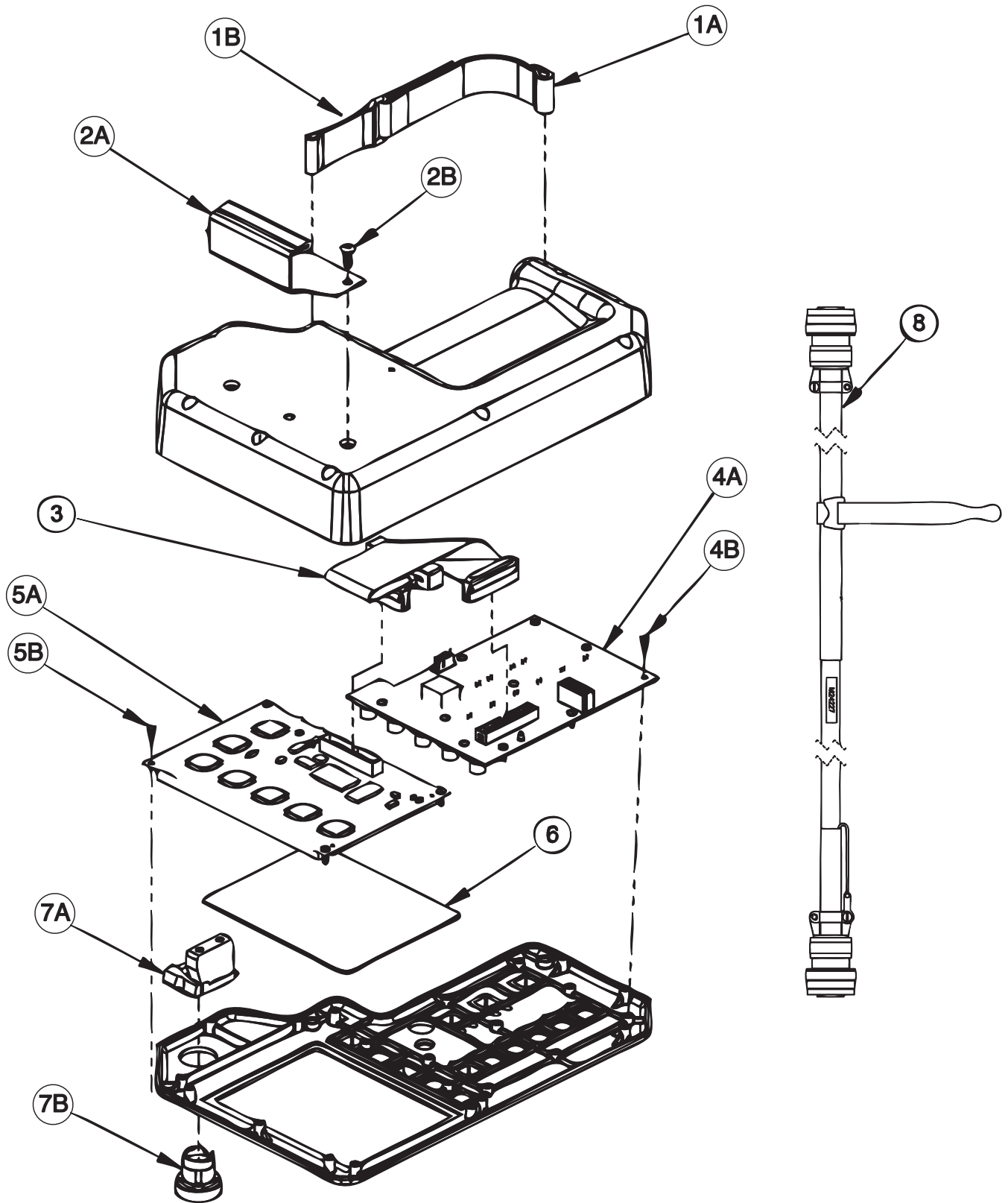

Indicates a change this printing.

Use only the parts marked "x" in the column under the heading number called for in the model index page.

ITEM	DESCRIPTION	PART NO.	QTY.	1	2	3	4	5	6	7	8	9
1	Pendant, (K52074), Includes:											
	Strap	S29560-21	1	X								
1A	Strap A		1	X								
1B	Strap B		1	X								
2	Pendant Hook Kit	S29560-22	1	X								
2A	Pendant Hook Assembly		1	X								
2B	Screw #10-24		3	X								
3	Pendant Ribbon Cable Assembly	M24202	1	X								
4	Pendant Board Kit	S29560-23	1	X								
4A	Pendant Software Board		1	X								
4B	Pan Head Screw 4-20		9	X								
5	LCD Kit	S29560-14	1	X								
5A	LCD		1	X								
5B	Lock Nut 4-40		4	X								
	Washer 4 (used in Control Unit Only)		8	X								
	"O" Ring 104 (used in Control Unit Only)		12	X								
6	Screen Protector	M24152	1	X								
7	On/Off Button Kit	S29560-8	1	X								
7A	Push Button Contact Block		1	X								
7B	Push Button Operator		1	X								
8	Apex Pendant Cable	K52076-25	1	X								

Cables and Hoses

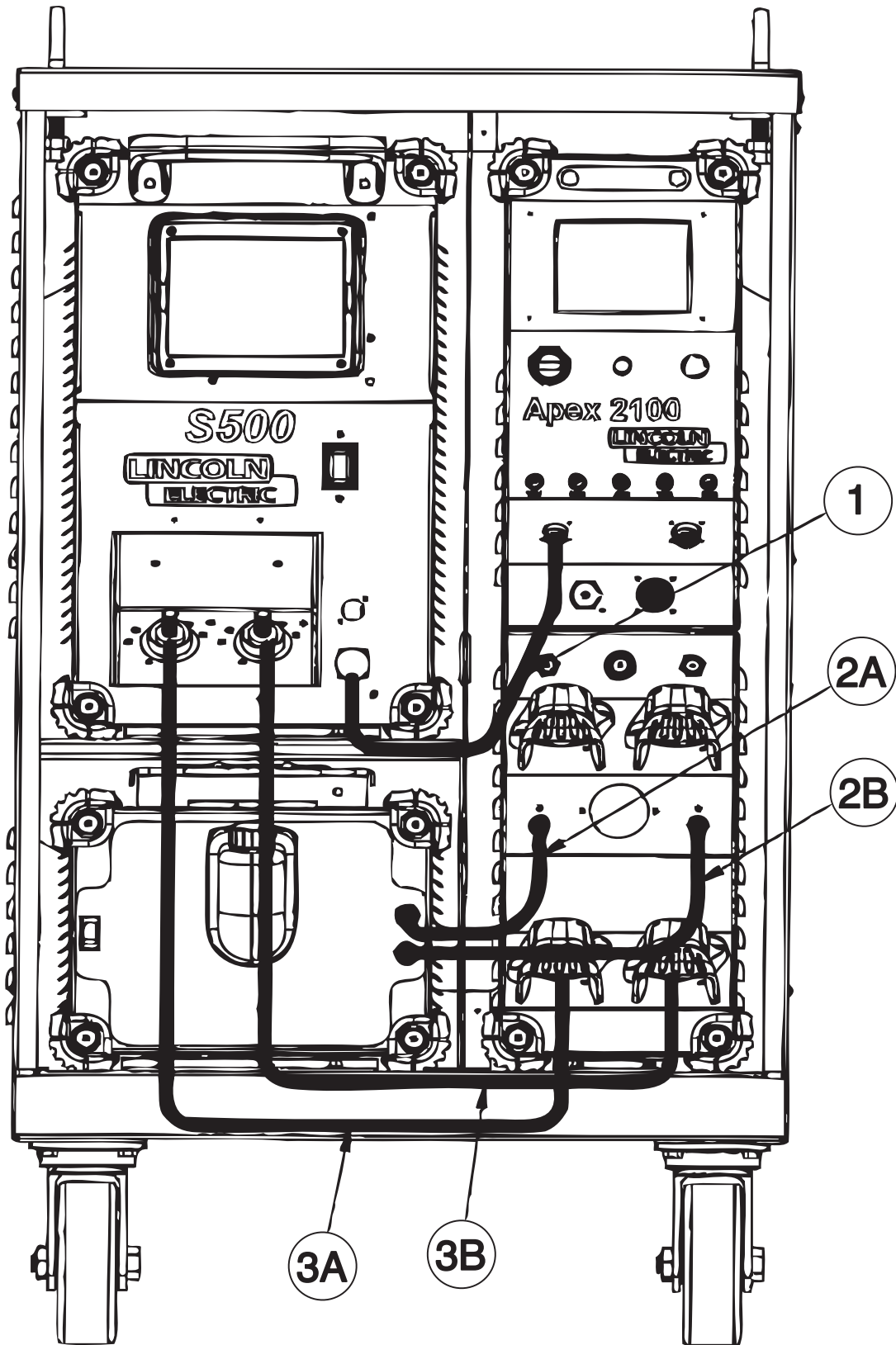

Indicates a change this printing.

Use only the parts marked "x" in the column under the heading number called for in the model index page.

ITEM	DESCRIPTION	PART NO.	QTY.	1	2	3	4	5	6	7	8	9
1	Cables and Hoses Includes: Power Supply Control Cable	S29008	1	X								
2	Water Hose Kit	S29560-24	1	X								
2A	Water Inlet Hose		1	X								
2B	Water Outlet Hose		1	X								
3	Work Lead Power Cable Kit	S29560-25	1	X								
3A	Lead Power Cable		1	X								
3B	Work Power Cable		1	X								



Index

A

amperage..... 6, 7, 8, 19, 21, 23, 26, 27, 28, 33
 Amps Screen 18, 19
 Arc Delay 27
 Arc Voltage Control..... 1, 2, 7, 13, 27
 AVC ii, 1, 2, 7, 8, 9, 13, 20, 21, 22, 26, 27, 29, 30

B

Background Amps 6, 7, 18, 19, 27
 background voltage 20
 Background Wire speed..... 23

C

calibration 33
 Calibration..... i, 15, 24, 25, 31, 33, 34, 35
 Codes 25

D

Deadband 7, 8, 20, 21
 direction 16, 23
 Down Slope 27, 28

E

Emergency Stop 2
 encoder..... 1, 13, 16, 35
 End of Weld 15, 26, 27, 28
 excursion 19

F

Fault Monitoring 26, 29
 Final Amps..... 27, 28

G

Gas i, 1, 12, 16, 17, 26, 28, 29
 gas flow..... 28
 GTAW 1

H

High Frequency 2, 26

I

In Dwell 5, 7, 22, 34
 Independent Pulse i, 6, 7, 8

J

JOG i, ii, 16

L

LCD..... 1, 2, 13, 14, 15, 29
 Lift-Arc..... 2
 load 15, 24
 lockout..... 20

M

Menus Screen 25, 26
 microprocessor..... 1, 13
 Monitor 2

N

new program 15

O

orbital 1, 2, 6, 11, 27, 28, 31
 Orbital 1
 Oscillation .. 1, 5, 6, 7, 8, 13, 19, 20, 21, 22, 23, 25, 33, 34
 Oscillator i, 2, 5, 6, 19, 22, 25, 28, 29, 30, 33
 OSCILLATOR i, 5, 17, 22
 Oscillator Center i, 5
 oscillator check..... 33
 Oscillator Screen..... 22
 Out Dwell i, 5, 7, 8, 19, 22, 34
 Override Settings 26, 29

P

preheat 26
 pre-purge 13
 Primary Amps..... 6, 7, 17, 18, 19, 26, 27
 Primary Voltage..... 20, 21
 Primary Width..... 6, 18
 Primary Wire Speed 8, 23
 Program Menus..... 15
 Pulses per Second 6
 pulsing..... 6, 21

R

rotation 14

S

save 24, 25, 26, 28, 29, 34, 35
 Sensitivity 7, 8, 20, 21
 Sensor..... 2
 Start Amps 26, 27
 Start Gap..... 26, 27
 Start of Weld 15, 26, 27, 28
 Start/Stop 14
 supervisor 25, 28, 29
 Sync to Oscillation..... 6, 7, 8

T

Taper i, 6, 27
 TIG 1
 Tools Menu 25
 torch height 16, 33
 Torch Retract 27, 28
 tractor 11, 16, 17, 34
 Travel 1, 9, 14, 16, 17, 18, 19, 26, 27, 29, 30, 33, 34
 tungsten 1, 2, 26, 28, 34

U

upslope 6, 27
 Usage Conventions 14
 USB 2, 15, 24

V

Voltage i, 1, 2, 7, 9, 13, 14, 17, 20, 21, 27, 29, 30
 Volts Screen 20

W

Water i, 2, 11, 12, 29, 31
 Waveform 6, 7, 8
 weld head 1, 2, 5, 16, 17, 22, 23, 27, 32, 33, 34
 Weld Screen 17, 22, 28
 Width i, 5, 6, 17, 19, 22, 29, 34
 Wire 1, 2, 8, 14, 16, 17, 23, 26, 27, 28, 29, 30, 33, 35

			
WARNING	<ul style="list-style-type: none"> ● Do not touch electrically live parts or electrode with skin or wet clothing. ● Insulate yourself from work and ground. 	<ul style="list-style-type: none"> ● Keep flammable materials away. 	<ul style="list-style-type: none"> ● Wear eye, ear and body protection.
Spanish AVISO DE PRECAUCION	<ul style="list-style-type: none"> ● No toque las partes o los electrodos bajo carga con la piel o ropa mojada. ● Aislese del trabajo y de la tierra. 	<ul style="list-style-type: none"> ● Mantenga el material combustible fuera del área de trabajo. 	<ul style="list-style-type: none"> ● Protéjase los ojos, los oídos y el cuerpo.
French ATTENTION	<ul style="list-style-type: none"> ● Ne laissez ni la peau ni des vêtements mouillés entrer en contact avec des pièces sous tension. ● Isolez-vous du travail et de la terre. 	<ul style="list-style-type: none"> ● Gardez à l'écart de tout matériel inflammable. 	<ul style="list-style-type: none"> ● Protégez vos yeux, vos oreilles et votre corps.
German WARNUNG	<ul style="list-style-type: none"> ● Berühren Sie keine stromführenden Teile oder Elektroden mit Ihrem Körper oder feuchter Kleidung! ● Isolieren Sie sich von den Elektroden und dem Erdboden! 	<ul style="list-style-type: none"> ● Entfernen Sie brennbares Material! 	<ul style="list-style-type: none"> ● Tragen Sie Augen-, Ohren- und Körperschutz!
Portuguese ATENÇÃO	<ul style="list-style-type: none"> ● Não toque partes elétricas e electrodos com a pele ou roupa molhada. ● Isole-se da peça e terra. 	<ul style="list-style-type: none"> ● Mantenha inflamáveis bem guardados. 	<ul style="list-style-type: none"> ● Use proteção para a vista, ouvido e corpo.
Japanese 注意事項	<ul style="list-style-type: none"> ● 通電中の電気部品、又は溶材にヒフやぬれた布で触れないこと。 ● 施工物やアースから身体が絶縁されている様にして下さい。 	<ul style="list-style-type: none"> ● 燃えやすいものの側での溶接作業は絶対にしてはなりません。 	<ul style="list-style-type: none"> ● 目、耳及び身体に保護具をして下さい。
Chinese 警告	<ul style="list-style-type: none"> ● 皮肤或湿衣物切勿接触带电部件及焊缝。 ● 使你自已与地面和工件绝缘。 	<ul style="list-style-type: none"> ● 把一切易燃物品移离工作场所。 	<ul style="list-style-type: none"> ● 佩戴眼、耳及身体劳动保护用具。
Korean 위험	<ul style="list-style-type: none"> ● 전도체나 용접봉을 젖은 헝겍 또는 피부로 절대 접촉치 마십시오. ● 모재와 접지를 접촉치 마십시오. 	<ul style="list-style-type: none"> ● 인화성 물질을 접근 시키지 마십시오. 	<ul style="list-style-type: none"> ● 눈, 귀와 몸에 보호장구를 착용하십시오.
Arabic تحذير	<ul style="list-style-type: none"> ● لا تلمس الأجزاء التي يسري فيها التيار الكهربائي أو الألكترود بجلد الجسم أو بالملايس المبللة بالماء. ● ضع عازلا على جسمك خلال العمل. 	<ul style="list-style-type: none"> ● ضع المواد القابلة للاشتعال في مكان بعيد. 	<ul style="list-style-type: none"> ● ضع أدوات وملابس واقية على عينيك وأذنيك وجسمك.

READ AND UNDERSTAND THE MANUFACTURER'S INSTRUCTION FOR THIS EQUIPMENT AND THE CONSUMABLES TO BE USED AND FOLLOW YOUR EMPLOYER'S SAFETY PRACTICES.

SE RECOMIENDA LEER Y ENTENDER LAS INSTRUCCIONES DEL FABRICANTE PARA EL USO DE ESTE EQUIPO Y LOS CONSUMIBLES QUE VA A UTILIZAR, SIGA LAS MEDIDAS DE SEGURIDAD DE SU SUPERVISOR.

LISEZ ET COMPRENEZ LES INSTRUCTIONS DU FABRICANT EN CE QUI REGARDE CET EQUIPMENT ET LES PRODUITS A ETRE EMPLOYES ET SUIVEZ LES PROCEDURES DE SECURITE DE VOTRE EMPLOYEUR.

LESEN SIE UND BEFOLGEN SIE DIE BETRIEBSANLEITUNG DER ANLAGE UND DEN ELEKTRODENEINSATZ DES HERSTELLERS. DIE UNFALLVERHÜTUNGSVORSCHRIFTEN DES ARBEITGEBERS SIND EBENFALLS ZU BEACHTEN.

			
<ul style="list-style-type: none"> ● Keep your head out of fumes. ● Use ventilation or exhaust to remove fumes from breathing zone. 	<ul style="list-style-type: none"> ● Turn power off before servicing. 	<ul style="list-style-type: none"> ● Do not operate with panel open or guards off. 	WARNING
<ul style="list-style-type: none"> ● Los humos fuera de la zona de respiración. ● Mantenga la cabeza fuera de los humos. Utilice ventilación o aspiración para gases. 	<ul style="list-style-type: none"> ● Desconectar el cable de alimentación de poder de la máquina antes de iniciar cualquier servicio. 	<ul style="list-style-type: none"> ● No operar con panel abierto o guardas quitadas. 	Spanish AVISO DE PRECAUCION
<ul style="list-style-type: none"> ● Gardez la tête à l'écart des fumées. ● Utilisez un ventilateur ou un aspirateur pour ôter les fumées des zones de travail. 	<ul style="list-style-type: none"> ● Débranchez le courant avant l'entretien. 	<ul style="list-style-type: none"> ● N'opérez pas avec les panneaux ouverts ou avec les dispositifs de protection enlevés. 	French ATTENTION
<ul style="list-style-type: none"> ● Vermeiden Sie das Einatmen von Schweißrauch! ● Sorgen Sie für gute Be- und Entlüftung des Arbeitsplatzes! 	<ul style="list-style-type: none"> ● Strom vor Wartungsarbeiten abschalten! (Netzstrom völlig öffnen; Maschine anhalten!) 	<ul style="list-style-type: none"> ● Anlage nie ohne Schutzgehäuse oder Innenschutzverkleidung in Betrieb setzen! 	German WARNUNG
<ul style="list-style-type: none"> ● Mantenha seu rosto da fumaça. ● Use ventilação e exaustão para remover fumo da zona respiratória. 	<ul style="list-style-type: none"> ● Não opere com as tampas removidas. ● Desligue a corrente antes de fazer serviço. ● Não toque as partes elétricas nuas. 	<ul style="list-style-type: none"> ● Mantenha-se afastado das partes moventes. ● Não opere com os painéis abertos ou guardas removidas. 	Portuguese ATENÇÃO
<ul style="list-style-type: none"> ● ヒュームから頭を離すようにして下さい。 ● 換気や排煙に十分留意して下さい。 	<ul style="list-style-type: none"> ● メンテナンス・サービスに取りかかる際には、まず電源スイッチを必ず切って下さい。 	<ul style="list-style-type: none"> ● パネルやカバーを取り外したままで機械操作をしないで下さい。 	Japanese 注意事項
<ul style="list-style-type: none"> ● 頭部遠離煙霧。 ● 在呼吸區使用通風或排風器除煙。 	<ul style="list-style-type: none"> ● 維修前切斷電源。 	<ul style="list-style-type: none"> ● 儀表板打開或沒有安全罩時不準作業。 	Chinese 警告
<ul style="list-style-type: none"> ● 얼굴로부터 용접가스를 멀리하십시오. ● 호흡지역으로부터 용접가스를 제거하기 위해 가스제거기나 통풍기를 사용하십시오. 	<ul style="list-style-type: none"> ● 보수전에 전원을 차단하십시오. 	<ul style="list-style-type: none"> ● 판넬이 열린 상태로 작동치 마십시오. 	Korean 위험
<ul style="list-style-type: none"> ● بعد رأسك بعيداً عن الدخان. ● استعمل التهوية أو جهاز ضغط الدخان للخارج لكي تبعد الدخان عن المنطقة التي تتنفس فيها. 	<ul style="list-style-type: none"> ● أقطع التيار الكهربائي قبل القيام بأية صيانة. 	<ul style="list-style-type: none"> ● لا تشغيل هذا الجهاز إذا كانت الاغطية الحديدية الواقية ليست عليه. 	Arabic تحذير

LEIA E COMPREENDA AS INSTRUÇÕES DO FABRICANTE PARA ESTE EQUIPAMENTO E AS PARTES DE USO, E SIGA AS PRÁTICAS DE SEGURANÇA DO EMPREGADOR.

使う機械や溶材のメーカーの指示書をよく読み、まず理解して下さい。そして貴社の安全規定に従って下さい。

請詳細閱讀並理解製造廠提供的說明以及應該使用的銀焊材料，並請遵守貴方的有關勞動保護規定。

이 제품에 동봉된 작업지침서를 숙지하시고 귀사의 작업자 안전수칙을 준수하시기 바랍니다.

اقرأ بتمعن وافهم تعليمات المصنع المنتج لهذه المعدات والمواد قبل استعمالها واتبع تعليمات الوقاية لصاحب العمل.



• World's Leader in Welding and Cutting Products •

• Sales and Service through Subsidiaries and Distributors Worldwide •

Cleveland, Ohio 44117-1199 U.S.A. TEL: 216.481.8100 FAX: 216.486.1751 WEB SITE: www.lincolnelectric.com