

For use with machines having code Numbers: **70301 & 70300**

Safety Depends on You

Lincoln arc welding and cutting equipment is designed and built with safety in mind. However, your overall safety can be increased by proper installation ... and thoughtful operation on your part. **DO NOT INSTALL, OPERATE OR REPAIR THIS EQUIPMENT WITHOUT READING THIS MANUAL, AND THE SAETY PRECAUTIONS CONTAINED THROUGHOUT.** And, most importantly, think before you act and be careful.

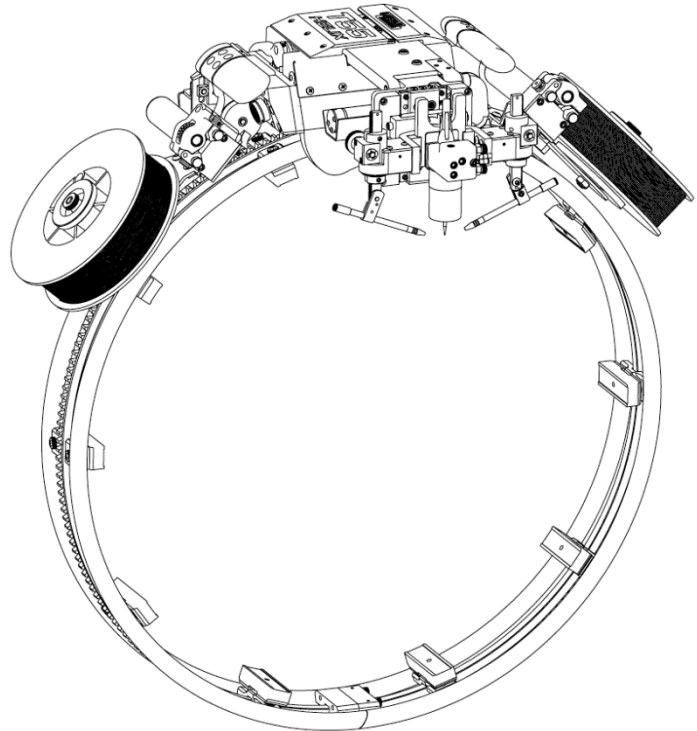

OPERATOR'S MANUAL



Copyright © Lincoln Global Inc.

WARNING

CALIFORNIA PROPOSITION 65 WARNINGS

Diesel engine exhaust and some of its constituents are known to the State of California to cause cancer, birth defects, and other reproductive harm.

The Above For Diesel Engines

The engine exhaust from this product contains chemicals known to the State of California to cause cancer, birth defects, or other reproductive harm.

The Above For Gasoline Engines

ARC WELDING CAN BE HAZARDOUS. PROTECT YOURSELF AND OTHERS FROM POSSIBLE SERIOUS INJURY OR DEATH. KEEP CHILDREN AWAY. PACEMAKER WEARERS SHOULD CONSULT WITH THEIR DOCTOR BEFORE OPERATING.

Read and understand the following safety highlights. For additional safety information, it is strongly recommended that you purchase a copy of "Safety in Welding & Cutting - ANSI Standard Z49.1" from the American Welding Society, P.O. Box 351040, Miami, Florida 33135 or CSA Standard W117.2-1974. A Free copy of "Arc Welding Safety" booklet E205 is available from the Lincoln Electric Company, 22801 St. Clair Avenue, Cleveland, Ohio 44117-1199.

BE SURE THAT ALL INSTALLATION, OPERATION, MAINTENANCE AND REPAIR PROCEDURES ARE PERFORMED ONLY BY QUALIFIED INDIVIDUALS.



FOR ENGINE powered equipment.

1.a. Turn the engine off before troubleshooting and maintenance work unless the maintenance work requires it to be running.



1.b. Operate engines in open, well-ventilated areas or vent the engine exhaust fumes outdoors.



1.c. Do not add the fuel near an open flame welding arc or when the engine is running. Stop the engine and allow it to cool before refueling to prevent spilled fuel from vaporizing on contact with hot engine parts and igniting. Do not spill fuel when filling tank. If fuel is spilled, wipe it up and do not start engine until fumes have been eliminated.

1.d. Keep all equipment safety guards, covers and devices in position and in good repair. Keep hands, hair, clothing and tools away from V-belts, gears, fans and all other moving parts when starting, operating or repairing equipment.

1.e. In some cases it may be necessary to remove safety guards to perform required maintenance. Remove guards only when necessary and replace them when the maintenance requiring their removal is complete. Always use the greatest care when working near moving parts.



1.f. Do not put your hands near the engine fan. Do not attempt to override the governor or idler by pushing on the throttle control rods while the engine is running.

1.g. To prevent accidentally starting gasoline engines while turning the engine or welding generator during maintenance work, disconnect the spark plug wires, distributor cap or magneto wire as appropriate.



1.h. To avoid scalding, do not remove the radiator pressure cap when the engine is hot.



ELECTRIC AND MAGNETIC FIELDS may be dangerous

2.a. Electric current flowing through any conductor causes localized Electric and Magnetic Fields (EMF). Welding current creates EMF fields around welding cables and welding machines

2.b. EMF fields may interfere with some pacemakers, and welders having a pacemaker should consult their physician before welding.

2.c. Exposure to EMF fields in welding may have other health effects which are now not known.

2.d. All welders should use the following procedures in order to minimize exposure to EMF fields from the welding circuit:

2.d.1. Route the electrode and work cables together - Secure them with tape when possible.

2.d.2. Never coil the electrode lead around your body.

2.d.3. Do not place your body between the electrode and work cables. If the electrode cable is on your right side, the work cable should also be on your right side.

2.d.4. Connect the work cable to the workpiece as close as possible to the area being welded.

2.d.5. Do not work next to welding power source.



ELECTRIC SHOCK can kill.

- 3.a. The electrode and work (or ground) circuits are electrically "hot" when the welder is on. Do not touch these "hot" parts with your bare skin or wet clothing. Wear dry, hole-free gloves to insulate hands.
- 3.b. Insulate yourself from work and ground using dry insulation. Make certain the insulation is large enough to cover your full area of physical contact with work and ground.

In addition to the normal safety precautions, if welding must be performed under electrically hazardous conditions (in damp locations or while wearing wet clothing; on metal structures such as floors, gratings or scaffolds; when in cramped positions such as sitting, kneeling or lying, if there is a high risk of unavoidable or accidental contact with the workpiece or ground) use the following equipment:

- Semiautomatic DC Constant Voltage (Wire) Welder.
 - DC Manual (Stick) Welder.
 - AC Welder with Reduced Voltage Control.
- 3.c. In semiautomatic or automatic wire welding, the electrode, electrode reel, welding head, nozzle or semiautomatic welding gun are also electrically "hot".
- 3.d. Always be sure the work cable makes a good electrical connection with the metal being welded. The connection should be as close as possible to the area being welded.
- 3.e. Ground the work or metal to be welded to a good electrical (earth) ground.
- 3.f. Maintain the electrode holder, work clamp, welding cable and welding machine in good, safe operating condition. Replace damaged insulation.
- 3.g. Never dip the electrode in water for cooling.
- 3.h. Never simultaneously touch electrically "hot" parts of electrode holders connected to two welders because voltage between the two can be the total of the open circuit voltage of both welders.
- 3.i. When working above floor level, use a safety belt to protect yourself from a fall should you get a shock.
- 3.j. Also see Items 6.c. and 8.



ARC RAYS can burn.

- 4.a. Use a shield with the proper filter and cover plates to protect your eyes from sparks and the rays of the arc when welding or observing open arc welding. Headshield and filter lens should conform to ANSI Z87.1 standards.
- 4.b. Use suitable clothing made from durable flame-resistant material to protect your skin and that of your helpers from the arc rays.
- 4.c. Protect other nearby personnel with suitable, non-flammable screening and/or warn them not to watch the arc nor expose themselves to the arc rays or to hot spatter or metal.



FUMES AND GASES can be dangerous.

- 5.a. Welding may produce fumes and gases hazardous to health. Avoid breathing these fumes and gases. When welding, keep your head out of the fume. Use enough ventilation and/or exhaust at the arc to keep fumes and gases away from the breathing zone. **When welding with electrodes which require special ventilation such as stainless or hard facing (see instructions on container or MSDS) or on lead or cadmium plated steel and other metals or coatings which produce highly toxic fumes, keep exposure as low as possible and within applicable OSHA PEL and ACGIH TLV limits using local exhaust or mechanical ventilation. In confined spaces or in some circumstances, outdoors, a respirator may be required. Additional precautions are also required when welding on galvanized steel.**
5. b. The operation of welding fume control equipment is affected by various factors including proper use and positioning of the equipment, maintenance of the equipment and the specific welding procedure and application involved. Worker exposure level should be checked upon installation and periodically thereafter to be certain it is within applicable OSHA PEL and ACGIH TLV limits.
- 5.c. Do not weld in locations near chlorinated hydrocarbon vapors coming from degreasing, cleaning or spraying operations. The heat and rays of the arc can react with solvent vapors to form phosgene, a highly toxic gas, and other irritating products.
- 5.d. Shielding gases used for arc welding can displace air and cause injury or death. Always use enough ventilation, especially in confined areas, to insure breathing air is safe.
- 5.e. Read and understand the manufacturer's instructions for this equipment and the consumables to be used, including the material safety data sheet (MSDS) and follow your employer's safety practices. MSDS forms are available from your welding distributor or from the manufacturer.
- 5.f. Also see item 1.b.



WELDING and CUTTING SPARKS can cause fire or explosion.

6.a. Remove fire hazards from the welding area. If this is not possible, cover them to prevent the welding sparks from starting a fire.

Remember that welding sparks and hot materials from welding can easily go through small cracks and openings to adjacent areas. Avoid welding near hydraulic lines. Have a fire extinguisher readily available.

- 6.b. Where compressed gases are to be used at the job site, special precautions should be used to prevent hazardous situations. Refer to "Safety in Welding and Cutting" (ANSI Standard Z49.1) and the operating information for the equipment being used.
- 6.c. When not welding, make certain no part of the electrode circuit is touching the work or ground. Accidental contact can cause overheating and create a fire hazard.
- 6.d. Do not heat, cut or weld tanks, drums or containers until the proper steps have been taken to insure that such procedures will not cause flammable or toxic vapors from substances inside. They can cause an explosion even though they have been "cleaned". For information, purchase "Recommended Safe Practices for the Preparation for Welding and Cutting of Containers and Piping That Have Held Hazardous Substances", AWS F4.1 from the American Welding Society (see address above).
- 6.e. Vent hollow castings or containers before heating, cutting or welding. They may explode.
- 6.f. Sparks and spatter are thrown from the welding arc. Wear oil free protective garments such as leather gloves, heavy shirt, cuffless trousers, high shoes and a cap over your hair. Wear ear plugs when welding out of position or in confined places. Always wear safety glasses with side shields when in a welding area.
- 6.g. Connect the work cable to the work as close to the welding area as practical. Work cables connected to the building framework or other locations away from the welding area increase the possibility of the welding current passing through lifting chains, crane cables or other alternate circuits. This can create fire hazards or overheat lifting chains or cables until they fail.
- 6.h. Also see item 1.c.
- 6.i. Read and follow NFPA 51B "Standard for Fire Prevention During Welding, Cutting and Other Hot Work", available from NFPA, 1 Batterymarch Park, PO box 9101, Quincy, Ma 022690-9101.
- 6.j. Do not use a welding power source for pipe thawing.



CYLINDER may explode if damaged.

7.a. Use only compressed gas cylinders containing the correct shielding gas for the process used and properly operating regulators designed for the gas and pressure used. All hoses, fittings, etc. should be suitable for the application and maintained in good condition.

- 7.b. Always keep cylinders in an upright position securely chained to an undercarriage or fixed support.
- 7.c. Cylinders should be located:
 - Away from areas where they may be struck or subjected to physical damage.
 - A safe distance from arc welding or cutting operations and any other source of heat, sparks, or flame.
- 7.d. Never allow the electrode, electrode holder or any other electrically "hot" parts to touch a cylinder.
- 7.e. Keep your head and face away from the cylinder valve outlet when opening the cylinder valve.
- 7.f. Valve protection caps should always be in place and hand tight except when the cylinder is in use or connected for use.
- 7.g. Read and follow the instructions on compressed gas cylinders, associated equipment, and CGA publication P-1, "Precautions for Safe Handling of Compressed Gases in Cylinders," available from the Compressed Gas Association 1235 Jefferson Davis Highway, Arlington, VA 22202.



FOR ELECTRICALLY powered equipment.

- 8.a. Turn off input power using the disconnect switch at the fuse box before working on the equipment.
- 8.b. Install equipment in accordance with the U.S. National Electrical Code, all local codes and the manufacturer's recommendations.
- 8.c. Ground the equipment in accordance with the U.S. National Electrical Code and the manufacturer's recommendations.

Refer to <http://www.lincolnelectric.com/safety> for additional safety information.

PRÉCAUTIONS DE SÛRETÉ

Pour votre propre protection lire et observer toutes les instructions et les précautions de sûreté spécifiques qui paraissent dans ce manuel aussi bien que les précautions de sûreté générales suivantes:

Sûreté Pour Soudage A L'Arc

1. Protégez-vous contre la secousse électrique:
 - a. Les circuits à l'électrode et à la pièce sont sous tension quand la machine à souder est en marche. Eviter toujours tout contact entre les parties sous tension et la peau nue ou les vêtements mouillés. Porter des gants secs et sans trous pour isoler les mains.
 - b. Faire très attention de bien s'isoler de la masse quand on soude dans des endroits humides, ou sur un plancher métallique ou des grilles métalliques, principalement dans les positions assis ou couché pour lesquelles une grande partie du corps peut être en contact avec la masse.
 - c. Maintenir le porte-électrode, la pince de masse, le câble de soudage et la machine à souder en bon et sûr état de fonctionnement.
 - d. Ne jamais plonger le porte-électrode dans l'eau pour le refroidir.
 - e. Ne jamais toucher simultanément les parties sous tension des porte-électrodes connectés à deux machines à souder parce que la tension entre les deux pinces peut être le total de la tension à vide des deux machines.
 - f. Si on utilise la machine à souder comme une source de courant pour soudage semi-automatique, ces précautions pour le porte-électrode s'appliquent aussi au pistolet de soudage.
2. Dans le cas de travail au dessus du niveau du sol, se protéger contre les chutes dans le cas où on reçoit un choc. Ne jamais enrouler le câble-électrode autour de n'importe quelle partie du corps.
3. Un coup d'arc peut être plus sévère qu'un coup de soliel, donc:
 - a. Utiliser un bon masque avec un verre filtrant approprié ainsi qu'un verre blanc afin de se protéger les yeux du rayonnement de l'arc et des projections quand on soude ou quand on regarde l'arc.
 - b. Porter des vêtements convenables afin de protéger la peau de soudeur et des aides contre le rayonnement de l'arc.
 - c. Protéger l'autre personnel travaillant à proximité au soudage à l'aide d'écrans appropriés et non-inflammables.
4. Des gouttes de laitier en fusion sont émises de l'arc de soudage. Se protéger avec des vêtements de protection libres de l'huile, tels que les gants en cuir, chemise épaisse, pantalons sans revers, et chaussures montantes.

5. Toujours porter des lunettes de sécurité dans la zone de soudage. Utiliser des lunettes avec écrans latéraux dans les zones où l'on pique le laitier.
6. Eloigner les matériaux inflammables ou les recouvrir afin de prévenir tout risque d'incendie dû aux étincelles.
7. Quand on ne soude pas, poser la pince à un endroit isolé de la masse. Un court-circuit accidentel peut provoquer un échauffement et un risque d'incendie.
8. S'assurer que la masse est connectée le plus près possible de la zone de travail qu'il est pratique de le faire. Si on place la masse sur la charpente de la construction ou d'autres endroits éloignés de la zone de travail, on augmente le risque de voir passer le courant de soudage par les chaînes de levage, câbles de grue, ou autres circuits. Cela peut provoquer des risques d'incendie ou d'échauffement des chaînes et des câbles jusqu'à ce qu'ils se rompent.
9. Assurer une ventilation suffisante dans la zone de soudage. Ceci est particulièrement important pour le soudage de tôles galvanisées plombées, ou cadmiées ou tout autre métal qui produit des fumées toxiques.
10. Ne pas souder en présence de vapeurs de chlore provenant d'opérations de dégraissage, nettoyage ou pistolage. La chaleur ou les rayons de l'arc peuvent réagir avec les vapeurs du solvant pour produire du phosgène (gas fortement toxique) ou autres produits irritants.
11. Pour obtenir de plus amples renseignements sur la sûreté, voir le code "Code for safety in welding and cutting" CSA Standard W 117.2-1974.

PRÉCAUTIONS DE SÛRETÉ POUR LES MACHINES À SOUDER À TRANSFORMATEUR ET À REDRESSEUR

1. Relier à la terre le châssis du poste conformément au code de l'électricité et aux recommandations du fabricant. Le dispositif de montage ou la pièce à souder doit être branché à une bonne mise à la terre.
2. Autant que possible, l'installation et l'entretien du poste seront effectués par un électricien qualifié.
3. Avant de faire des travaux à l'intérieur de poste, le débrancher à l'interrupteur à la boîte de fusibles.
4. Garder tous les couvercles et dispositifs de sûreté à leur place.

Thank You —

for selecting a **QUALITY** product by Lincoln Electric. We want you to take pride in operating this Lincoln Electric Company product
••• as much pride as we have in bringing this product to you!

CUSTOMER ASSISTANCE POLICY

The business of The Lincoln Electric Company is manufacturing and selling high quality welding equipment, consumables, and cutting equipment. Our challenge is to meet the needs of our customers and to exceed their expectations. On occasion, purchasers may ask Lincoln Electric for advice or information about their use of our products. We respond to our customers based on the best information in our possession at that time. Lincoln Electric is not in a position to warrant or guarantee such advice, and assumes no liability, with respect to such information or advice. We expressly disclaim any warranty of any kind, including any warranty of fitness for any customer's particular purpose, with respect to such information or advice. As a matter of practical consideration, we also cannot assume any responsibility for updating or correcting any such information or advice once it has been given, nor does the provision of information or advice create, expand or alter any warranty with respect to the sale of our products.

Lincoln Electric is a responsive manufacturer, but the selection and use of specific products sold by Lincoln Electric is solely within the control of, and remains the sole responsibility of the customer. Many variables beyond the control of Lincoln Electric affect the results obtained in applying these types of fabrication methods and service requirements.

Subject to Change – This information is accurate to the best of our knowledge at the time of printing. Please refer to www.lincolnelectric.com for any updated information.

Please Examine Carton and Equipment For Damage Immediately

When this equipment is shipped, title passes to the purchaser upon receipt by the carrier. Consequently, Claims for material damaged in shipment must be made by the purchaser against the transportation company at the time the shipment is received.

Please record your equipment identification information below for future reference. This information can be found on your machine nameplate.

Product _____

Model Number _____

Code Number or Date Code _____

Serial Number _____

Date Purchased _____

Where Purchased _____

Whenever you request replacement parts or information on this equipment, always supply the information you have recorded above. The code number is especially important when identifying the correct replacement parts.

On-Line Product Registration

- Register your machine with Lincoln Electric either via fax or over the Internet.

- For faxing: Complete the form on the back of the warranty statement included in the literature packet accompanying this machine and fax the form per the instructions printed on it.
- For On-Line Registration: Go to our **WEB SITE at www.lincolnelectric.com**. Choose "Support" and then "Register Your Product". Please complete the form and submit your registration.

Read this Operators Manual completely before attempting to use this equipment. Save this manual and keep it handy for quick reference. Pay particular attention to the safety instructions we have provided for your protection. The level of seriousness to be applied to each is explained below:

WARNING

This statement appears where the information **must** be followed **exactly** to avoid **serious personal injury or loss of life**.

CAUTION

This statement appears where the information **must** be followed to avoid **minor personal injury or damage to this equipment**.

TABLE OF CONTENTS

TABLE OF CONTENTS

TABLE OF CONTENTS	i	T55 Weld Head	17
TABLE OF FIGURES.....	ii	Daily Maintenance	17
BASIC INFORMATION.....	1	Weekly Maintenance	17
Toolbox.....	1	Monthly Maintenance	17
Technical Specifications	2	Quarterly Maintenance.....	17
Track Ring	3	PARTS LIST.....	20
Shoe Placement.....	4	Index	37
Shoe Extension	4		
Track Ring Installation	5		
Weld Head	8		
Weld Head Installation	8		
Torch Setup.....	9		
Fillet Weld Angle	9		
Lead Lag Angle	9		
Torch Stick Out.....	9		
Tungsten Stick Out	10		
Torch Height.....	10		
Wire Feeder Angle.....	11		
Verify Drive Rolls	12		
Change Upper Drive Roll	12		
Change Lower Drive Roll.....	13		
Wire Feed Setup	14		
Wire Spool Installation	14		
Feeding the Wire.....	14		
Adjustments for Radial Clearance	15		
OPERATION.....	16		
MAINTENANCE	17		
Preventative Maintenance Schedule	17		
Track Ring	17		
Monthly Maintenance	17		
Quarterly Maintenance	17		
Annual Maintenance	17		

TABLE OF CONTENTS

TABLE OF FIGURES

Figure 1 – TRACK RING.....	3
Figure 2 – SHOE PLACEMENT	4
Figure 3 – SHOE EXTENSION	5
Figure 4 – ASSEMBLY STEP 1	5
Figure 5 – ASSEMBLY STEP 2	6
Figure 6 – ASSEMBLY STEP 3	6
Figure 7 – TRACK DISTANCE.....	6
Figure 8 – TRACK PLACEMENT	7
Figure 9 – WELD HEAD	8
Figure 10 – LATCH AND KNOB.....	8
Figure 11 – FILLET WELD ANGLE	9
Figure 12 – FILLET WELD ANGLE 2	9
Figure 13 – TORCH LEAD/LAG	9
Figure 14 – LEAD/LAG ADJUSTMENT.....	9
Figure 15 – TORCH STICK-OUT	10
Figure 16 – BACK CAP	10
Figure 17 – SLIDE CLAMP BOLTS	10
Figure 18 – TORCH HEAD REMOVAL	10
Figure 19 – AVC PLATE	11
Figure 20 – WIRE GUIDE HEIGHT	11
Figure 21 – WIRE GUIDE ADJUST	11
Figure 22 – LOWER DRIVE ROLL	12
Figure 23 – TENSION KNOB	12
Figure 24 – SET SCREW	12
Figure 25 – DRIVE ROLL SHAFT.....	12
Figure 26 – ROLLER SET SCREW 2	13
Figure 27 – MOTOR KEY	13
Figure 28 – HUB NUT	14
Figure 29 – THUMB NUT	14
Figure 30 – WIRE 1 INSTALLATION.....	14
Figure 31 – WIRE 2 INSTALLATION.....	14
Figure 32 – INLET GUIDE.....	15
Figure 33 – THUMB SCREW.....	15
Figure 34 – WIRE ARMS ADJUSTED	15

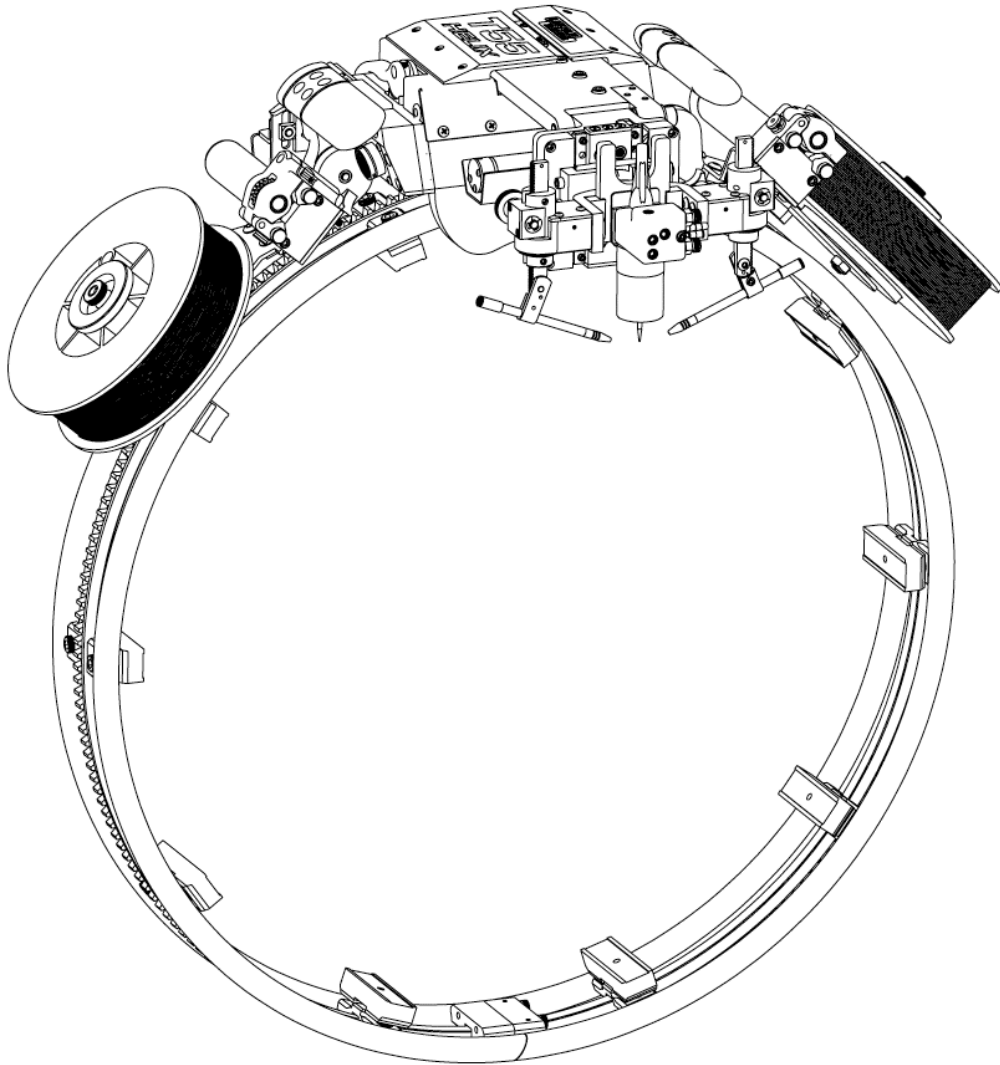

Helix™ T55

BASIC INFORMATION

The T55 Helix™ is a precision, gear driven weld head designed for GTAW (TIG) welding. Paired with the specifically designed steel and chromoly track ring, the Helix™ provides strong, reliable welds for a rugged and stable welding solution.

The T55 Helix™ tractor is controlled by a handheld controller and AVC. It features an easy release clutch which disengages the drive roll allowing free movement along the track, without removing the unit from the track ring. A heavy duty Nylon covering protects power, control, water and gas cables from wear and tear; and a high temperature Teflon coated sleeve protects the area closest to the weld head.

The standard T55 weighs in at 35 lbs., without the wire arms, and has two handles for easy carrying. Two wire arms come standard with the option to remove one of the arms for added versatility. The Weld Head has 1" of oscillation stroke allowing the operator flexibility when installing the Weld Head and Track Ring. 3.5" of AVC stroke allows the operator to weld in deep groove applications. Torch and Arc orientation can be adjusted 140° to adjust for numerous weld parameters. Precision motors allow for travel speeds from 0.5 IPM to 20 IPM.

The track ring is a low profile heavy duty track ring stabilized at even intervals with cross braces. Mounting shoes, containing spring cushions rated to 800lb, attach to the cross braces and allow for the work surface's heat expansion which stops binding and ring distortion. The geared system of the track eliminates slippage and the angled section interface prevents tractor jump.

The T55 Helix™ comes fully assembled in a rugged waterproof case along with a gas line, water in and water out, power cable, control cable, and a Helix™ tool box.

Toolbox

Included with the Helix™ is a toolbox of common tools and consumables. These tools are for general operation and maintenance; more in-depth maintenance may require additional tools.

Tools

60" Flexible cloth Measuring tape
 7/64" Hex Key (wire guide clamp)
 1/8" Hex Key (wire guide angle adjust)
 3/16" Hex Key (Oscillation plate, Lead/Lag Angle)
 1/4" Hex Key (track shoes)
 5/16" Hex Key (Weld Angle)
 5/32" Hex Key (track clamp bolts, barrel clamp, torch slide)
 Wire Cutters

Consumables

Pyrex Cup (2)
 1/8 Tungsten adapter (2)
 Collet Body
 1/8 Collet (2)
 1/8 Tungsten (3)
 Back Cap Long
 Back Cap Medium

Optional Consumables not included

5/32 Tungsten Adapter
 5/32 Collet
 5/32 Tungsten

Technical Specifications

Product		Helix™ T55 Tractor	
Product Number		K52002-1	
Input Power	25V DC		
Travel Speed	0.5 – 20 ipm		
Wire Feed Speed	0.1 to 130 ipm		
Wire Size Range	0.030 - .052		
Radial Clearance	5.5 in (139.7 mm)		
Axial Clearance	11.5 in (292.1 mm)		
Oscillation Stroke	1 in (25.4 mm)		
Arc Voltage Control (AVC) Stroke*	3.5 in (88.9 mm) AVC can be manually offset 3"		
Net Weight	57 lb with cables (25.86 kg)		
Track to Rear	3.41 in (86.6 mm)		
Track to Electrode (Min – Max)	Minimum: 5.03 in (128 mm) - Maximum: 10.64 in (270.4 mm) with standard 6 in (152.4 mm) OSC plate Optional 12" and 24" plates are available.		
Electrode to Front	1.93 in (49 mm)		
Lead/Lag*	360°		
Torch tilt in*	30° maximum		
Torch tilt out*	110° maximum		
Manual Torch Height Adjustment*	±0.9 in (23 mm)		
*See Pages 9-10 for adjustment instructions			

Product		Helix™ Track Ring	
Product Number		K52000-XX (Where XX is equal to the track size)	
Track to Work Surface	Minimum	Inside of Track .67"	Outside of Track 1.42"
	Nominal	Inside of Track .80"	Outside of Track 1.55"
	Maximum	Inside of Track 1.19"	Outside of Track 1.94"
Track Width	3.90 in (99.1)		

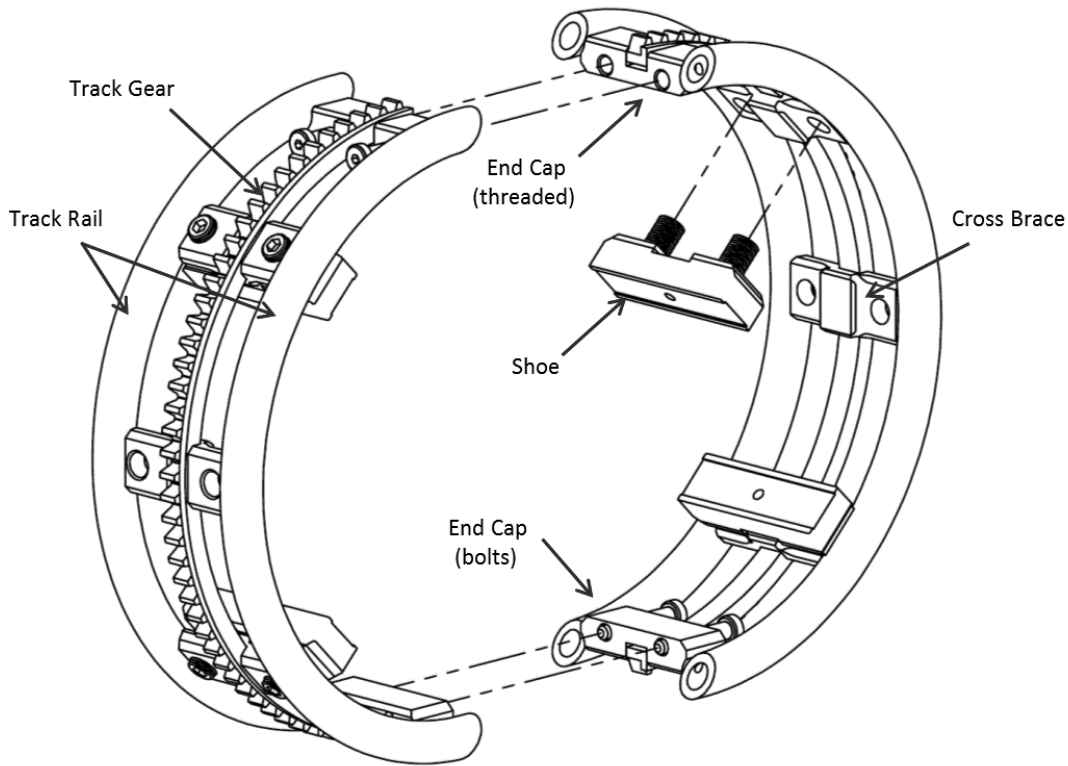

FIGURE 1 – TRACK RING

Track Ring

Standard track rings come in two varieties. Two segment tracks and four segment tracks. Two segment tracks start at an 8 inch diameter and increase in size by 2 inch increments up to 28 inches. Four segment tracks start at 30 inches and increase in size by 4 inch increments up to 64 inches. Special sizes are available upon request.

Each segment will have 2 end caps; one threaded one with bolts.

Track rings will have cross braces evenly distributed between the end caps. The number of cross braces per segment is determined by the size of the track ring:

- 8" track rings have 3 cross braces
6 per track ring
- 10"-32" track rings have 5 cross braces
10 per track ring
- 32" and above sizes will vary

NOTE



Not all cross braces require shoes.

Track shoes come already installed on the track ring (see Figure 2 – Shoe Placement). Figure 2 is an example of a 2 segment track ring.

Pipe dimensions vary by size, type and application. A 12" track rings is designed for a 12" outside diameter pipe.

Do not use different serial number track rings of the same size.

NOTE



Track rings are serialized by size and engineered to fit together, Tracks of the same serial number only join the correct way.

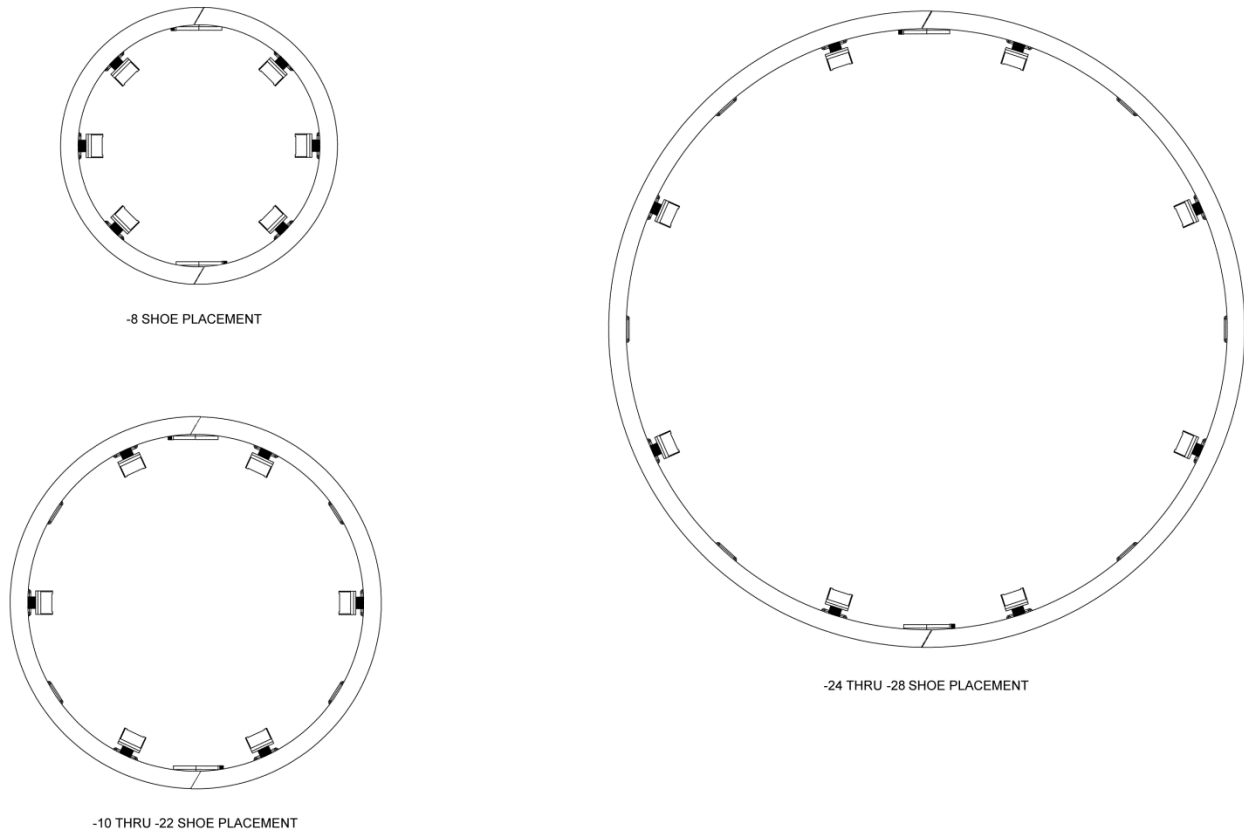

FIGURE 2 – SHOE PLACEMENT

Shoe Placement

The number of track shoes is determined by the size of the track ring:

- 8"-22" track rings have 6 track shoes
- 24-32" track rings have 8 track shoes

Track shoes screw into the cross braces using a 1/4 inch Hex Key. Turn counterclockwise to attach track shoe to track ring.

8" track rings require a track shoe on every cross brace. 10"-28" track rings will have a shoe starting on the cross brace nearest the end caps and continuing on every other cross brace per segment (see Figure 2 – Shoe Placement).

Thread track shoes onto cross braces using 2 to 3 turns per bolt then switch to the next bolt on the same shoe. Ensure that the track shoe stays even, tighten until a minimum of 5 threads are engaged for each bolt. Repeat process with every track shoe.

Shoe Extension

In order to accommodate different size pipes, extensions are available. These extensions attach onto the track shoes and are stackable to adjust for various size pipes.

Extension sizes are in 1/2", 1", 2", and 3" increments. Screws are provided for the extension sizes. Stacking extensions creates a unique size and will require the user to purchase their own .25x20 Socket Head Cap Screw for the particular stacked length.

Part numbers for the Extensions are as follows:

- | | |
|-------|-----------|
| • .5" | K52060-05 |
| • 1" | K52060-10 |
| • 2" | K52060-20 |
| • 3" | K52060-30 |

NOTE



Adding extensions decreases the actual travel speed at the Weld. Calibration may be required.

Shoe extension bolts pass through the shoe extension and thread into the track shoe to keep the extension firmly in place (see Figure 3 – Shoe Extension).

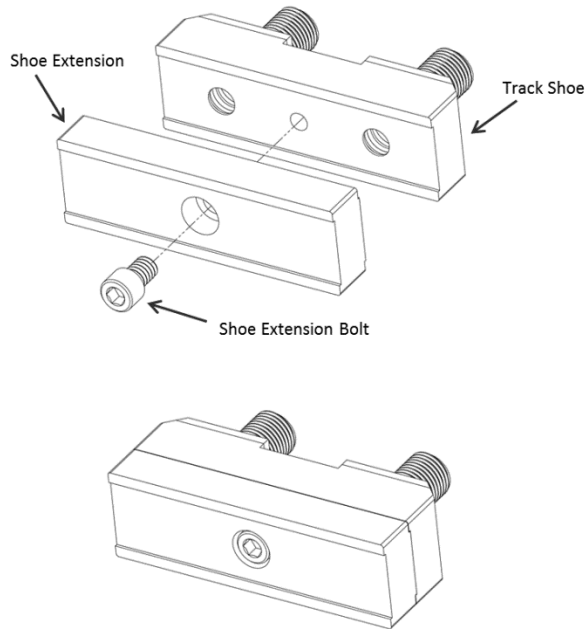

FIGURE 3 – SHOE EXTENSION

Track Ring Installation

If the track rings are assembled, separate the 2 halves of the track ring by unscrewing the 2 clamping screws at each end cap with a 5/32" hex key. For 4 segment tracks, separate into 2 halves leaving 2 segments joined for each half.

NOTE



Four segment track rings can be broken down into four individual segments for easy shipping and storage.

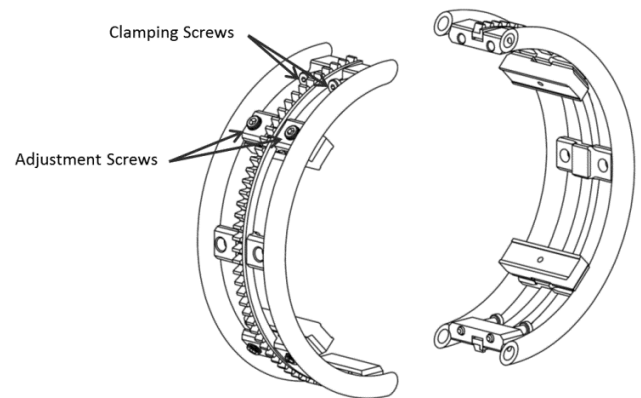

FIGURE 4 – ASSEMBLY STEP 1

1. After separating into two segments, retract each shoe completely by turning both adjustment screws (see Figure 4 – Assembly Step 1) evenly with a 1/4" hex key until the shoe is flush with the cross brace. Do not over tighten.
2. Place one half of the track ring over the work surface with the threaded end nearer the top. Slide the track over the pipe angled with more of the track over the top of the pipe, so that the weight of the track is supported (see Figure 5 – Assembly Step 2).

NOTE



Verify that the track ring is supported and will not fall before moving on to Step 3.

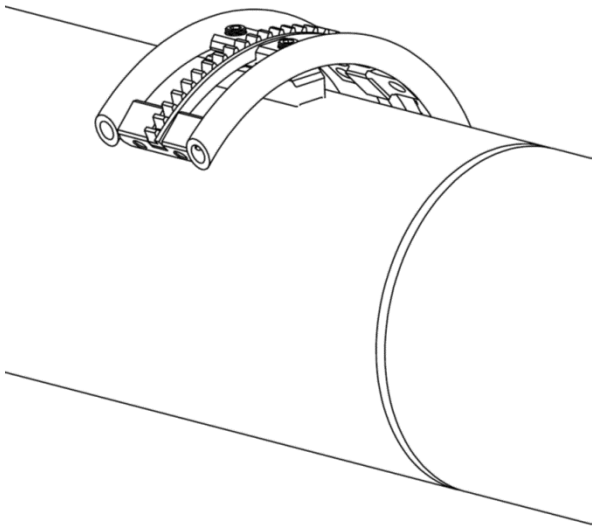

FIGURE 5 – ASSEMBLY STEP 2

3. Bring the second half of the track ring up to the pipe and secure the topmost joint by inserting and tightening the clamping screws through the tapped end cap into the threaded end cap (see Figure 6 - Assembly Step 3).

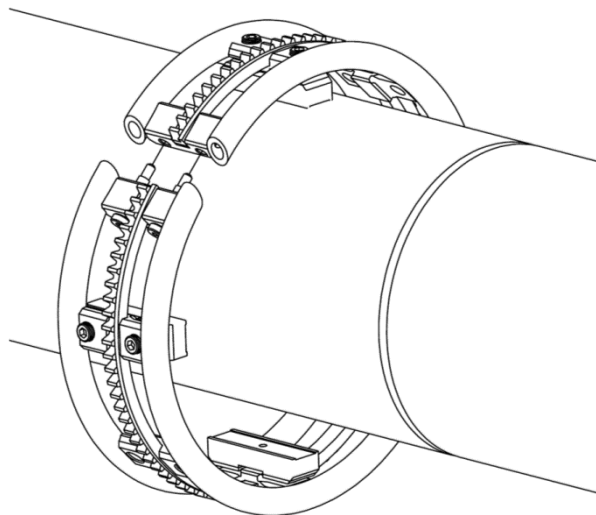

FIGURE 6 – ASSEMBLY STEP 3

4. Rotate the track ring around the pipe until you have access to the second joint. Secure this joint by tightening both clamping screws. It is normal to have a small gap at

the joints between the tubular track sections.

5. Ensure that track moves freely around the work surface. If the track does not move freely verify that all track shoes are backed against the cross brace. If the track shoes are all backed against the cross brace and there is not free movement it may be necessary to use the next larger size track ring.

NOTE



See Technical Specification on page 2 for nominal distance from track to work surface.

6. Position the track ring the desired distance from the weld joint (see Figure 7 – Track Distance). This distance will typically be between 5 and 9 inches (130 – 230 mm).

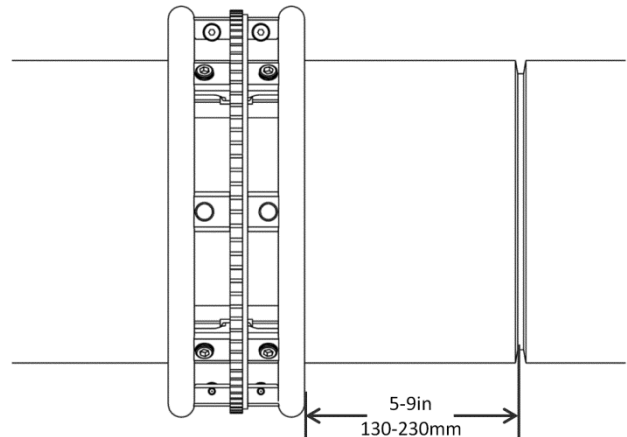

FIGURE 7 – TRACK DISTANCE

7. Rotate the track ring so that the middle of any segment is at the topmost point of the work surface which will position one track shoe at the top most point and one track shoe for the second segment at the bottom most point (see Figure 8 – Track Placement).

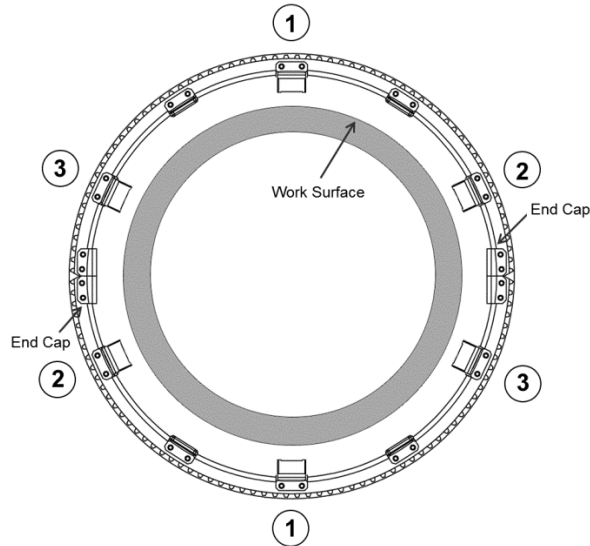

FIGURE 8 – TRACK PLACEMENT

8. Adjust shoes to center the track around the pipe by turning both adjustment screws on each shoe evenly. Start by adjusting only the top most and bottom most shoes to center the track. Once those shoes are firmly onto the work surface move on to opposing track shoes. Be sure to only tighten opposing shoes in order to keep the track centered. Repeat until all shoes are secured firmly to the work surface.

Figure 8 shows the order to tighten the track shoes. Start with the top and bottom shoes labeled “1”. Next move on to the opposing shoes labeled “2”. Lastly tighten the remaining shoes labeled “3”.

NOTE



The shoes only need to be adjusted tight enough so that the track ring is not loose. Over-tightening the adjustment screws will cause the shoes to lose their ability to accommodate pipe expansion.

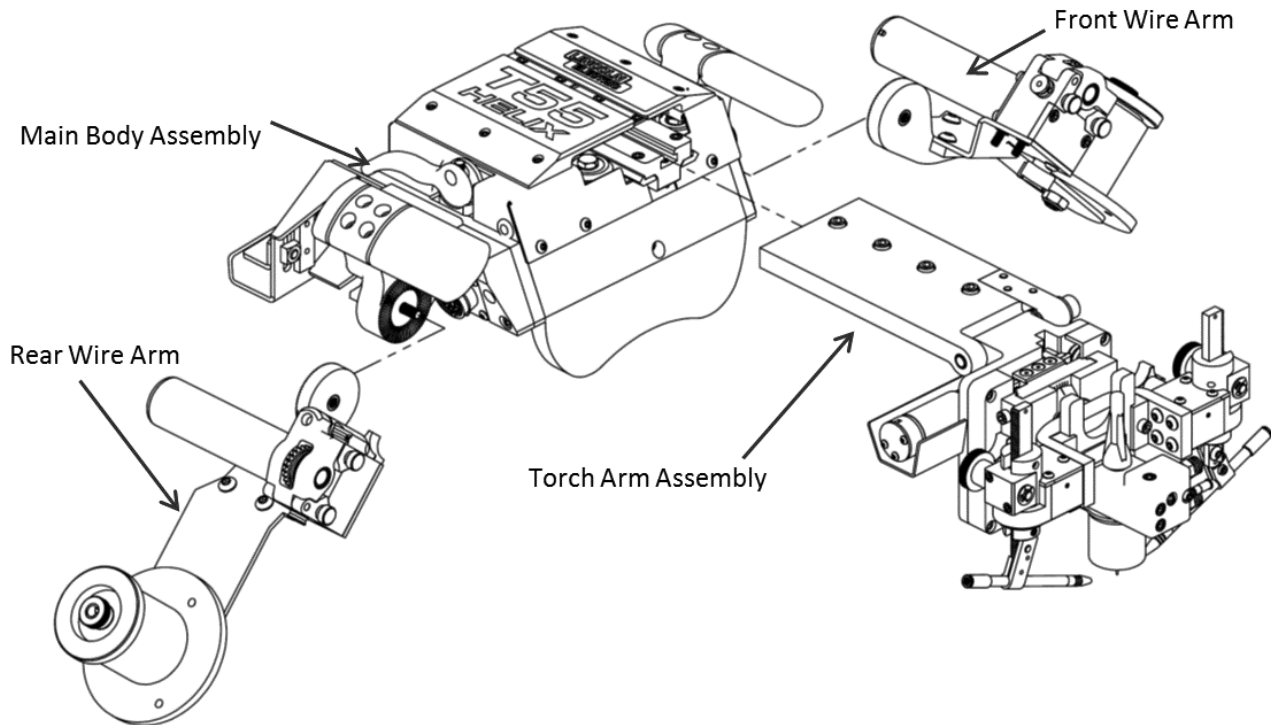

FIGURE 9 – WELD HEAD

Weld Head

This section covers weld head installation and set-up. For operational instructions and calibration refer to control system manual.

Weld Head Installation

1. Turn the clamping knob counter clockwise until the track rollers are fully separated. Ensure that the clutch latch is in the disengaged (up) position.

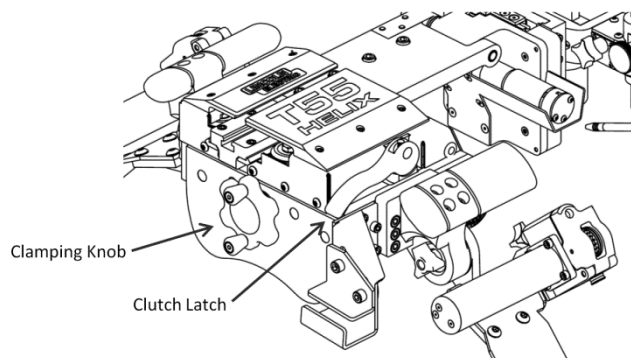

FIGURE 10 – LATCH AND KNOB

2. Lift up the tractor by the handles (not the wire feed motors), place the tractor on top of the track with the torch perpendicular to the track.
3. Turn the clamping knob clockwise to close the tractor onto the rails, ensure the weld head is secure but still loose enough to move fluidly. Over-tightening the clamping knob can result in a small jerk during the transition over the track joint, as well as excess motor stress.
4. Roll the tractor to the desired starting position on the track and engage the clutch latch.
5. Verify that there is no side to side or forward/backward motion before beginning the weld. Side to Side motion can be adjusted out by tightening the Clamping knob. Forward and back motion can be adjusted out by turning the clutch latch clockwise. Do not over-tighten.

Torch Setup

Before welding ensure the torch is set up for optimal weld parameters. There are six adjustments that can be set:

- Fillet Weld Angle
- Lead/Lag Angle
- Torch Stick Out
- Tungsten Stick Out
- Torch Height
- Wire Guides

Fillet Weld Angle

Before adjusting the Fillet Weld Angle hold firmly onto the weld head to prevent damage. To set the fillet weld angle of the torch loosen the fillet adjustment bolt with a 5/16" hex key and set the angle as desired. Swing up and tighten the bolt to clamp the torch in place. Torch can be moved 110 degrees out and 30 degrees in.

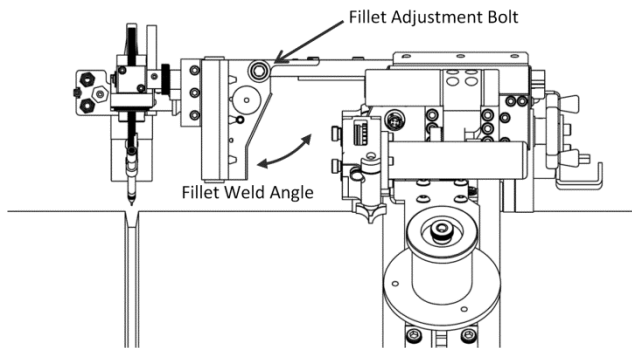

FIGURE 11 – FILLET WELD ANGLE

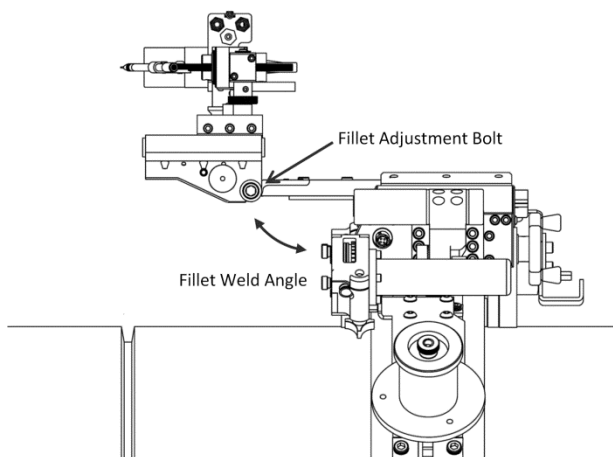

FIGURE 12 – FILLET WELD ANGLE 2

Lead Lag Angle

To set the lead/lag angle (see Figure 13 – Torch Lead/Lag) of the torch loosen the barrel clamp bolts with a 5/32" hex key on one side of the torch so that the torch is free to rotate (see Figure 14 – Lead/Lag Adjustment). Set the torch at the desired angle and tighten the barrel clamp bolts to lock it in place. There are markings in 5 degree increments to achieve the desired angle. The lead lag angle can be adjusted 360 degrees.

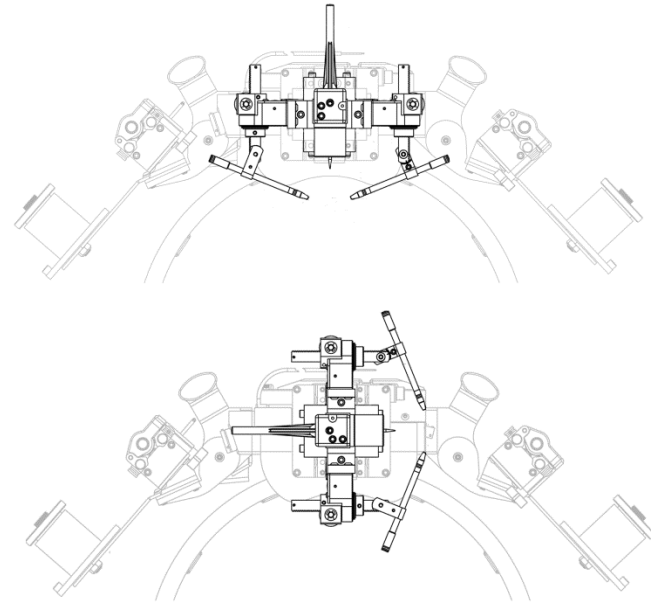

FIGURE 13 – TORCH LEAD/LAG

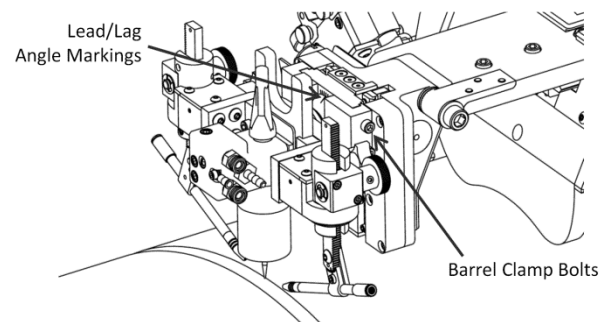

FIGURE 14 – LEAD/LAG ADJUSTMENT

Torch Stick Out

Adjust the torch stick-out after the controller has been turned on and the oscillation has moved to center position. Loosen the oscillation plate bolts on top of the tractor with a 3/16" hex key and slide the

entire torch assembly to align the torch with the seam (see Figure - 15 Torch Stick Out). Leave at least two bolts overlapping the Main Body Assembly. Once in place, tighten the oscillation plate bolts starting with the bolts furthest out from the torch head and moving in. If the torch cannot reach the seam, the track may need to be repositioned. Standard oscillation plates are 6", and are included with the T55 Helix™. 12" and 24" oscillation plates are available for special applications.

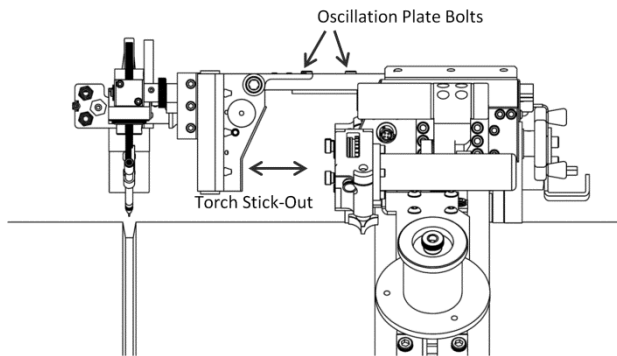

FIGURE 15 – TORCH STICK-OUT

Tungsten Stick Out

Adjust the tungsten stick-out by loosening the back cap on top of the torch (see Figure 16 – Back Cap). Move the tungsten by hand to the desired position and tighten the back cap.

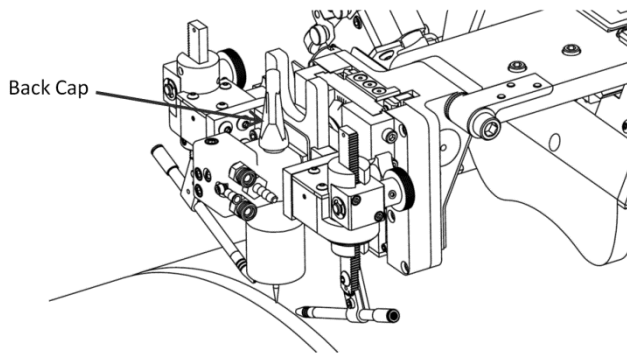

FIGURE 16 – BACK CAP

Torch Height

You can adjust the torch height by jogging the AVC. If the AVC travel range will not allow the torch to reach the desired height you will need to manually

change the torch height offset by adjusting the torch mount slide or the AVC plate mounting.

Set AVC travel range back to zero before manually adjusting.

To adjust the torch mount slide loosen the slide clamp bolts with a 5/32" hex key (see Figure 17 Side Clamp Bolts).

Slide the torch up or down as needed, then retighten the bolts.

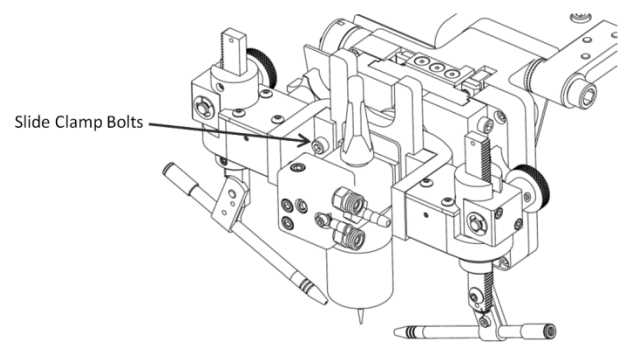

FIGURE 17 – SLIDE CLAMP BOLTS

To adjust the AVC plate mounting location, remove the torch head from the AVC assembly. Remove the barrel clamp bolts on one side of the torch with a 5/32" hex key and remove the barrel clamp (see Figure 18 – Torch Head Removal). The torch can now be removed.

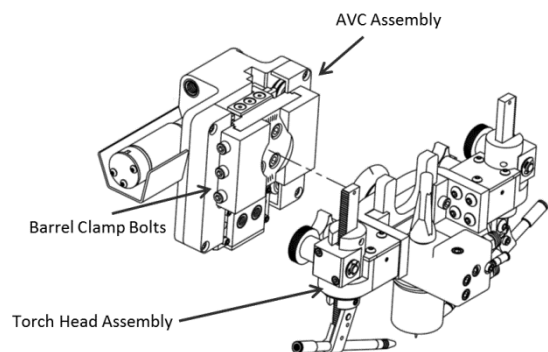

FIGURE 18 – TORCH HEAD REMOVAL

Unscrew the AVC plate bolts with a 3/16" hex key and move the AVC plate up or down (see Figure 19

– AVC Plate). The AVC plate can move to any position so long as all four bolts are re-attached.

Replace the torch and re-attach the barrel clamp. Removing the torch head may require the operator to re-adjust the lead/lag angle.

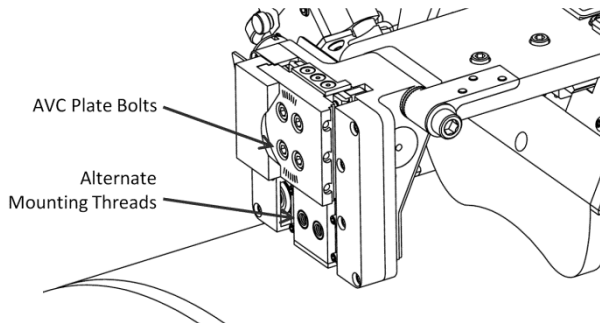

FIGURE 19 – AVC PLATE

Wire Feeder Angle

The angle of the fed wire can be adjusted for specific applications. Adjust the position of the wire guides to aim the wire.

Height adjustment is accomplished by turning the height adjustment knob on the wire manipulator unit (see Figure 20 – Wire Guide Height). The side to side angle of the wire guide can be adjusted by turning the angle adjustment knob on the wire manipulator unit.

The up-down angle of the wire guides can be changed by pressing out the wire angle pin and loosening the wire angle bolt with a 1/8" hex key (see Figure 21 – Wire Guide Adjust). Move the wire guide to the desired position and retighten the bolt.

In-out adjustment is accomplished by loosening the wire holder bolt with a 7/64" hex key. Slide the wire guide in or out and then tighten the wire holder bolt to lock it in place.

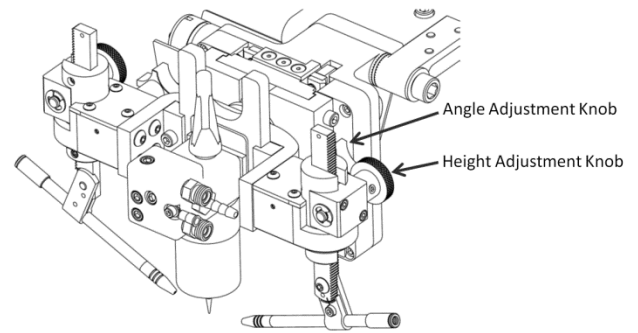

FIGURE 20 – WIRE GUIDE HEIGHT

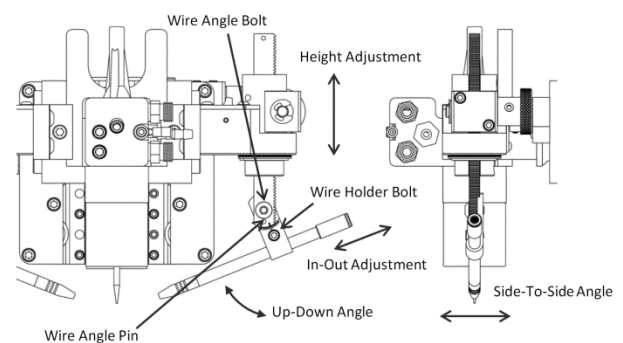

FIGURE 21 – WIRE GUIDE ADJUST

Verify Drive Rolls

Before installing wire, verify that the proper drive rolls are installed in each of the wire feed units. To check drive roller sizes, remove the cover plate from the front of the wire feed unit with a 9/64" hex key (see Figure 20 – Roller Setup). The wire diameter is stamped on the side of the lower drive roll. The standard drive roll, KP52079-35 is for 0.035" wire. Visually verify that the groove size is the same for the upper and lower drive rolls. There are 2 drive rolls per wire arm assembly.

NOTE



There are larger diameter drive rolls available: KP52079-45 for 0.045" wire, and KP52079-52 for 0.052 wire.

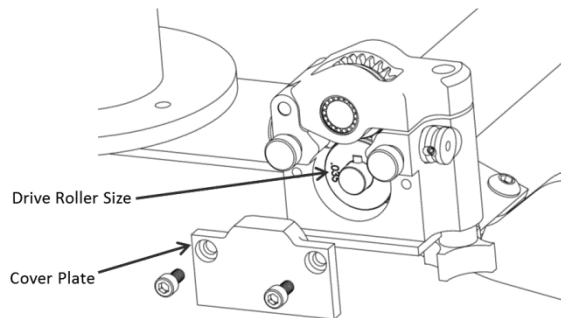

FIGURE 22 – LOWER DRIVE ROLL

Change Upper Drive Roll

If the sizes are not the same, or to change the drive rolls, start by loosening the tension knob (see Figure – 21 Tension Knob) until the upper roll can pivot away.

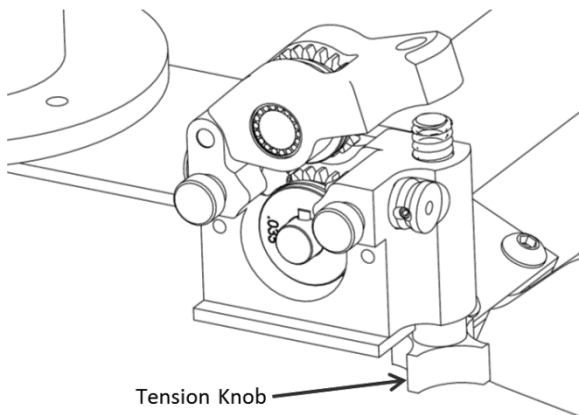

FIGURE 23 – TENSION KNOB

With the tension knob loose the upper drive roll can rotate freely. Rotate the drive roll until the set screw (see Figure 22 – Set Screw) is exposed and loosen with a .050" hex key.

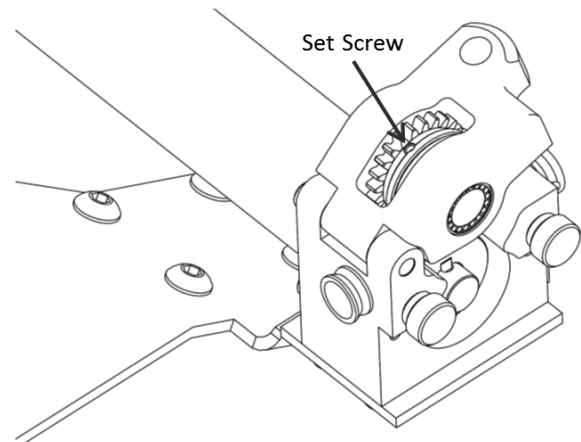

FIGURE 24 – SET SCREW

With the set screw loose slide the shaft out releasing the upper drive roll. There is an access hole on the back of the wire feed where you can insert the 7/64" hex key to push the shaft out (see Figure 23 – Drive Roll Shaft).

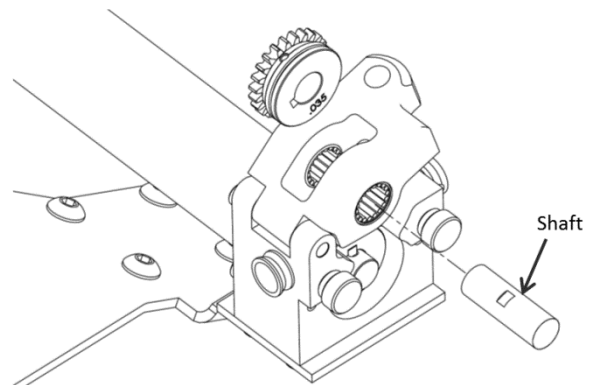

FIGURE 25 – DRIVE ROLL SHAFT

Remove the upper drive roll from the assembly.

Insert the desired drive roll back into the slot and insert the shaft through the bearings and drive roller. The shaft is notched to provide a seat for the set screw. Be sure to insert the shaft so that the notch meets up with the set screw.

Tighten set screw on upper drive roll.

Change Lower Drive Roll

With the top still pivoted away, drive the wire feed motor until the set screw for the lower drive roll is exposed. Loosen the set screw (see Figure 24 – Set Screw).

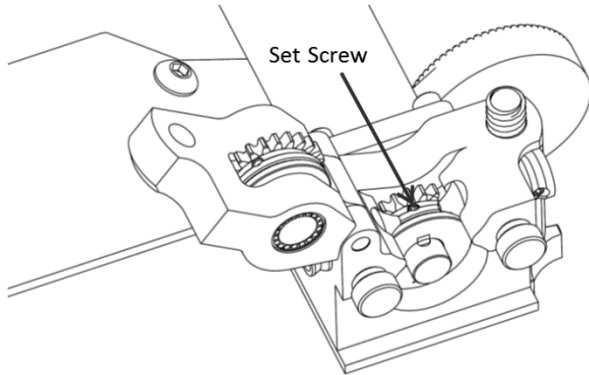

FIGURE 26 – ROLLER SET SCREW 2

Drive the wire feed motor again until the motor key is at the top of the rotation (see Figure 25 – Motor Key).

Slide the lower drive roll off the front of the motor shaft.

NOTE

Motor key is secured by lower drive roll. Take care not to lose the motor key when removing lower drive roll.

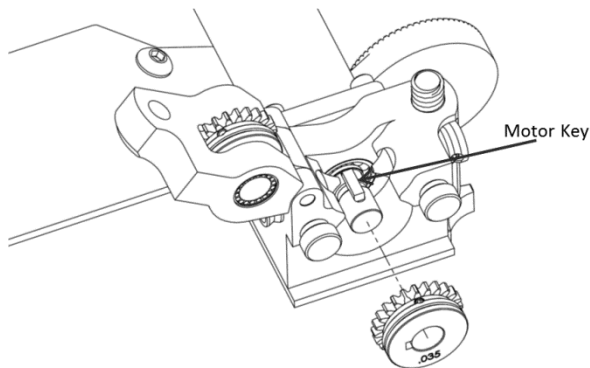

FIGURE 27 – MOTOR KEY

Ensure that the motor key is in place. Slide the correct drive roller back onto the motor shaft.

Drive the wire feed motor until the set screw is accessible. Tighten the set screw.

Attach the cover plate back to the front of the wire feed unit and adjust the tension knob back to the proper setting.

Wire Feed Setup

Once you have verified proper drive roll installation it is time to set up the wire feed. Setting up the wire feed consists of three parts:

- Installing Wire Spool
- Feeding the Wire
- Adjusting the Wire Arms

Wire Spool Installation

To install the wire spool, start by unscrewing the red hub nut from the wire hub (see Figure 26 – Hub Nut).

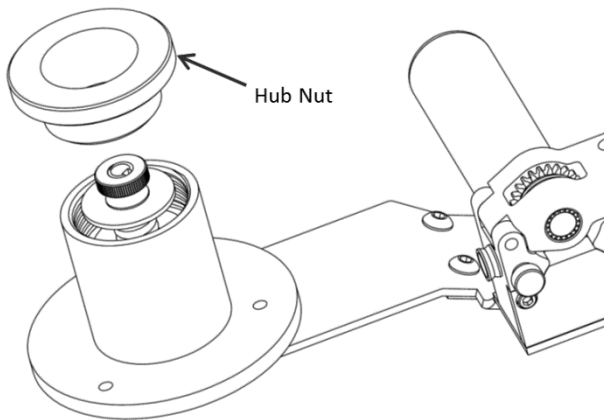

FIGURE 28 – HUB NUT

Place the wire spool over the wire hub and thread the hub nut back over the spool until it is hand tight. Turn the spool by hand to check the friction. If the spool can spin too freely then it may unwind on its own. Tighten the thumb nut on top of the wire hub to increase the rotational friction.

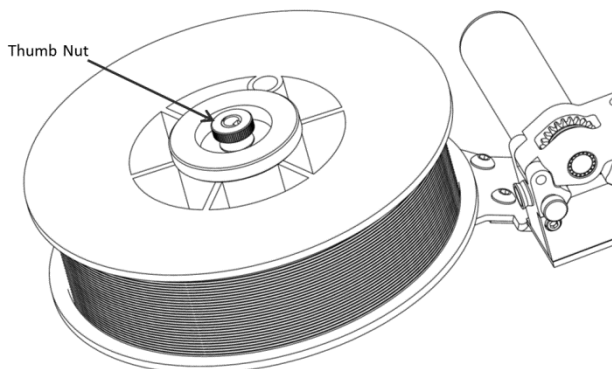

FIGURE 29 – THUMB NUT

Install the wire spools so that the wire is fed from the outside of the spool into the wire feeder (see Figure 28 – Wire 1 Installation and Figure 29 – Wire 2 Installation).

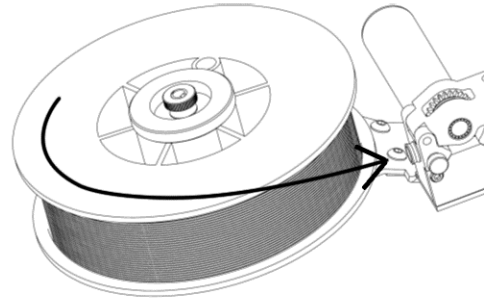

FIGURE 30 – WIRE 1 INSTALLATION

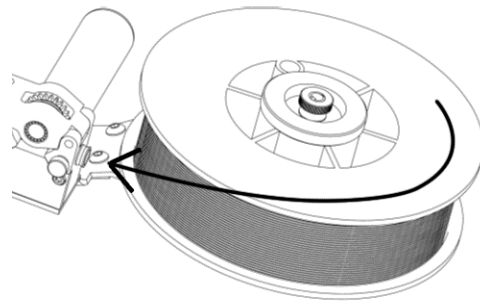

FIGURE 31 – WIRE 2 INSTALLATION

Feeding the Wire

The wire feed unit is specially designed to be self-feeding without jamming or binding.

1. Cut wire cleanly.
2. Turn on the wire feed motor in the forward direction.
3. Take the end of the wire from the spool and feed it through the inlet guide on the wire feed unit until the rollers catch and pull (see Figure 30 – Inlet Guide).
4. The wire should be fed all the way through the wire liner and come out the wire guide tip at the torch.
5. While the wire is feeding watch the wire to make sure it is not slipping. If it is slipping tight-

en the tension knob slightly to give the rollers a better grip.

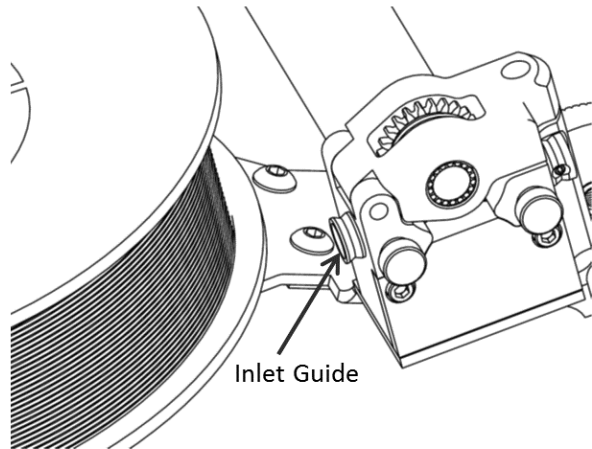

FIGURE 32 – INLET GUIDE

6. Once the wire comes out the wire guide tip stop feeding and snip the end to the appropriate starting length.

Adjustments for Radial Clearance

To achieve minimal radial profile you should adjust the wire arms to ride as close to the track as possible. To adjust the wire arms loosen the wire arm thumb screw enough so that the serrated teeth can slide past each other (see Figure 31 – Thumb Screw).

Put the wire arm to the desired position and tighten the thumb screw (see Figure 34 – Wire Arms Adjusted). The serrated teeth ensure that the wire arm will not slip out of position.

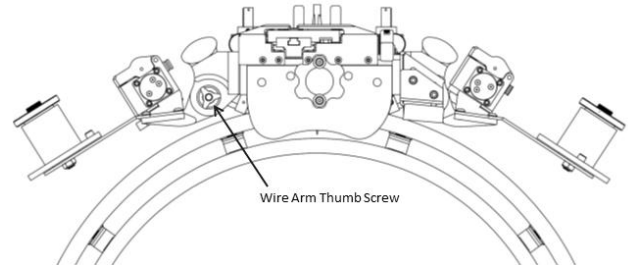

FIGURE 33 – THUMB SCREW

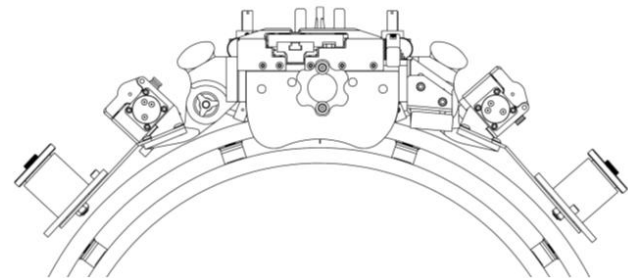

FIGURE 34 – WIRE ARMS ADJUSTED

OPERATION

For operation instructions for the T55 Helix™ refer to orbital control system manual.

MAINTENANCE

The T55 Helix™ Weld Head and Track Ring are designed for trouble free operation and normally requires minimal preventive care and cleaning. This section provides instruction for maintaining user serviceable items. The suggest repair procedure for all user serviceable items is to remove and replace defective assemblies or parts. If users and service personnel are not familiar with electrical and electronic equipment, the products should be returned to the factory or serviced by factor authorized representatives for service and/ or repair.

Preventative Maintenance Schedule

The preventative maintenance schedule is suggested as a guideline for proper system maintenance. More stringent maintenance requirements may be required depending on the work being performed and the requirements of the customer for whom the work is performed.

Track Ring

The Track Ring, shoes and extensions require little to no maintenance. When not in use it is recommended that the track ring and all components be stored out of the elements. Maintenance and cleaning should be completed as suggested or as needed.

Monthly Maintenance

Clean all dirt and debris from ring and geared track. Use a brush with plastic bristles and rubbing alcohol as required.

Quarterly Maintenance

Clean all dirt and debris from ring and geared track.

Using compressed air, blow out all dust from small hard to reach areas on the track. Verify all dust and debris is gone from track shoe bolts and threads.

Annual Maintenance

Remove track shoes and separate track sections. Using compressed air, blow out debris from threads and bolt holes.

T55 Weld Head

The T55 Weld Head requires only little to moderate cleaning and maintenance. Use rubbing alcohol and a brush with plastic bristles or a cotton swab to clean or remove excess dirt, oil and grease. When not in use it is recommended that the track ring and all components be stored inside the protective case provided with purchase. Maintenance and cleaning should be completed as suggested or as needed.

Daily Maintenance

Check tungsten for cracks, distortion or other defects. Check the Pyrex cup for cracks, discoloration or other defects. Check the diffuser (collet body) screen for blockage.

Weekly Maintenance

Check the water level of the water cooler to verify optimal water flow to the weld head.

Monthly Maintenance

Check the Weld Hoses, both gas and water for leaks.

Quarterly Maintenance

Inspect drive rolls and wire feeder rolls for dirt or debris. Clean using brush or cotton swab. Visually inspect entire unit for dirt or wear and tear. Place machine in test mode. Visually observe, and listen to AVC motion, OSC motion and Travel motion. Verify motion is smooth and uninterrupted; listen for grinding or motor stress.

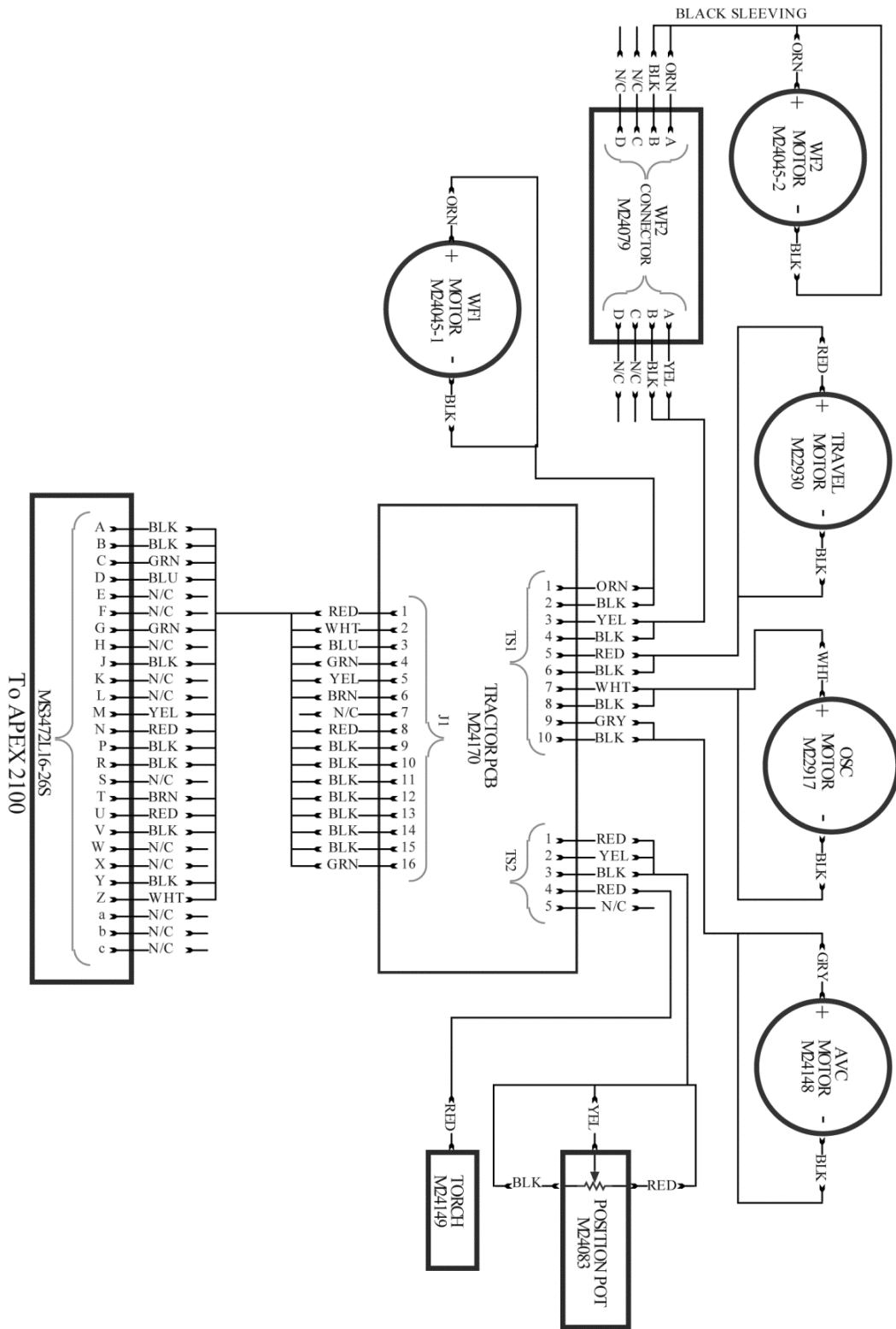

FIGURE 35 – WIRING DIAGRAM

NOTES

HELIX™ T55 WELD HEAD



PARTS LIST FOR

Helix™ T55 Weld Head

This parts list is provided as an informative guide only.

It was accurate at the time of printing. These pages are only updated on the Service Navigator DVD and in Lincoln Electric's official Parts Book (BK-34).

When ordering parts, always refer to Lincoln Electric's official Parts Book (BK-34) for the latest pages.

HELIX™ T55 WELD HEAD



ILLUSTRATION OF PARTS

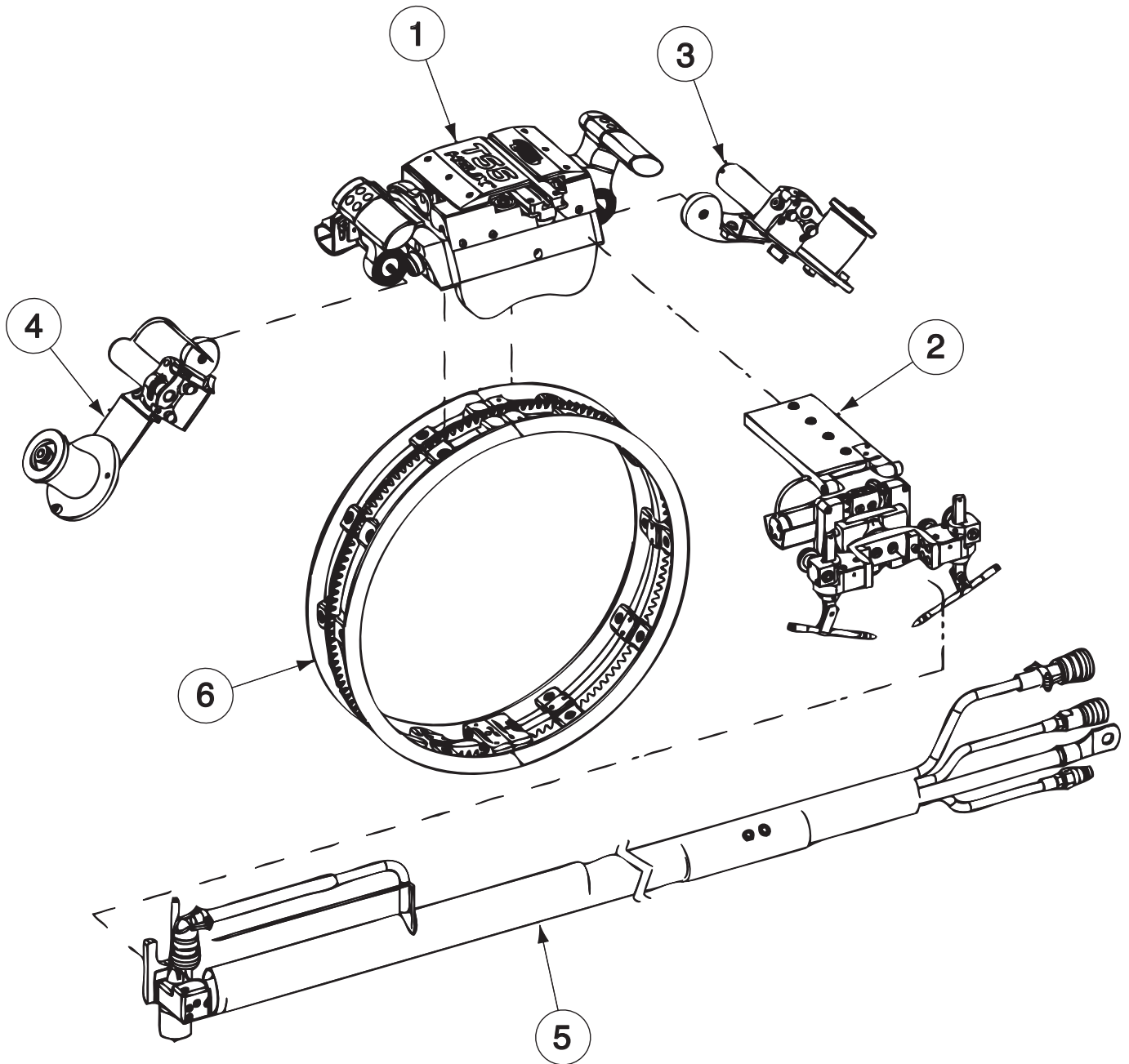

Helix™ T55 Weld Head

Do Not use this Parts List for a machine if its code number is not listed. Contact the Service Department for any code numbers not listed.

Use the Illustration of Sub-Assemblies page and the table below to determine which sub assembly page and column the desired part is located on for your particular code machine.

Sub Assembly Item No. ↔	1	1	2	3	4	5	6		
SUB ASSEMBLY PAGE NAME ↔	Main Body Assembly	Main Body Assembly (Lower)	Torch Arm Assembly	Wheel Hub (Rear)	Wheel Hub (Front)	Weld Cables	Track Ring		
PAGE NO. →	P-722-C	P-722-D	P-722-E	P-722-F	P-722-G	P-722-H	P-722-J		
CODE NO. ↓									
70301	1	1	1	1	1	1			
70300							1		



Main Body Assembly

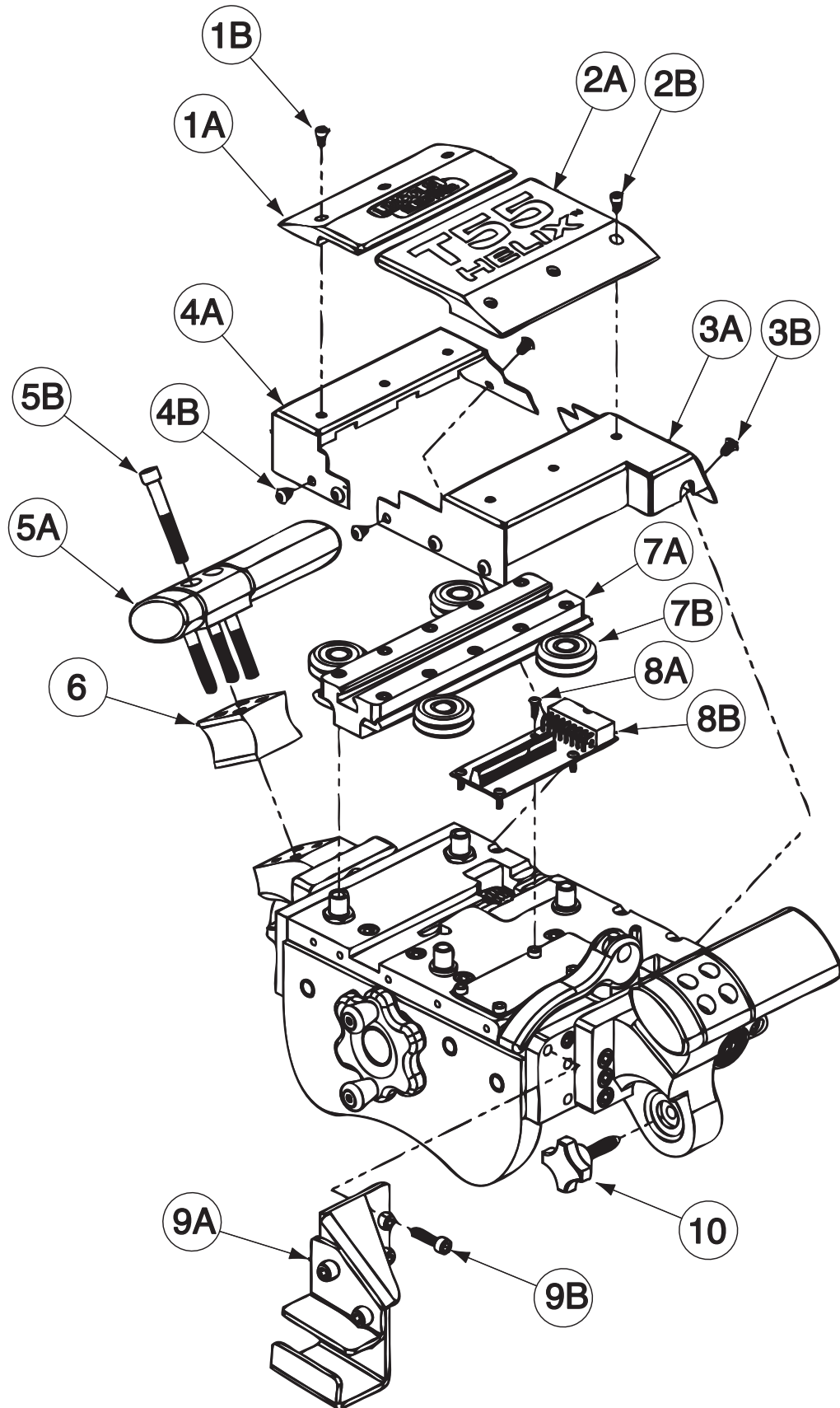

HELIX™ T55 WELD HEAD

10-15-2012



Indicates a change this printing.

Use only the parts marked "x" in the column under the heading number called for in the model index page.

ITEM	DESCRIPTION	PART NO.	QTY.	1	2	3	4	5	6	7	8	9
1	Main Body Assembly (M22911), Includes: Top Plate Kit	S29561-1	1	X								
1A	Top Plate Front		1	X								
1B	Bolt 6-32 Steel		3	X								
2	Top Plate Rear Kit	S29561-2	1	X								
2A	Top Plate Rear		1	X								
2B	Screw 6-32		3	X								
3	Top Cover Rear Kit	S29561-3	1	X								
3A	Top Cover Rear		1	X								
3B	Screw 8-32 Steel		3	X								
4	Top Plate Rear Kit	S29561-4	1	X								
4A	Top Plate Rear		1	X								
4B	Screw 8-32		3	X								
5	Handle Kit	S29561-5	1	X								
5A	Handle		1	X								
5B	Screw 1/4-20		4	X								
6	Handle Extension	M24077	1	X								
7	OSC Slide Kit	S29561-6	1	X								
7A	OSC Slide Assembly		1	X								
7B	Dual V Guide		4	X								
8	Tractor PCB Kit	S29561-7	1	X								
8A	Tractor PCB		1	X								
8B	Screw 4-40		4	X								
9	Cable Support Kit	S29561-8	1	X								
9A	Cable Support Assembly		1	X								
9B	Screw 10-24		5	X								
10	Thumb Screw	S29143	2	X								



Main Body Assembly (Lower)

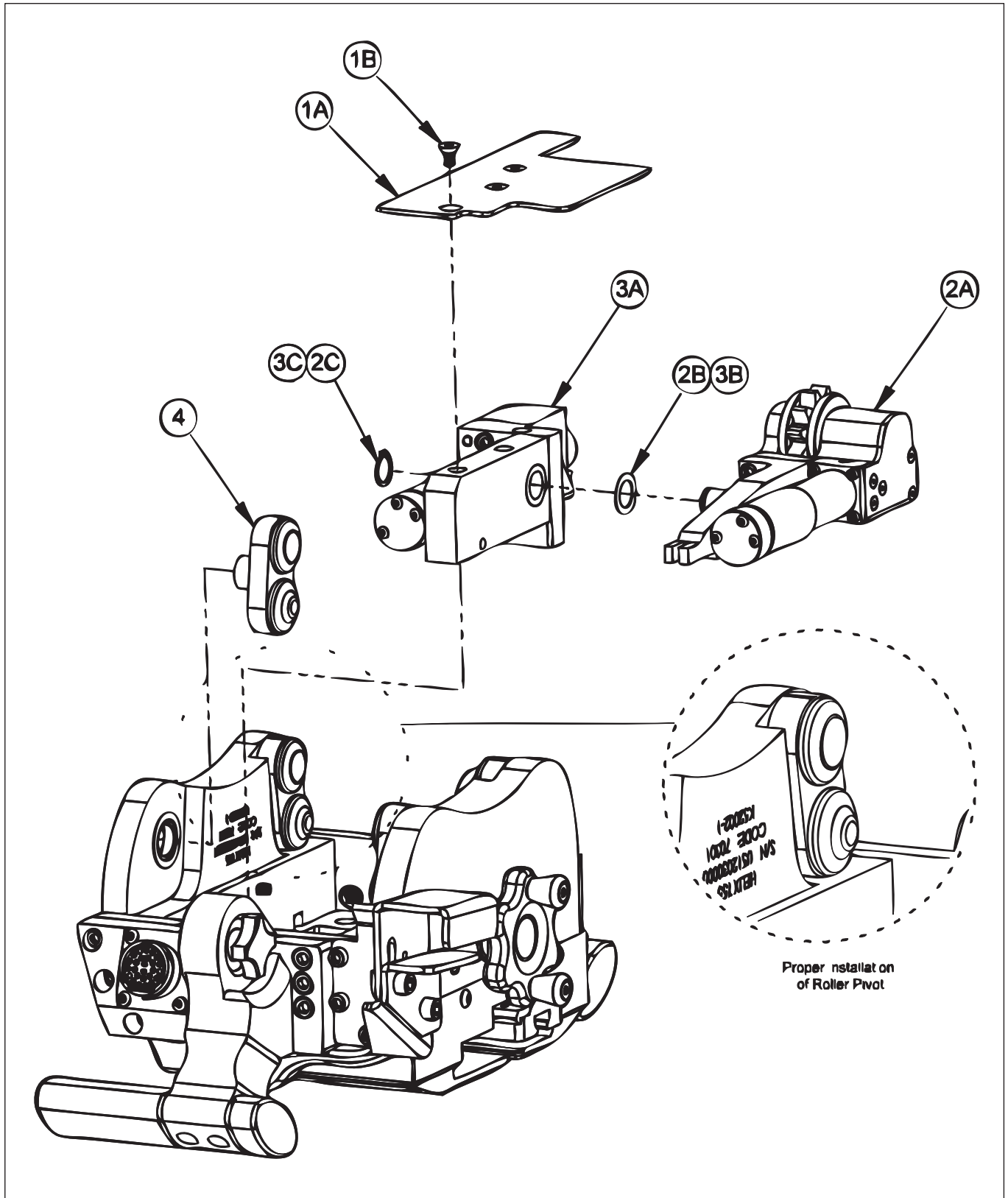

Indicates a change this printing.

Use only the parts marked "x" in the column under the heading number called for in the model index page.

ITEM	DESCRIPTION	PART NO.	QTY.	1	2	3	4	5	6	7	8	9
1	Main Body Assembly (M22911), Includes											
	Bottom Cover Plate Kit	S29561-9	1	X								
1A	Bottom Cover Plate		1	X								
1B	Screw 10-24		3	X								
2	Travel Drive Kit	S29561-10	1	X								
2A	Travel Drive		1	X								
2B	Brass Shim		1	X								
2C	External Retaining Ring		1	X								
3	Oscillation Drive Kit	S29561-11	1	X								
3A	Oscillation Drive		1	X								
3B	Brass Shim		1	X								
3C	External Retaining Ring		1	X								
4	Roller Pivot	M22949	1	X								



Torch Arm Assembly

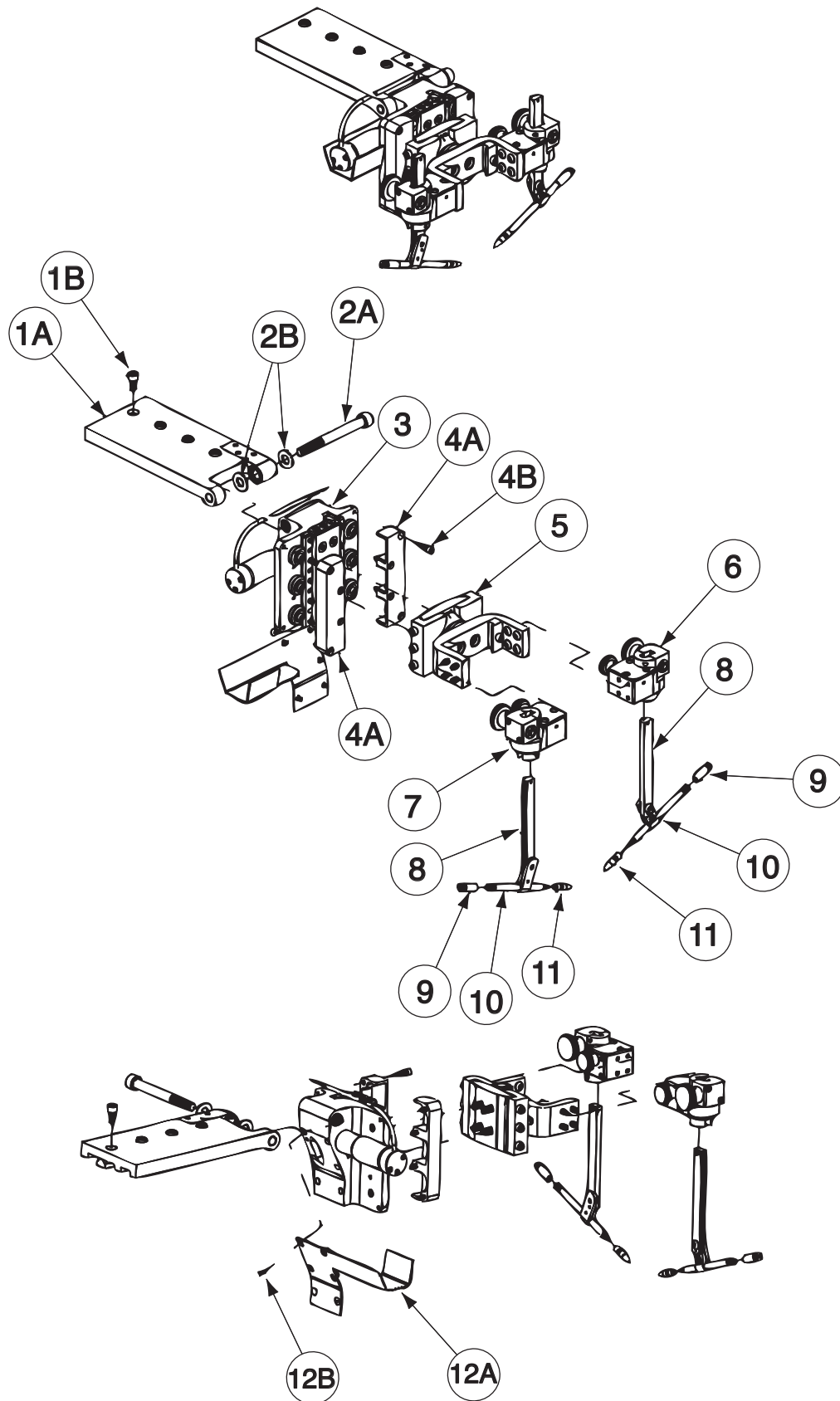

HELIX™ T55 WELD HEAD

10-15-2012



Indicates a change this printing.

Use only the parts marked "x" in the column under the heading number called for in the model index page.

ITEM	DESCRIPTION	PART NO.	QTY.	1	2	3	4	5	6	7	8	9
1	Torch Arm Assembly (M22989-X), Includes: OSC Plate Kit 6' Standard	KP52084-6	1	X								
1A	OSC Plate Assembly		1	X								
1B	Screw 1/4-20		4	X								
2	AVC Pivot Kit	S29561-13	1	X								
2A	AVC Pivot Bolt		1	X								
2B	Thrust Bearing		2	X								
3	AVC Assembly	M22997	1	X								
4	AVC Wheel Cover Kit	S29561-14	1	X								
4A	AVC Wheel Cover		1	X								
4B	Screw 8-32		4	X								
5	Torch Mount Bracket Assembly	M24038	1	X								
6	Wire Manipulator Front	M24013	1	X								
7	Wire Manipulator Rear	M24029	1	X								
8	Gear Rack	M24020	1	X								
9	Wire Guide Coupler	KP52086-035	2	X								
10	Wire Guide Tube	KP52087	2	X								
11	Wire Guide Tip	KP52088-035	2	X								
12	AVC Cover Plate Kit	S29561-15	1	X								
12A	AVC Cover Plate		1	X								
12B	Screw 6-32		6	X								



Wire Hub (Rear)

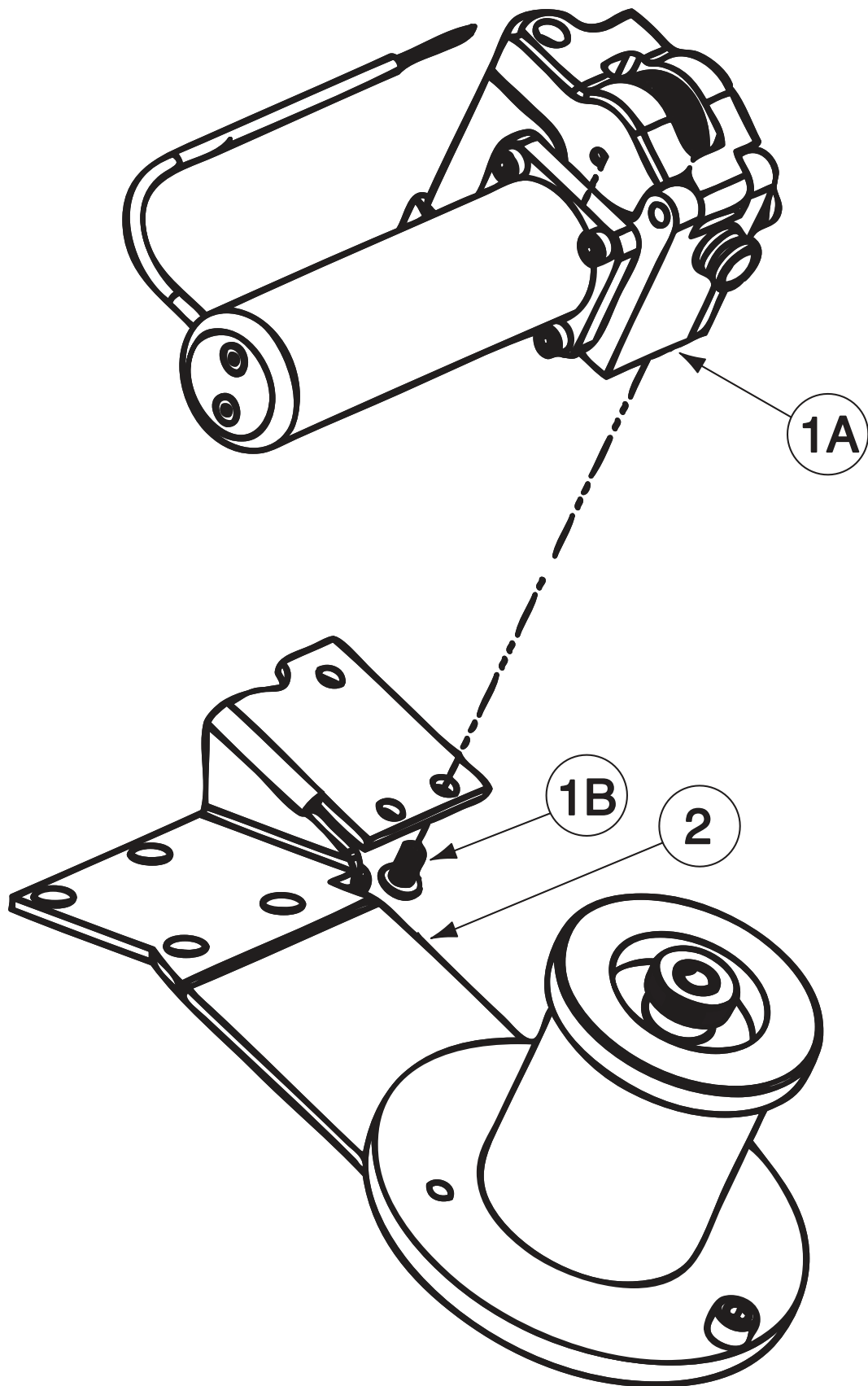

Indicates a change this printing.

Use only the parts marked "x" in the column under the heading number called for in the model index page.

ITEM	DESCRIPTION	PART NO.	QTY.	1	2	3	4	5	6	7	8	9
1	Wire Hub Rear (M24029), Includes	S29561-16	1	X								
1A	Wire Feed Kit Rear		1	X								
1B	Wire Feed		3	X								
2	BHCS 10-24, Steel, Black Oxide	M24060-1	1	X								
	Wire Hub Rear											



Wire Hub (Front)

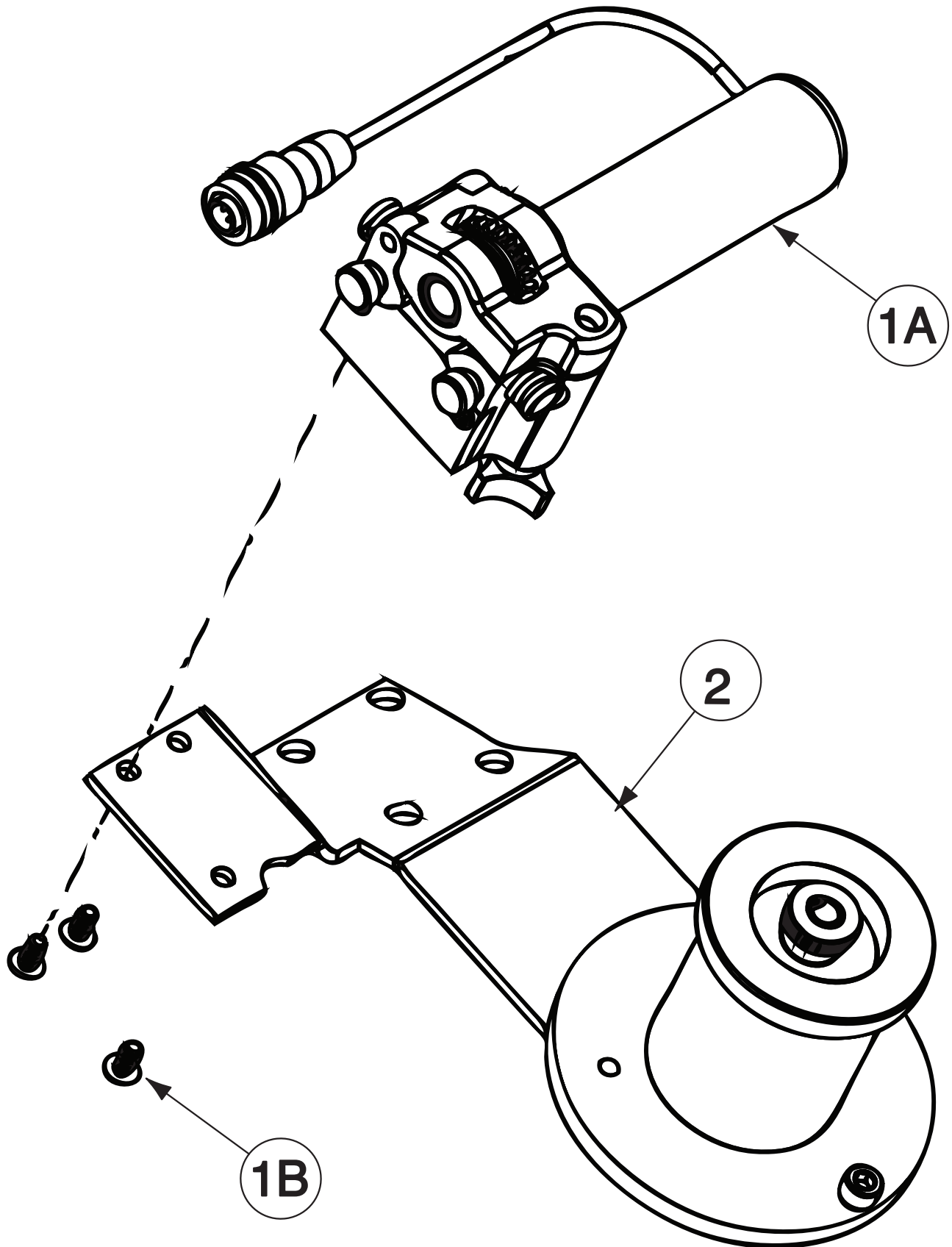

Indicates a change this printing.

Use only the parts marked "x" in the column under the heading number called for in the model index page.

ITEM	DESCRIPTION	PART NO.	QTY.	1	2	3	4	5	6	7	8	9
1	Wire Hub Front (M24029), Includes	S29561-19	1	X								
1A	Wire Feed Kit Front		1	X								
1B	Wire Feed		3	X								
2	BHCS 10-24, Steel, Black Oxide	M24060-2	1	X								
	Wire Hub Front											



Weld Cables

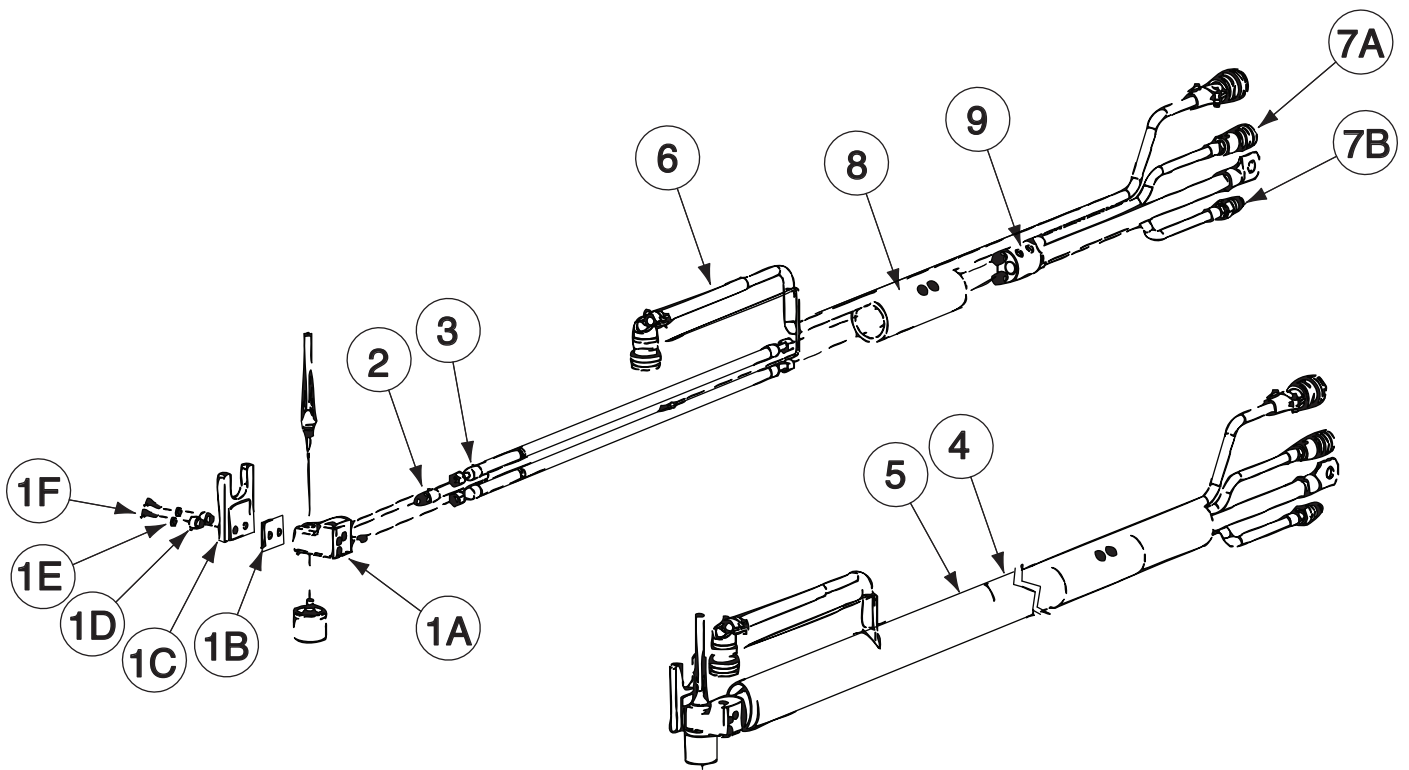

Indicates a change this printing.

Use only the parts marked "x" in the column under the heading number called for in the model index page.

ITEM	DESCRIPTION	PART NO.	QTY.	1	2	3	4	5	6	7	8	9
1	Torch Arm Assembly (M22989-X), Includes:	S29561-17	1	X								
1A	Torch Head Kit		1	X								
1B	Torch Head		1	X								
1C	Torch Insulator		1	X								
1D	Torch Mount Slide		1	X								
1E	Bolt Insulator		2	X								
1F	Washer, Narrow		2	X								
1F	Screw 8-32	2	X									
2	T55 Gas Hose Assembly	M24162	1	X								
3	Cable Hose Assembly	S29089	1	X								
4	Canvas Cover	S29090-23	1	X								
5	High Temp Sleeve	S29327	1	X								
6	Control Cable Assembly	M24161	1	X								
7	Tractor Hose Kit	S29561-20	1	X								
7A	Water Hose Female		1	X								
7B	Water Hose Male		1	X								
8	Squid Cover Kit	S29561-21	1	X								
8A	Plastic Squid Cover		1	X								
8B	Nylon Set Screw Modifier (Not Shown)		1	X								
9	Squid Kit	S29561-22	1	X								
9A	Squid Power/Water Block		1	X								
9B	Set Screw Cup Point 1/2-20		1	X								



Track Ring

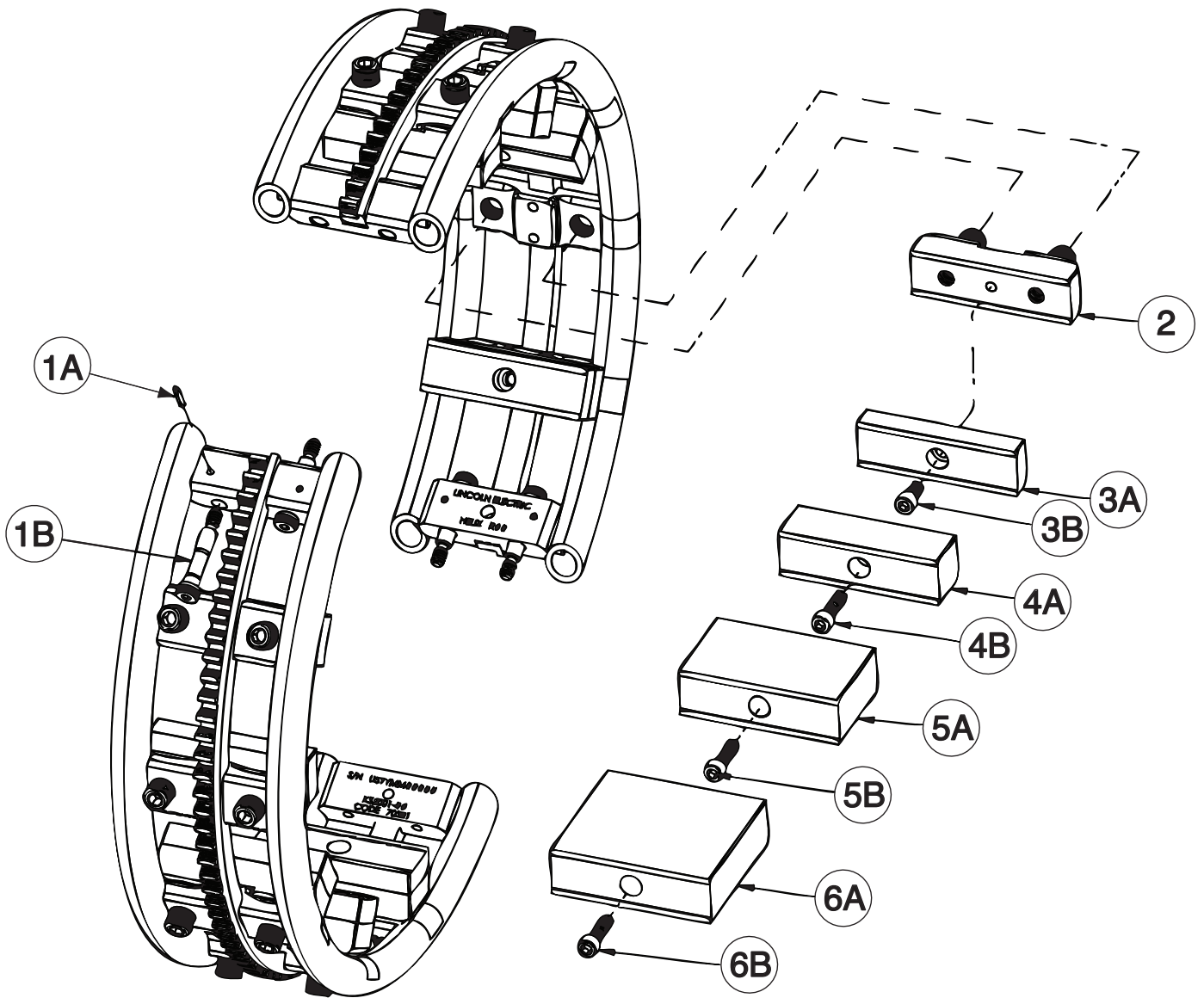

Indicates a change this printing.

Use only the parts marked "x" in the column under the heading number called for in the model index page.

ITEM	DESCRIPTION	PART NO.	QTY.	1	2	3	4	5	6	7	8	9
1	Helix™ Track Ring (K52000-XX), Includes:											
	Shoulder Bolt Kit	S29561-18	1	X								
1A	Shoulder Bolt		2	X								
1B	Retaining Ring		2	X								
2	Track Shoe	KP50281-1	1	X								
3	1/2' Extension Kit	K52060-05	1	X								
3A	1/2' Shoe Extension		1	X								
3B	Screw 1/4-20		1	X								
4	1' Extension Kit	K52060-10	1	X								
4A	1' Shoe Extension		1	X								
4B	Screw 1/4-20		1	X								
5	2' Extension Kit	K52060-20	1	X								
5A	2' Shoe Extension		1	X								
5B	Screw 1/4-20		1	X								
6	3' Extension Kit	K52060-30	1	X								
6A	3' Shoe Extension		1	X								
6B	Screw 1/4-20		1	X								



NOTES

HELIX™ T55 WELD HEAD



NOTES

Index

A

Angle Adjustment Knob	19
AVC	ii, 1, 2, 9, 19
AVC Assembly	19
AVC Motor.....	19
AVC Plate.....	19
AVC Plate Bolts.....	19
AVC Rollers.....	19

B

Barrel Clamp.....	19
Barrel Clamp Bolts.....	19

C

Cable Support.....	17
Carrying Handles	17
chromoly	1
clamping knob.....	7
Clamping Knob	17
clamping screws	5
clutch	1, 7
Clutch Latch.....	17
Control Cable Connector	17
Cover Plate.....	21
cross brace.....	4

D

drive roll	1, 11
Drive Roller.....	21

E

End Cap.....	1
Extension	3

F

Fillet Adjustment Bolt	19
Fillet Weld Angle.....	8
four segment tracks.....	3
front wire arm	1
Front Wire Arm	16

G

GTAW	1
Guide Thumb Screws	21

H

Handle Extensions	17
Height Adjustment Knob	19
Helix™	i, 1
Hub Nut	21

I

Inlet Guide.....	21
------------------	----

L

Lead/Lag Angle.....	1, 8
---------------------	------

M

main body	1
Main Body	8, 16, 17

O

Orbital.....	1, 7
Oscillation Plate.....	19
oscillation plate bolts	8
Oscillation Rollers.....	17
Outlet Guide.....	21

P

pipe expansion.....	6
---------------------	---

R

rear wire arm	1
Rear Wire Arm (optional)	16

S

skid plate.....	7
Skid Plate.....	17

T

T55 Helix™	1
Tension Knob.....	21
Thumb Nut	21
Top Covers.....	17
Torch	i, 1, 8, 16, 19
torch arm assembly	1
Torch Arm Assembly	16, 19
Torch Head Assembly	19
Torch Mount Slide.....	19

torch stick-out.....	8
track.....	1, 3, 4, 5, 6, 7, 8, 13
Track Rail	1
track ring	3, 5
Track Rollers.....	17
track shoes	4
Tractor PCB	17
Travel Drive Gear	17
Tungsten Stick Out.....	8
Two segment tracks	3

W

Weld Head.....	i, 1, 7
Wire Angle Bolt	19
Wire Feed	i, 11, 17, 21
Wire Feed 2 Connector	17
Wire Feed Motor.....	21
wire feed motors	7
Wire Guide	19
Wire Guides.....	8
Wire Holder Bolt.....	19
Wire Hub	21
Wire Manipulator.....	19

WARNING	<ul style="list-style-type: none"> ● Do not touch electrically live parts or electrode with skin or wet clothing. ● Insulate yourself from work and ground. 	<ul style="list-style-type: none"> ● Keep flammable materials away. 	<ul style="list-style-type: none"> ● Wear eye, ear and body protection.
Spanish AVISO DE PRECAUCION	<ul style="list-style-type: none"> ● No toque las partes o los electrodos bajo carga con la piel o ropa mojada. ● Aíslese del trabajo y de la tierra. 	<ul style="list-style-type: none"> ● Mantenga el material combustible fuera del área de trabajo. 	<ul style="list-style-type: none"> ● Protéjase los ojos, los oídos y el cuerpo.
French ATTENTION	<ul style="list-style-type: none"> ● Ne laissez ni la peau ni des vêtements mouillés entrer en contact avec des pièces sous tension. ● Isolez-vous du travail et de la terre. 	<ul style="list-style-type: none"> ● Gardez à l'écart de tout matériel inflammable. 	<ul style="list-style-type: none"> ● Protégez vos yeux, vos oreilles et votre corps.
German WARNUNG	<ul style="list-style-type: none"> ● Berühren Sie keine stromführenden Teile oder Elektroden mit Ihrem Körper oder feuchter Kleidung! ● Isolieren Sie sich von den Elektroden und dem Erdboden! 	<ul style="list-style-type: none"> ● Entfernen Sie brennbares Material! 	<ul style="list-style-type: none"> ● Tragen Sie Augen-, Ohren- und Körperschutz!
Portuguese ATENÇÃO	<ul style="list-style-type: none"> ● Não toque partes elétricas e electrodos com a pele ou roupa molhada. ● Isole-se da peça e terra. 	<ul style="list-style-type: none"> ● Mantenha inflamáveis bem guardados. 	<ul style="list-style-type: none"> ● Use proteção para a vista, ouvido e corpo.
Japanese 注意事項	<ul style="list-style-type: none"> ● 通電中の電気部品、又は溶材にヒフやぬれた布で触れないこと。 ● 施工物やアースから身体が絶縁されている様にして下さい。 	<ul style="list-style-type: none"> ● 燃えやすいものの側での溶接作業は絶対にはなりません。 	<ul style="list-style-type: none"> ● 目、耳及び身体に保護具をして下さい。
Chinese 警告	<ul style="list-style-type: none"> ● 皮肤或湿衣物切勿接觸帶電部件及綽條。 ● 使你自已與地面和工件絕緣。 	<ul style="list-style-type: none"> ● 把一切易燃物品移離工作場所。 	<ul style="list-style-type: none"> ● 佩戴眼、耳及身體勞動保護用具。
Korean 위험	<ul style="list-style-type: none"> ● 전도체나 웅접봉을 젖은 형깁 또는 피부로 절대 접촉치 마십시오. ● 모재와 접지를 접촉치 마십시오. 	<ul style="list-style-type: none"> ● 인화성 물질을 접근 시키지 마십시오. 	<ul style="list-style-type: none"> ● 눈, 귀와 몸에 보호장구를 착용하십시오.
Arabic تحذير	<ul style="list-style-type: none"> ● لا تلمس الاجزاء التي يسري فيها التيار الكهربائي أو الألكترود بجلد الجسم أو بالملابس المبللة بالماء. ● ضع عازلا على جسمك خلال العمل. 	<ul style="list-style-type: none"> ● ضع المواد القابلة للاشتعال في مكان بعيد. 	<ul style="list-style-type: none"> ● ضع أدوات وملابس واقية على عينيك وأذنيك وجسمك.

READ AND UNDERSTAND THE MANUFACTURER'S INSTRUCTION FOR THIS EQUIPMENT AND THE CONSUMABLES TO BE USED AND FOLLOW YOUR EMPLOYER'S SAFETY PRACTICES.

SE RECOMIENDA LEER Y ENTENDER LAS INSTRUCCIONES DEL FABRICANTE PARA EL USO DE ESTE EQUIPO Y LOS CONSUMIBLES QUE VA A UTILIZAR, SIGA LAS MEDIDAS DE SEGURIDAD DE SU SUPERVISOR.

LISEZ ET COMPRENEZ LES INSTRUCTIONS DU FABRICANT EN CE QUI REGARDE CET EQUIPMENT ET LES PRODUITS A ETRE EMPLOYES ET SUIVEZ LES PROCEDURES DE SECURITE DE VOTRE EMPLOYEUR.

LESEN SIE UND BEFOLGEN SIE DIE BETRIEBSANLEITUNG DER ANLAGE UND DEN ELEKTRODENEINSATZ DES HERSTELLERS. DIE UNFALLVERHÜTUNGSVORSCHRIFTEN DES ARBEITGEBERS SIND EBENFALLS ZU BEACHTEN.

			
<ul style="list-style-type: none"> ● Keep your head out of fumes. ● Use ventilation or exhaust to remove fumes from breathing zone. 	<ul style="list-style-type: none"> ● Turn power off before servicing. 	<ul style="list-style-type: none"> ● Do not operate with panel open or guards off. 	WARNING
<ul style="list-style-type: none"> ● Los humos fuera de la zona de respiración. ● Mantenga la cabeza fuera de los humos. Utilice ventilación o aspiración para gases. 	<ul style="list-style-type: none"> ● Desconectar el cable de alimentación de poder de la máquina antes de iniciar cualquier servicio. 	<ul style="list-style-type: none"> ● No operar con panel abierto o guardas quitadas. 	Spanish AVISO DE PRECAUCION
<ul style="list-style-type: none"> ● Gardez la tête à l'écart des fumées. ● Utilisez un ventilateur ou un aspirateur pour ôter les fumées des zones de travail. 	<ul style="list-style-type: none"> ● Débranchez le courant avant l'entretien. 	<ul style="list-style-type: none"> ● N'opérez pas avec les panneaux ouverts ou avec les dispositifs de protection enlevés. 	French ATTENTION
<ul style="list-style-type: none"> ● Vermeiden Sie das Einatmen von Schweißrauch! ● Sorgen Sie für gute Be- und Entlüftung des Arbeitsplatzes! 	<ul style="list-style-type: none"> ● Strom vor Wartungsarbeiten abschalten! (Netzstrom völlig öffnen; Maschine anhalten!) 	<ul style="list-style-type: none"> ● Anlage nie ohne Schutzgehäuse oder Innenschutzverkleidung in Betrieb setzen! 	German WARNUNG
<ul style="list-style-type: none"> ● Mantenha seu rosto da fumaça. ● Use ventilação e exaustão para remover fumo da zona respiratória. 	<ul style="list-style-type: none"> ● Não opere com as tampas removidas. ● Desligue a corrente antes de fazer serviço. ● Não toque as partes elétricas nuas. 	<ul style="list-style-type: none"> ● Mantenha-se afastado das partes moventes. ● Não opere com os painéis abertos ou guardas removidas. 	Portuguese ATENÇÃO
<ul style="list-style-type: none"> ● ヒュームから頭を離すようにして下さい。 ● 換気や排煙に十分留意して下さい。 	<ul style="list-style-type: none"> ● メンテナンス・サービスに取りかかる際には、まず電源スイッチを必ず切って下さい。 	<ul style="list-style-type: none"> ● パネルやカバーを取り外したままで機械操作をしないで下さい。 	Japanese 注意事項
<ul style="list-style-type: none"> ● 頭部遠離煙霧。 ● 在呼吸區使用通風或排風器除煙。 	<ul style="list-style-type: none"> ● 維修前切斷電源。 	<ul style="list-style-type: none"> ● 儀表板打開或沒有安全罩時不準作業。 	Chinese 警告
<ul style="list-style-type: none"> ● 얼굴로부터 용접가스를 멀리하십시오. ● 호흡지역으로부터 용접가스를 제거하기 위해 가스제거기나 통풍기를 사용하십시오. 	<ul style="list-style-type: none"> ● 보수전에 전원을 차단하십시오. 	<ul style="list-style-type: none"> ● 판넬이 열린 상태로 작동치 마십시오. 	Korean 위험
<ul style="list-style-type: none"> ● ابعء رأسك بعيداً عن الدخان. ● استعمل التهوية أو جهاز ضغط الدخان للخارج لكي تبعد الدخان عن المنطقة التي تتنفس فيها. 	<ul style="list-style-type: none"> ● اقطع التيار الكهربائي قبل القيام بأية صيانة. 	<ul style="list-style-type: none"> ● لا تشغيل هذا الجهاز اذا كانت الاغطية الحديدية الواقية ليست عليه. 	Arabic تحذير

LEIA E COMPREENDA AS INSTRUÇÕES DO FABRICANTE PARA ESTE EQUIPAMENTO E AS PARTES DE USO, E SIGA AS PRÁTICAS DE SEGURANÇA DO EMPREGADOR.

使う機械や溶材のメーカーの指示書をよく読み、まず理解して下さい。そして貴社の安全規定に従って下さい。

請詳細閱讀並理解製造廠提供的說明以及應該使用的銀焊材料，並請遵守貴方的有關勞動保護規定。

이 제품에 동봉된 작업지침서를 숙지하시고 귀사의 작업자 안전수칙을 준수하시기 바랍니다.

اقرأ بتمعن وافهم تعليمات المصنع المنتج لهذه المعدات والمواد قبل استعمالها واتبع تعليمات الوقاية لصاحب العمل.



• World's Leader in Welding and Cutting Products •

• Sales and Service through Subsidiaries and Distributors Worldwide •

Cleveland, Ohio 44117-1199 U.S.A. TEL: 216.481.8100 FAX: 216.486.1751 WEB SITE: www.lincolnelectric.com