

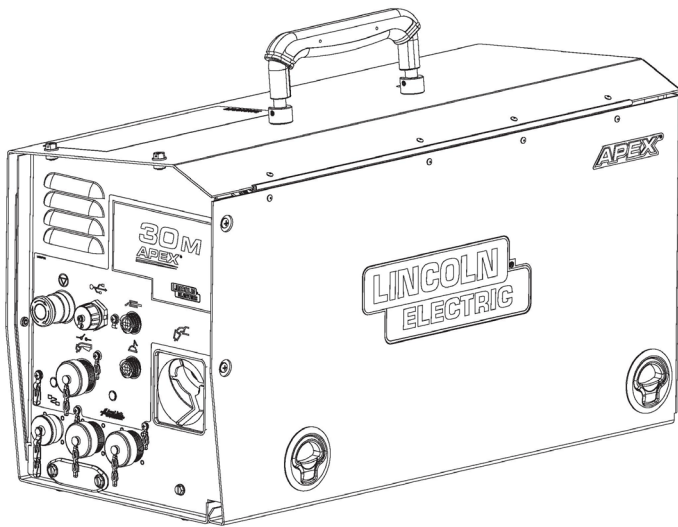

Operator's Manual

APEX® 30M CONTROL



For use with machines having Code Numbers:
12675, 12860



Register your machine:
www.lincolnelectric.com/register
Authorized Service and Distributor Locator:
www.lincolnelectric.com/locator

Save for future reference

Date Purchased

Code: (ex: 12675)

Serial: (ex: U1060512345)

Need Help? In the USA and Canada, call
1.800.770.0063 to talk to a Service Representative.

Hours of Operation:
7:00 AM to 5:00 PM (PT) Mon. thru Fri.

After hours?
Use "Ask the Experts" at lincolnelectric.com
A Lincoln Service Representative will contact you
no later than the following business day.

For Service outside the USA and Canada, please call
1.619.628.1022 or e-mail us at:
orbitalsupport@lincolnelectric.com

THE LINCOLN ELECTRIC COMPANY

22801 St. Clair Avenue • Cleveland, OH • 44117-1199 • U.S.A.
Phone: +1.216.481.8100 • www.lincolnelectric.com

LINCOLN ELECTRIC EUROPE S.L.

c/o Balmes, 89 - 8º 2ª
08008 Barcelona
SPAIN

IM6120 | Issue Date 10/18

© Lincoln Global, Inc. All Rights Reserved.

THANK YOU FOR SELECTING A QUALITY PRODUCT BY LINCOLN ELECTRIC.

PLEASE EXAMINE CARTON AND EQUIPMENT FOR DAMAGE IMMEDIATELY

When this equipment is shipped, title passes to the purchaser upon receipt by the carrier. Consequently, Claims for material damaged in shipment must be made by the purchaser against the transportation company at the time the shipment is received.

SAFETY DEPENDS ON YOU

Lincoln arc welding and cutting equipment is designed and built with safety in mind. However, your overall safety can be increased by proper installation ... and thoughtful operation on your part.

DO NOT INSTALL, OPERATE OR REPAIR THIS EQUIPMENT WITHOUT READING THIS MANUAL AND THE SAFETY PRECAUTIONS CONTAINED THROUGHOUT. Most importantly **BE CAREFUL!** Have a plan in place before you start any arc welding project.

WARNING

This statement appears where the information must be followed exactly to avoid serious personal injury or loss of life.

CAUTION

This statement appears where the information must be followed to avoid minor personal injury or damage to this equipment.



KEEP YOUR HEAD OUT OF THE FUMES.

DON'T get too close to the arc. Use corrective lenses if necessary to stay a reasonable distance away from the arc.

READ and obey the Material Safety Data Sheet (MSDS) and the warning label that appears on all containers of welding materials.

USE ENOUGH VENTILATION or exhaust at the arc, or both, to keep the fumes and gases from your breathing zone and the general area.

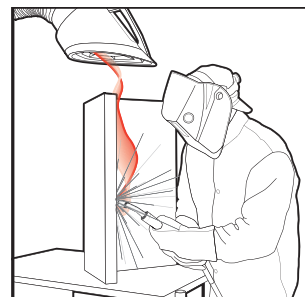

IN A LARGE ROOM OR OUTDOORS, natural ventilation may be adequate if you keep your head out of the fumes (see below).

USE NATURAL DRAFTS or fans to keep the fumes away from your face.

If you develop unusual symptoms, see your supervisor. Perhaps the welding atmosphere and ventilation system should be checked.

WEAR CORRECT EYE, EAR & BODY PROTECTION

PROTECT your eyes and face with welding helmet properly fitted and with proper grade of filter plate (See ANSI Z49.1).

PROTECT your body from welding spatter and arc flash with protective clothing including woolen clothing, flame-proof apron and gloves, leather leggings, and high boots.

PROTECT others from splatter, flash, and glare with protective screens or barriers.

IN SOME AREAS, protection from noise may be appropriate.

BE SURE protective equipment is in good condition.

Also, wear safety glasses in work area **AT ALL TIMES.**



SPECIAL SITUATIONS

DO NOT WELD OR CUT containers or materials which previously had been in contact with hazardous substances unless they are properly cleaned. This is extremely dangerous.



DO NOT WELD OR CUT painted or plated parts unless special precautions with ventilation have been taken. They can release highly toxic fumes or gases.

Additional precautionary measures

PROTECT compressed gas cylinders from excessive heat, mechanical shocks, and arcs; fasten cylinders so they cannot fall.

BE SURE cylinders are never grounded or part of an electrical circuit.

REMOVE all potential fire hazards from welding area.

ALWAYS HAVE FIRE FIGHTING EQUIPMENT READY FOR IMMEDIATE USE AND KNOW HOW TO USE IT.



SECTION A: WARNINGS



CALIFORNIA PROPOSITION 65 WARNINGS

Diesel Engines

Diesel engine exhaust and some of its constituents are known to the State of California to cause cancer, birth defects, and other reproductive harm.

Gasoline Engines

The engine exhaust from this product contains chemicals known to the State of California to cause cancer, birth defects, or other reproductive harm.



ARC WELDING CAN BE HAZARDOUS. PROTECT YOURSELF AND OTHERS FROM POSSIBLE SERIOUS INJURY OR DEATH. KEEP CHILDREN AWAY. PACEMAKER WEARERS SHOULD CONSULT WITH THEIR DOCTOR BEFORE OPERATING.

Read and understand the following safety highlights. For additional safety information, it is strongly recommended that you purchase a copy of "Safety in Welding & Cutting - ANSI Standard Z49.1" from the American Welding Society, P.O. Box 351040, Miami, Florida 33135 or CSA Standard W117.2-1974. A Free copy of "Arc Welding Safety" booklet E205 is available from the Lincoln Electric Company, 22801 St. Clair Avenue, Cleveland, Ohio 44117-1199.

BE SURE THAT ALL INSTALLATION, OPERATION, MAINTENANCE AND REPAIR PROCEDURES ARE PERFORMED ONLY BY QUALIFIED INDIVIDUALS.



FOR ENGINE-POWERED EQUIPMENT.

- 1.a. Turn the engine off before troubleshooting and maintenance work unless the maintenance work requires it to be running. 
- 1.b. Operate engines in open, well-ventilated areas or vent the engine exhaust fumes outdoors.
- 1.c. Do not add the fuel near an open flame welding arc or when the engine is running. Stop the engine and allow it to cool before refueling to prevent spilled fuel from vaporizing on contact with hot engine parts and igniting. Do not spill fuel when filling tank. If fuel is spilled, wipe it up and do not start engine until fumes have been eliminated. 

- 1.d. Keep all equipment safety guards, covers and devices in position and in good repair. Keep hands, hair, clothing and tools away from V-belts, gears, fans and all other moving parts when starting, operating or repairing equipment. 

- 1.e. In some cases it may be necessary to remove safety guards to perform required maintenance. Remove guards only when necessary and replace them when the maintenance requiring their removal is complete. Always use the greatest care when working near moving parts.
- 1.f. Do not put your hands near the engine fan. Do not attempt to override the governor or idler by pushing on the throttle control rods while the engine is running.
- 1.g. To prevent accidentally starting gasoline engines while turning the engine or welding generator during maintenance work, disconnect the spark plug wires, distributor cap or magneto wire as appropriate.

- 1.h. To avoid scalding, do not remove the radiator pressure cap when the engine is hot. 



ELECTRIC AND MAGNETIC FIELDS MAY BE DANGEROUS

- 2.a. Electric current flowing through any conductor causes localized Electric and Magnetic Fields (EMF). Welding current creates EMF fields around welding cables and welding machines. 
- 2.b. EMF fields may interfere with some pacemakers, and welders having a pacemaker should consult their physician before welding.
- 2.c. Exposure to EMF fields in welding may have other health effects which are now not known.
- 2.d. All welders should use the following procedures in order to minimize exposure to EMF fields from the welding circuit:
 - 2.d.1. Route the electrode and work cables together - Secure them with tape when possible.
 - 2.d.2. Never coil the electrode lead around your body.
 - 2.d.3. Do not place your body between the electrode and work cables. If the electrode cable is on your right side, the work cable should also be on your right side.
 - 2.d.4. Connect the work cable to the workpiece as close as possible to the area being welded.
 - 2.d.5. Do not work next to welding power source.



ELECTRIC SHOCK CAN KILL.



- 3.a. The electrode and work (or ground) circuits are electrically “hot” when the welder is on. Do not touch these “hot” parts with your bare skin or wet clothing. Wear dry, hole-free gloves to insulate hands.
- 3.b. Insulate yourself from work and ground using dry insulation. Make certain the insulation is large enough to cover your full area of physical contact with work and ground.

In addition to the normal safety precautions, if welding must be performed under electrically hazardous conditions (in damp locations or while wearing wet clothing; on metal structures such as floors, gratings or scaffolds; when in cramped positions such as sitting, kneeling or lying, if there is a high risk of unavoidable or accidental contact with the workpiece or ground) use the following equipment:

- Semiautomatic DC Constant Voltage (Wire) Welder.
 - DC Manual (Stick) Welder.
 - AC Welder with Reduced Voltage Control.
- 3.c. In semiautomatic or automatic wire welding, the electrode, electrode reel, welding head, nozzle or semiautomatic welding gun are also electrically “hot”.
 - 3.d. Always be sure the work cable makes a good electrical connection with the metal being welded. The connection should be as close as possible to the area being welded.
 - 3.e. Ground the work or metal to be welded to a good electrical (earth) ground.
 - 3.f. Maintain the electrode holder, work clamp, welding cable and welding machine in good, safe operating condition. Replace damaged insulation.
 - 3.g. Never dip the electrode in water for cooling.
 - 3.h. Never simultaneously touch electrically “hot” parts of electrode holders connected to two welders because voltage between the two can be the total of the open circuit voltage of both welders.
 - 3.i. When working above floor level, use a safety belt to protect yourself from a fall should you get a shock.
 - 3.j. Also see Items 6.c. and 8.



ARC RAYS CAN BURN.



- 4.a. Use a shield with the proper filter and cover plates to protect your eyes from sparks and the rays of the arc when welding or observing open arc welding. Headshield and filter lens should conform to ANSI Z87.1 standards.
- 4.b. Use suitable clothing made from durable flame-resistant material to protect your skin and that of your helpers from the arc rays.
- 4.c. Protect other nearby personnel with suitable, non-flammable screening and/or warn them not to watch the arc nor expose themselves to the arc rays or to hot spatter or metal.



FUMES AND GASES CAN BE DANGEROUS.



- 5.a. Welding may produce fumes and gases hazardous to health. Avoid breathing these fumes and gases. When welding, keep your head out of the fume. Use enough ventilation and/or exhaust at the arc to keep fumes and gases away from the breathing zone. **When welding with electrodes which require special ventilation such as stainless or hard facing (see instructions on container or MSDS) or on lead or cadmium plated steel and other metals or coatings which produce highly toxic fumes, keep exposure as low as possible and within applicable OSHA PEL and ACGIH TLV limits using local exhaust or mechanical ventilation. In confined spaces or in some circumstances, outdoors, a respirator may be required. Additional precautions are also required when welding on galvanized steel.**
- 5.b. The operation of welding fume control equipment is affected by various factors including proper use and positioning of the equipment, maintenance of the equipment and the specific welding procedure and application involved. Worker exposure level should be checked upon installation and periodically thereafter to be certain it is within applicable OSHA PEL and ACGIH TLV limits.
- 5.c. Do not weld in locations near chlorinated hydrocarbon vapors coming from degreasing, cleaning or spraying operations. The heat and rays of the arc can react with solvent vapors to form phosgene, a highly toxic gas, and other irritating products.
- 5.d. Shielding gases used for arc welding can displace air and cause injury or death. Always use enough ventilation, especially in confined areas, to insure breathing air is safe.
- 5.e. Read and understand the manufacturer’s instructions for this equipment and the consumables to be used, including the material safety data sheet (MSDS) and your employer’s safety practices. MSDS forms are available from your welding distributor or from the manufacturer.
- 5.f. Also see item 1.b.



WELDING AND CUTTING SPARKS CAN CAUSE FIRE OR EXPLOSION.

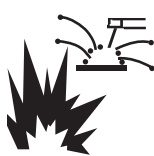

- 6.a. Remove fire hazards from the welding area. If this is not possible, cover them to prevent the welding sparks from starting a fire. Remember that welding sparks and hot materials from welding can easily go through small cracks and openings to adjacent areas. Avoid welding near hydraulic lines. Have a fire extinguisher readily available.
- 6.b. Where compressed gases are to be used at the job site, special precautions should be used to prevent hazardous situations. Refer to "Safety in Welding and Cutting" (ANSI Standard Z49.1) and the operating information for the equipment being used.
- 6.c. When not welding, make certain no part of the electrode circuit is touching the work or ground. Accidental contact can cause overheating and create a fire hazard.
- 6.d. Do not heat, cut or weld tanks, drums or containers until the proper steps have been taken to insure that such procedures will not cause flammable or toxic vapors from substances inside. They can cause an explosion even though they have been "cleaned". For information, purchase "Recommended Safe Practices for the Preparation for Welding and Cutting of Containers and Piping That Have Held Hazardous Substances", AWS F4.1 from the American Welding Society (see address above).
- 6.e. Vent hollow castings or containers before heating, cutting or welding. They may explode.
- 6.f. Sparks and spatter are thrown from the welding arc. Wear oil free protective garments such as leather gloves, heavy shirt, cuffless trousers, high shoes and a cap over your hair. Wear ear plugs when welding out of position or in confined places. Always wear safety glasses with side shields when in a welding area.
- 6.g. Connect the work cable to the work as close to the welding area as practical. Work cables connected to the building framework or other locations away from the welding area increase the possibility of the welding current passing through lifting chains, crane cables or other alternate circuits. This can create fire hazards or overheat lifting chains or cables until they fail.
- 6.h. Also see item 1.c.
- 6.i. Read and follow NFPA 51B "Standard for Fire Prevention During Welding, Cutting and Other Hot Work", available from NFPA, 1 Batterymarch Park, PO box 9101, Quincy, Ma 022690-9101.
- 6.j. Do not use a welding power source for pipe thawing.



CYLINDER MAY EXPLODE IF DAMAGED.



- 7.a. Use only compressed gas cylinders containing the correct shielding gas for the process used and properly operating regulators designed for the gas and pressure used. All hoses, fittings, etc. should be suitable for the application and maintained in good condition.
- 7.b. Always keep cylinders in an upright position securely chained to an undercarriage or fixed support.
- 7.c. Cylinders should be located:
 - Away from areas where they may be struck or subjected to physical damage.
 - A safe distance from arc welding or cutting operations and any other source of heat, sparks, or flame.
- 7.d. Never allow the electrode, electrode holder or any other electrically "hot" parts to touch a cylinder.
- 7.e. Keep your head and face away from the cylinder valve outlet when opening the cylinder valve.
- 7.f. Valve protection caps should always be in place and hand tight except when the cylinder is in use or connected for use.
- 7.g. Read and follow the instructions on compressed gas cylinders, associated equipment, and CGA publication P-1, "Precautions for Safe Handling of Compressed Gases in Cylinders," available from the Compressed Gas Association 1235 Jefferson Davis Highway, Arlington, VA 22202.



FOR ELECTRICALLY POWERED EQUIPMENT.



- 8.a. Turn off input power using the disconnect switch at the fuse box before working on the equipment.
- 8.b. Install equipment in accordance with the U.S. National Electrical Code, all local codes and the manufacturer's recommendations.
- 8.c. Ground the equipment in accordance with the U.S. National Electrical Code and the manufacturer's recommendations.

Refer to <http://www.lincolnelectric.com/safety> for additional safety information.

ELECTROMAGNETIC COMPATIBILITY (EMC)

CONFORMANCE

Products displaying the CE mark are in conformity with European Community Council Directive of 3 May 1989 on the approximation of the laws of the Member States relating to electromagnetic compatibility (2014/30/UE). It was manufactured in conformity with a national standard that implements a harmonized standard: EN 60974-10

Electromagnetic Compatibility (EMC) Product Standard for Arc Welding Equipment. It is for use with other Lincoln Electric equipment. It is designed for industrial and professional use.

INTRODUCTION

All electrical equipment generates small amounts of electromagnetic emission. Electrical emission may be transmitted through power lines or radiated through space, similar to a radio transmitter. When emissions are received by other equipment, electrical interference may result. Electrical emissions may affect many kinds of electrical equipment; other nearby welding equipment, radio and TV reception, numerical controlled machines, telephone systems, computers, etc. Be aware that interference may result and extra precautions may be required when a welding power source is used in a domestic establishment.

INSTALLATION AND USE

The user is responsible for installing and using the welding equipment according to the manufacturer's instructions. If electromagnetic disturbances are detected then it shall be the responsibility of the user of the welding equipment to resolve the situation with the technical assistance of the manufacturer. In some cases this remedial action may be as simple as earthing (grounding) the welding circuit, see Note. In other cases it could involve construction of an electromagnetic screen enclosing the power source and the work complete with associated input filters. In all cases electromagnetic disturbances must be reduced to the point where they are no longer troublesome.

Note: The welding circuit may or may not be earthed for safety reasons according to national codes. Changing the earthing arrangements should only be authorized by a person who is competent to assess whether the changes will increase the risk of injury, e.g., by allowing parallel welding current return paths which may damage the earth circuits of other equipment.

ASSESSMENT OF AREA

Before installing welding equipment, the user shall make an assessment of potential electromagnetic problems in the surrounding area. The following shall be taken into account:

- a. Other supply cables, control cables, signaling and telephone cables; above, below and adjacent to the welding equipment;
- b. radio and television transmitters and receivers;
- c. computer and other control equipment;
- d. safety critical equipment, e.g., guarding of industrial equipment;
- e. the health of the people around, e.g., the use of pacemakers and hearing aids;
- f. equipment used for calibration or measurement and
- g. the immunity of other equipment in the environment. The user shall ensure that other equipment being used in the environment is compatible. This may require additional protection measures including:
- h. the time of day that welding or other activities are to be carried out.

The size of the surrounding area to be considered will depend on the structure of the building and other activities that are taking place. The surrounding area may extend beyond the boundaries of the premises.

METHODS OF REDUCING EMISSIONS

Mains Supply

Welding equipment should be connected to the mains supply according to the manufacturer's recommendations. If interference occurs, it may be necessary to take additional precautions such as filtering of the mains supply. Consideration should be given to shielding the supply cable of permanently installed welding equipment, in metallic conduit or equivalent. Shielding should be electrically continuous throughout its length. The shielding should be connected to the welding power source so that good electrical contact is maintained between the conduit and the welding power source enclosure.

Maintenance of the Welding Equipment

The welding equipment should be routinely maintained according to the manufacturer's recommendations. All access and service doors and covers should be closed and properly fastened when the welding equipment is in operation. The welding equipment should not be modified in any way except for those changes and adjustments covered in the manufacturer's instructions. In particular, the spark gaps of arc striking and stabilizing devices should be adjusted and maintained according to the manufacturer's recommendations.

Welding Cables

The welding cables should be kept as short as possible and should be positioned close together, running at or close to floor level.

Equipotential Bonding

Bonding of all metallic components in the welding installation and adjacent to it should be considered. However, metallic components bonded to the work piece will increase the risk that the operator could receive a shock by touching these metallic components and the electrode at the same time. The operator should be insulated from all such bonded metallic components.

Earthing of the Workpiece

Where the workpiece is not bonded to earth for electrical safety, not connected to earth because of its size and position, e.g., ships hull or building steelwork, a connection bonding the workpiece to earth may reduce emissions in some, but not all instances. Care should be taken to prevent the earthing of the work piece increasing the risk of injury to users, or damage to other electrical equipment. Where necessary, the connection of the workpiece to earth should be made by a direct connection to the work piece, but in some countries where direct connection is not permitted, the bonding should be achieved by suitable capacitance, selected according to national regulations.

Screening and Shielding

Selective screening and shielding of other cables and equipment in the surrounding area may alleviate problems of interference. Screening of the entire welding installation may be considered for special applications.

- 1 Portions of the preceding text are contained in EN 60974-10: "Electromagnetic Compatibility (EMC) product standard for arc welding equipment."

Technical Specifications APEX 30M	A-1
Safety Precautions	A-2
Proper Handling	A-2
Operation.....	A-2
APEX 30M System	B-1
Basic Information.....	B-1
Front Panel.....	B-1
Wire Compartment.....	B-2
Back Panel Connections	B-2
Installation	B-3
System Cart	B-3
Optional Modules	B-3
Power Source.....	B-3
Cart Top Bracket	B-3
APEX 30M.....	B-3
Cart Accessories	B-3
Accessories Installation.....	B-4
Cable Installation.....	B-5
Basic System	B-5
Advanced System	B-5
System Assembly Diagrams	B-6
Shielding Gas Connection.....	B-7
Procedure to Install Wire Guides and Drive Rolls	B-7
Loading Wire	B-8
Pressure Arm Adjustment.....	B-8
Maintenance	D-1
Maintenance Schedule	D-1
Every Shift.....	D-1
Monthly.....	D-1
Using the Status LED to Troubleshoot System Problems	F-1
Weld Head Status LED Error Codes	F-2
Diagrams	G-1
APEX 30M PARTS MANUAL	P-1

Technical Specifications APEX® 30M

APEX 30M Control Unit Product Number K52160-1			
Input Power		40 VDC	
Rated Output		24V 9A	
Input Current		10A Max	
Dimensions L x W x H (in.)		25.33 x 11 x 14.33	
Dimensions L x W x H (mm)		644.4 x 279.4 x 363.2	
Net Weight lbs. (kg)		48.5 (22.0)	
Duty Cycle			
@ 500 Amps		60%	
@ 450 Amps		100%	
GEARING			
GMAW		FCAW	
WFS Range	Wire Sizes	WFS Range	Wire Sizes
50 - 1200 ipm (0.8 - 30.5 m/min)	0.023 - 1/16" (0.6 - 1.6 mm)	50 - 1200 ipm (1.3 -30.5 m/min)	0.035 - 5/64" (0.9 - 2.0 mm)
Temperature Ranges			
Operating Temperature Range 32°F to 122°F (0°C - 50°C)		Storage Temperature Range -22°F to 140°F (-30°C - 60°C)	
A-weighted emission sound pressure level: less than 70 db (A)			

Safety Precautions

Read entire manual before installation or operation.



WARNING

ELECTRIC SHOCK CAN KILL



- Only qualified personnel should perform this installation.
- Turn the input power OFF at the disconnect switch or fuse box before working on this equipment turn off the input power to any other equipment connected to the welding system at the disconnect switch or fuse box before working on the equipment.
- Do not touch electrically hot parts.
- Always connect the power supply grounding lug to a proper safety (Earth) ground.

Proper Handling

Do not attempt to pick up, move or manipulate the control unit by the cables.

Always operate the control unit on stable, flat and level surfaces with the bottom or side rails facing the ground. Be sure to leave adequate room to open the door to the wire feed assembly. Unplug the control unit when not in use. Do not place on wet ground or in puddles.

The system cart is designed for flat even surfaces. Do no overload cart.

Operation

Read entire manual before operation.

Only operate while on firm level surface or attached to a system cart. Always verify that the system cart is secured in place before operation.

Keep hands away from weld head while in operation.



CAUTION

Never unplug or plug in control cables to the tractor while the system is powered on.

Verify that the system is properly grounded before beginning to weld.

Refer to the individual system manuals for additional instructions.

APEX 30M System

Basic Information

The incredibly mobile APEX® 30M Welding System weighs less than 50 lbs and features a convenient handle on top, making it easy to transport and weld in remote locations – see **Figure 1 - APEX 30M**. It functions as both a controller and a wire feeder capable of supporting up to a 44 lb (12 inches diameter) spool.

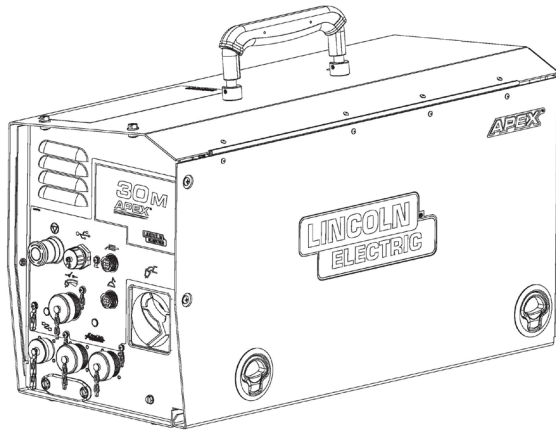

FIGURE 1 - APEX 30M

The APEX 30M Control Unit (K52160-1) is part of the APEX 3 Series family of controls. The control unit manages the welding process from the power supply. All aspects of the weld, i.e., amps, volts, travel speed, oscillation, etc., are synchronized through the APEX 30M.

Combining Lincoln's high-quality weld system with wire feeding capabilities, the APEX 30M has the same functionality as the APEX 3000. Like the APEX 3000, the 30M is one of the three main components every welder needs: an APEX control unit, a HELIX® weld head, and a welding power source.

The status of the system can be monitored on the front panel – see **FIGURE 2 - Front Panel**. Additionally, the front of the control has a halt button, two connections for pendants, a weld head connector, and a USB port.

Front Panel

For all front panel connections – see **FIGURE 2 - Front Panel**.

1. Work Sense Lead Pass Through -

This is an optional connection. By default the work is sensed directly from the power source output studs. For the remote Work Sense lead to be used, a separate Work Sense lead must be connected between the power source and connection 1 on the APEX 30M Back Panel. See **FIGURE 2 - Back Panel on page B-2**.

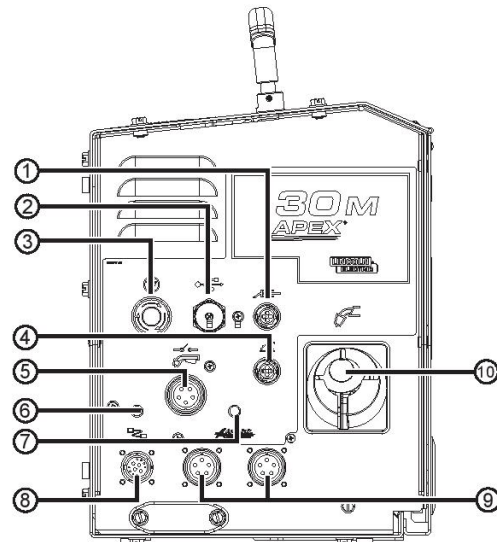

FIGURE 2 - Front Panel

2. **USB** - Welding programs and data can be saved and loaded via USB.
3. **Halt Switch** - Allows operator to remove power from the weld head. The system will remain off until the switch is rotated clockwise. This switch does not shut off the power source or the pendant.
4. **Electrode Sense** - Optional connection for remote Electrode sense.
5. **Trigger Input** - Optional trigger input for manual welding.
6. **Motion Network Status** - The network status light will show green if all motion systems are operational.
7. **ArcLink® Status** - The ArcLink status light will be green if all ArcLink systems are operational.
8. **Weld Head Connector** - Connection from the APEX 30M to the weld head.
9. **ArcLink** - Two ArcLink cable connections for pendants or other ArcLink devices.
10. **Mechanized Torch** - Welding torch passes through the front panel (connected and secured through side panel).

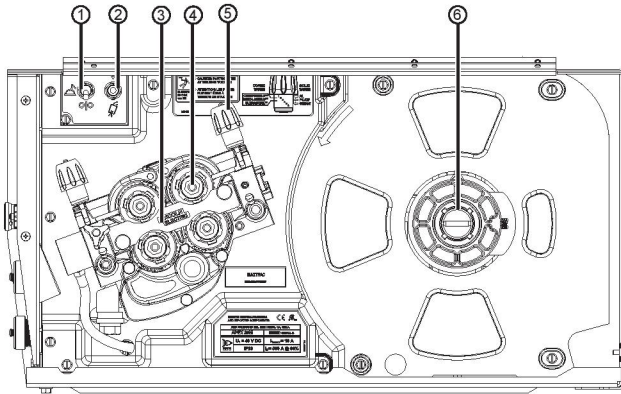

Figure 3 - Wire Compartment

Wire Compartment

For all wire compartment items – see **FIGURE 3 - Wire Compartment**.

1. **Electrode Sense Selection** - Electrode sense can be set to sense from control unit bus bar (Down) or from a remote connection (Up). Sensing from the Control unit bus bar (Down) is the default mode.
If the electrode sense is set to remote (up) there must be a sense lead cable connected to connection 4 on the front panel – see **Figure 2 - Front Panel**.
2. **Cold Feed / Gas Purge Switch** - Allows the operator to cold wire feed (Up) or purge the gas (Down) from the control unit.
3. **Outer Wire Guide** - Removable outer wire guide for easy access to change drive rolls.
4. **Drive Rolls** - Standard drive rolls available in many sizes for different applications.
5. **Pressure Arms** - Allows pressure of the drive rolls on the wire to be adjusted by hand.
6. **Spindle** - Spindle designed for 10 lb (4.5 kg) to 44 lb (20 kg) spools with a 12”(305 mm) spool diameter.

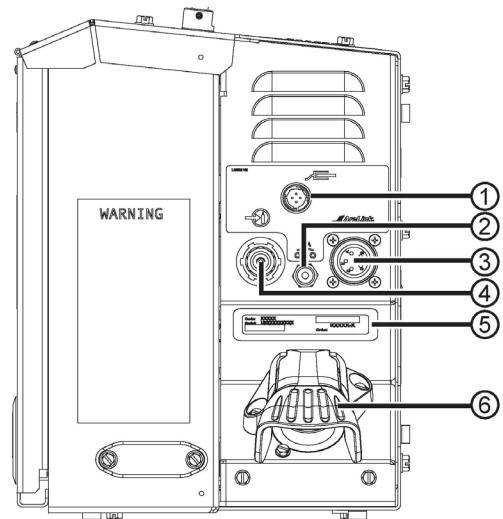

Figure 4 - Back Panel

Back Panel Connections

For all bank panel connections – see **FIGURE 4 - Back Panel**.

1. **Work Sense Lead Pass Through** - Used when the work sense lead signal is passing through the APEX 30M. This connection is optional and must be used in conjunction with a Work Sense lead connected to connection 1 on the APEX 30M front panel – see **FIGURE 2 - Front Panel on page B-1**.
2. **Breaker 10A** - Will trip in overpower situations; push to re-engage.
3. **ArcLink In** - The ArcLink connection from the power source or other ArcLink enabled device.
4. **Gas Input** - Welding gas supplied to the system.
5. **Serial Number Label** - Contains part number, serial number and code number of the machine.
6. **Weld Cable Connection** - Connection supplies welding power to the mechanized torch.

Installation

On a standard 30M system, the system components are designed to be installed on the system cart in a specific order. Refer to **FIGURE 5 - System Assembly** for reference.

System Cart

The system cart (K52166-1) comes fully assembled when ordered as a part of a complete system. If ordered separately, it may require additional assembly. Please refer to system cart assembly instructions for complete step-by-step instructions.

Optional Modules

The optional modules are installed in the cart before the power source. Set the module into the mounting holes provided and push backwards to seat the module.

Install the bracket to lock the module in place.

Optional modules have brackets in the top to support the power sources.

Power Source

The power source will be installed either onto the base or on top of the optional modules (if installed). Set the power source into the mounting holes provided and push backwards to seat the module.

Once the unit is in place, remove the front and back handles from the Power Wave® power source. The top bracket of the system cart uses these mounting holes from the Power Wave handles. Screw the handles removed from the Power Wave into the mating holes on the top bracket of the system cart.

Cart Top Bracket

To affix the Power Wave power source in place, attach the top bracket of the cart. Adjust the sliding back brace of the cart so that it is in line with the cart top. Verify that the cart top lines up with both the screw holes on the sliding back brace and the holes from the handles removed earlier. Secure the top bracket in place.

With the top bracket secured in place, attach the handle from the front of the power supply to the front of the cart top bracket into the holes provided. This eases the mobility of the system and offers a convenient holder for the system pendant.

APEX 30M

Once all other components are secured in place, the APEX 30M can be installed onto the top bracket of the system cart. There are channels provided to help guide the APEX 30M into place.

Slide the APEX 30M controller back until the rear of the controller is secured under the catch, and the latch has locked into place. Refer to **FIGURE 5 - System Assembly**

1. **Catch** - Holds the rear of the control in place
2. **Latch** - Latches onto the front of the control to hold it in place. Pull on the latch to disengage.

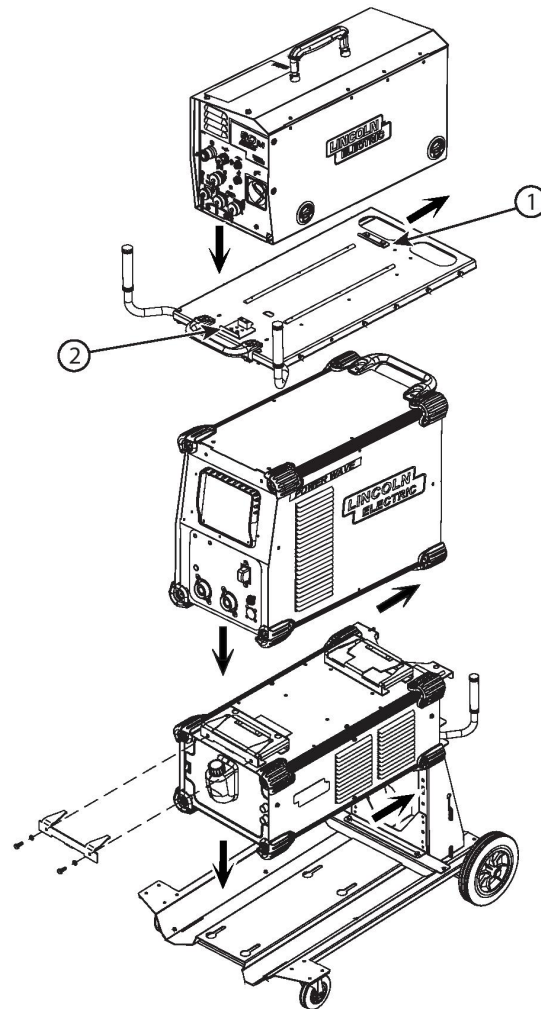

Figure 5 - System Assembly

Cart Accessories

The system cart includes configurable accessories, which are screwed into the side of the cart top bracket as required by the customer. See **FIGURE 6 - Cart Accessories** – for all the accessories.

These items include:

1. **Tractor Hook (1)** - Holds the tractor in place, includes pads and a backing to prevent the weld head from swinging during transportation.

- 2. **Hook (3)** - Holds cables or track rings.
- 3. **Trays (2)** - Holds lightweight system consumables like tips and nozzles, etc.

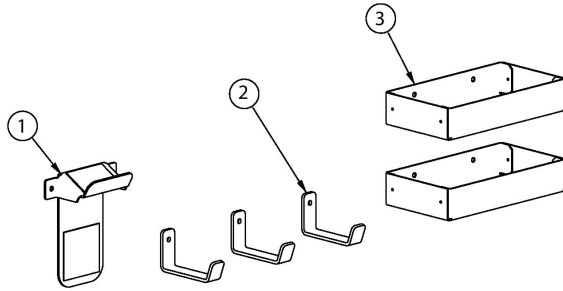

Figure 6 - Cart Accessories

FIGURE 7 - Accessories Installation – shows how the accessories mount to the cart top bracket, using the provided screws into the mating mounting holes. Utilization and location of accessories is up to the user.

Note: To prevent the Power Wave power source from overheating, do not block the side or rear vents while in operation.

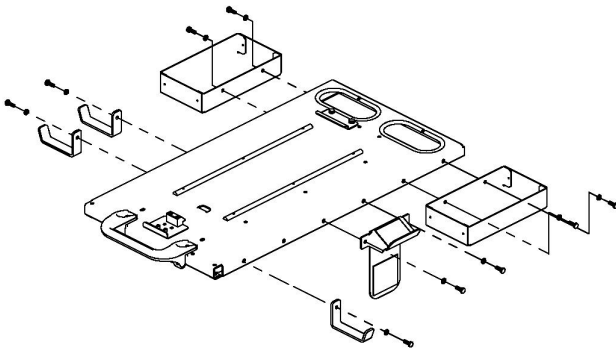

Figure 7 - Accessories Installation

Once the entire system is fully assembled it should look similar to **FIGURE 8 - System Complete**. The system illustrated below includes the optional Advanced Module.

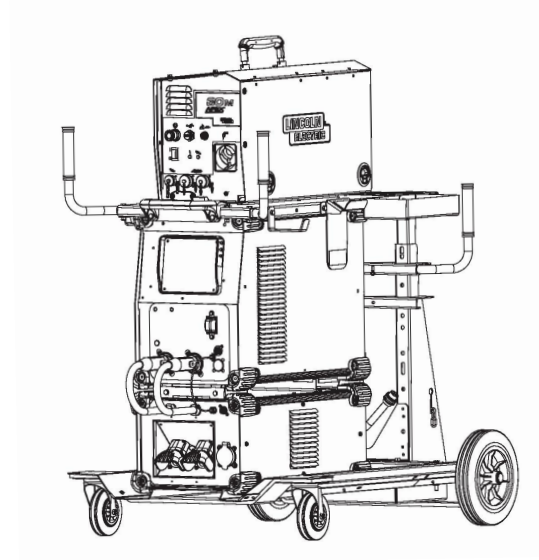

Figure 8 - System Complete

Cable Installation

The system is shipped out with cables connected, however the components can be ordered separately and installed by the operator, or the cables and components may be removed during routine maintenance. For the complete system cable map – see **FIGURE 9 - System Assembly**.

Note:

- Always use the shortest cable lengths possible. DO NOT coil excess cable. It is recommended that the total length of control cable does not exceed 100' (30.5M). The use of non-standard cables in excess of 25' (7.5M) can lead to communication problems (system shutdowns), poor motor acceleration (poor arc starting), and low wire driving force (wire feeding problems).
- Best results will be obtained when the control cables are routed separate from the weld cables. This minimizes the possibility of interference between the high currents flowing through the weld cables and the low level signals in the control cables.:

ARCLINK cables can be used to extend the pendant cable length.

Standard Lincoln Cables		
Torch & Cables	Part Number	Location #
Pendant Cable 25'	K52130-25	1
Pendant Cable 15'	K52130-15	1
Control Cable 15 ft. (4.6 m)	K52107-15	2
Control Cable 25 ft. (7.6 m)	K52107-25	2
Mechanized Torch 25 ft. (7.6 m)	K52106-1	3
Mechanized Torch 15 ft. (4.6 m)	K52106-2	3
Weld Power Cable 10'	K1824-10	4/5
Weld Power Cable 35'	K1824-35	4/5
Weld Power Cable 60'	K1824-60	4/5
Weld Power Cable 110'	K1824-110	4/5
Sense Lead	M20023-1	6
Arclink Cable 8'	K1543-8	7
Arclink Cable 25'	K1543-25	7
Arclink Cable 50'	K1543-50	7
Arclink Cable 100'	K1543-100	7

Basic System

1. **Pendant Cable** - Connects from the pendant to the control unit
2. **Control Cable** - Connects from the weld head to the control unit
3. **Mechanized Torch** - Runs from the control unit out to the weld head
4. **Electrode Cable** - Connects from the positive stud on the POWER WAVE (or Advanced Process Module if installed) to the rear of the control unit
5. **Work Cable*** - Connects from the negative stud of the POWER WAVE (or Advanced Process Module if installed) to the work piece
6. **Sense Lead*** - Optional sense lead, can extend from the POWER WAVE to the work piece
7. **ARCLINK Cable** - Connects from the power supply to the control unit
8. **3-Phase Power Cable*** - Connects power supply to facility power (refer to power supply manual for installation)
9. **Gas Hose*** - Supplies gas to the system from external source
10. **Ethernet Cable*** - Optional cable to connect the power supply to a local area network for added system functionality

Advanced System

11. **Sense Lead Pigtail** - Comes as part of the Advanced Process Module, allows sensing from the new module
12. **Arclink Pigtail** - Comes as part of the Advanced Process Module, connects to the power supply

** Indicates items not included with the system*

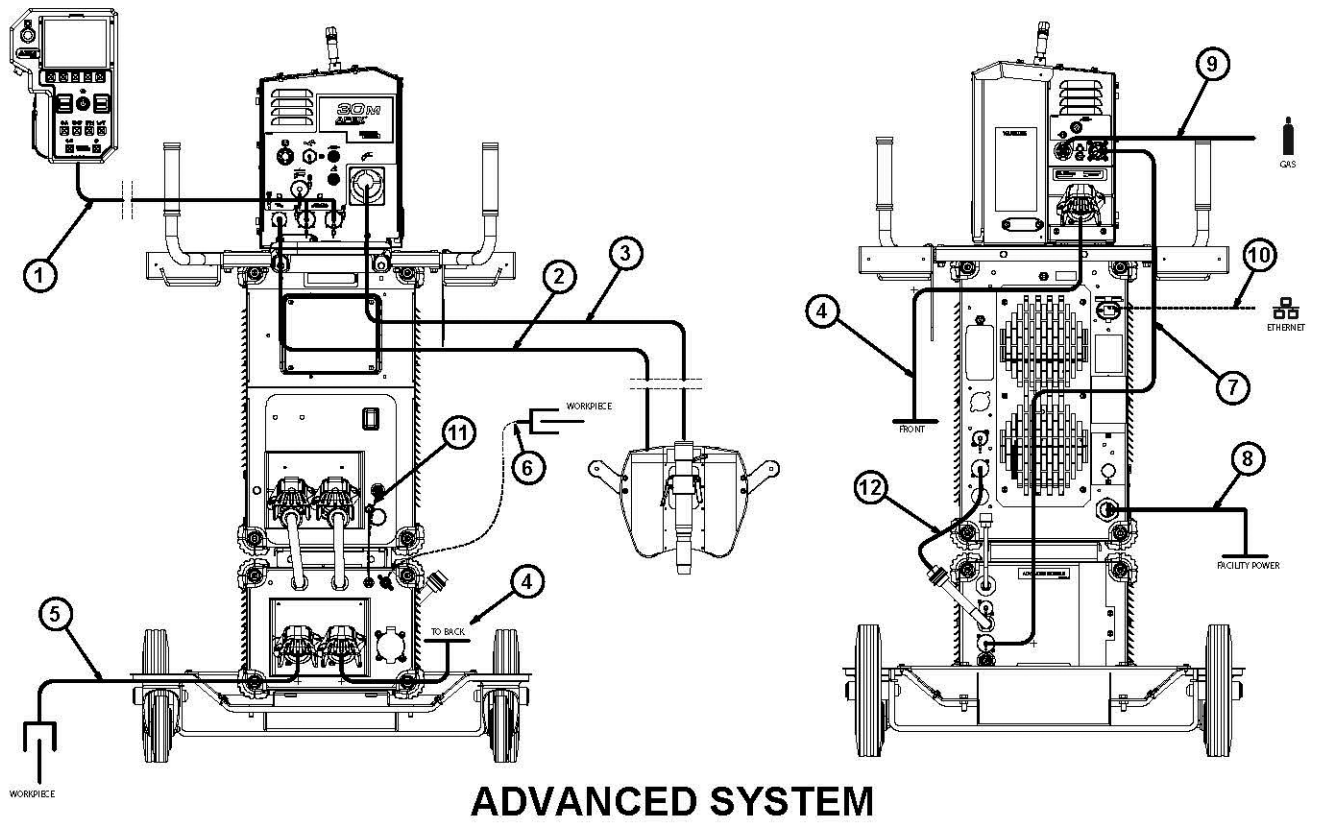
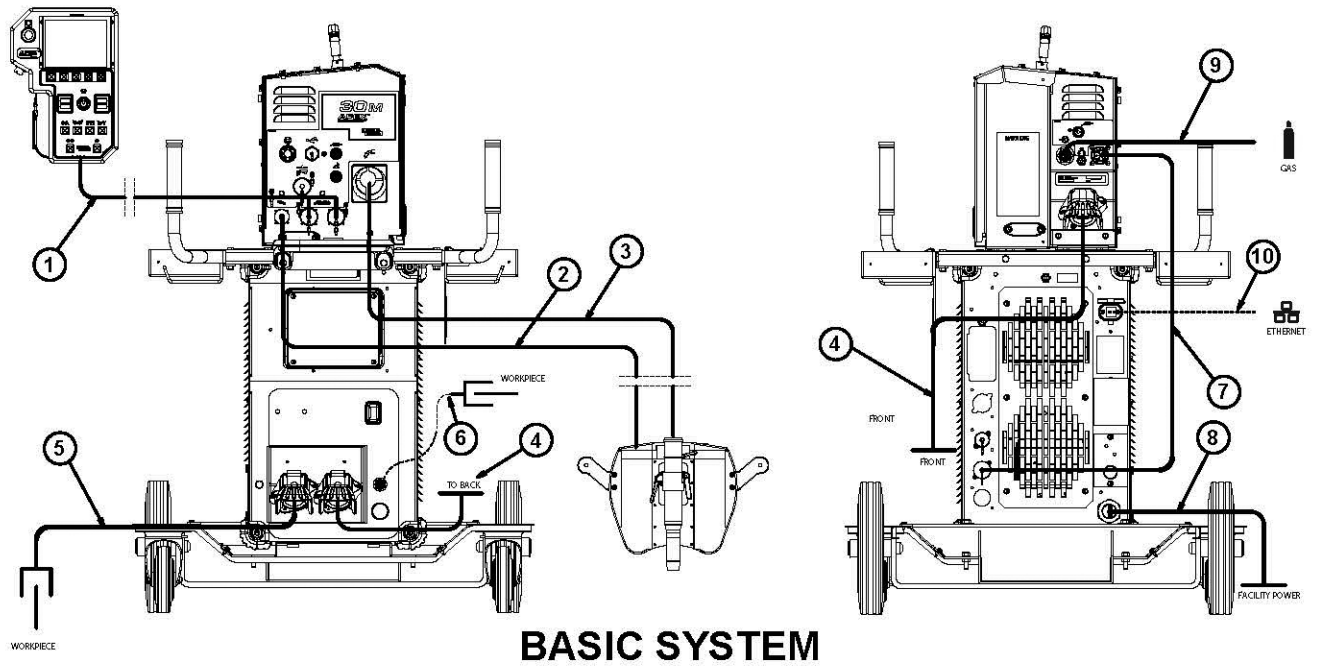

FIGURE 9 - System Assembly

Shielding Gas Connection

WARNING



CYLINDER MAY EXPLODE IF DAMAGED.

- Keep cylinder upright and chained to support.
- Keep cylinder away from areas where it may be damaged.
- Never lift welder with cylinder attached.
- Never allow welding electrode to touch cylinder.
- Keep cylinder away from welding or other live electrical circuits.
- **THE BUILD UP OF SHIELDING GAS MAY HARM HEALTH OR KILL.**



- Shut off shielding gas supply when not in use.
- See American National Standard Z-49.1, "Safety in Welding and Cutting" Published by the American Welding Society.

MAXIMUM INLET PRESSURE IS 100 PSI. (6.9 BAR.)

Install the shielding gas supply as follows:

1. Secure the cylinder to prevent it from falling.
2. Remove the cylinder cap. Inspect the cylinder valves and regulator for damaged threads, dirt, dust, oil or grease. Remove dust and dirt with a clean cloth. **DO NOT ATTACH THE REGULATOR IF OIL, GREASE OR DAMAGE IS PRESENT!** Inform your gas supplier of this condition.
3. Stand to one side away from the outlet and open the cylinder valve for an instant. This blows away any dust or dirt which may have accumulated in the valve outlet.
4. Attach the flow regulator to the cylinder valve and tighten the union nut(s) securely with a wrench.

Note: if connecting to 100 percent CO₂ cylinder, insert regulator adapter between regulator and cylinder valve. If adapter is equipped with a plastic washer, be sure it is seated for connection to the CO₂ cylinder.

5. Attach one end of the inlet hose to the outlet fitting of the flow regulator. Attach the other end to the welding system shielding gas inlet. Tighten the union nuts with a wrench.
6. Before opening the cylinder valve, turn the regulator adjusting knob counterclockwise until the adjusting spring pressure is released.
7. Standing to one side, open the cylinder valve slowly a fraction of a turn. When the cylinder pressure gage stops moving, open the valve fully.
8. The flow regulator is adjustable. Adjust it to the flow rate recommended for the procedure and process being used before making a weld.

Procedure to Install Wire Guides and Drive Rolls

WARNING

ELECTRIC SHOCK can kill.



- Turn the input power **OFF** at the welding power source before installation or changing drive rolls and/or guides.
- Do not touch electrically live parts.
- When inching with the gun trigger, electrode and drive mechanism are "hot" to work and ground and could remain energized several seconds after the gun trigger is released.
- Do not operate with covers, panels or guards removed or open.
- Only qualified personnel should perform maintenance work.

To remove drive rolls and wire guides:

1. Turn power off at the welding power source.
2. Remove the outer wire guide.

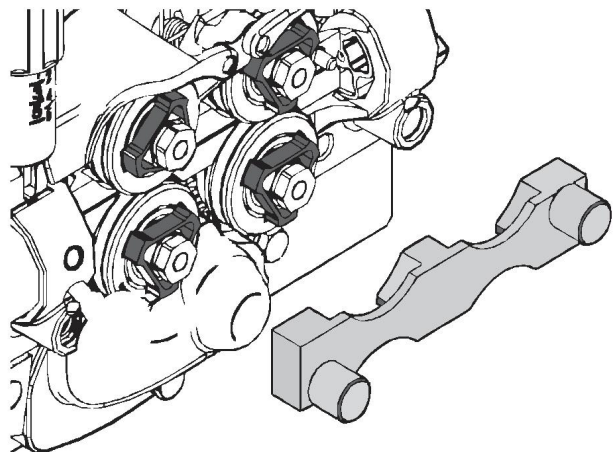

3. Rotate all of the triangular rings to the unlocked position.

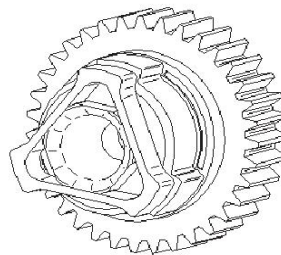

UNLOCKED POSITION

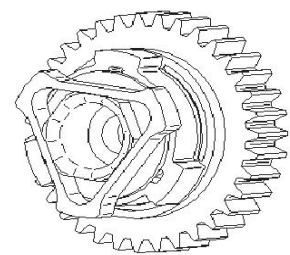

LOCKED POSITION

4. Open the idle arms.
5. Remove the drive rolls and inner wire guide.

To install drive rolls and wire guides:

1. Turn off power at the welding power source.
2. Open the idle arms.
3. Assemble the inner wire guide.

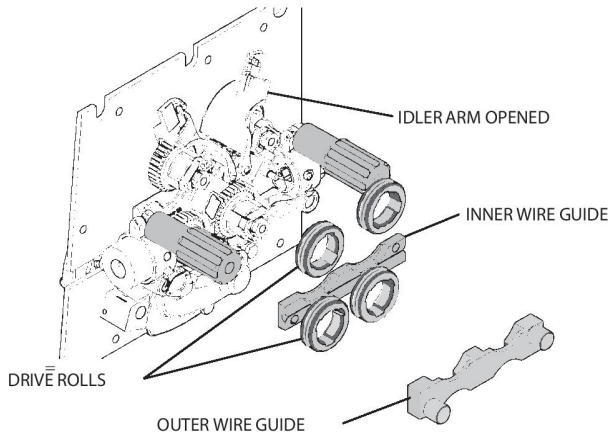

4. Slide the drive rolls onto the drive hubs.
5. Close the idle arms.
6. Rotate all of the triangular rings to the locked position.
7. Assemble the outer wire guide.
8. Adjust the pressure arms to the recommended setting.

Pressure Arm Adjustment

⚠ WARNING

ELECTRIC SHOCK can kill.



- Turn the input power OFF at the welding power source before installation or changing drive rolls and/or guides.
- Do not touch electrically live parts.
- When inching with the gun trigger, electrode and drive mechanism are “hot” to work and ground and could remain energized several seconds after the gun trigger is released.

- Do not operate with covers, panels or guards removed or open.
- Only qualified personnel should perform maintenance work.

The Pressure Arm – see **FIGURE 5 - Pressure Arm** – controls the amount of force the drive rolls exert on the wire. Proper adjustment of the pressure arm gives the best welding performance.

Set the Pressure Arm as follows:

- Aluminum wires between 1 and 3
- Cored Wires between 3 and 4
- Steel, Stainless wires between 4 and 6



FIGURE 1 - Pressure Arm

Loading Wire

⚠ WARNING



- Keep hands, hair, clothing and tools away from rotating equipment
- Do not wear gloves when threading wire or changing wire spool.
- Only qualified personnel should perform maintenance work.

Maintenance

The APEX30M Control System is designed for trouble-free operation and normally requires minimal preventive care and cleaning. This section provides instructions for maintaining user serviceable items. The suggested repair procedure for all such items is to remove and replace defective assemblies or parts. When users and/or service personnel are not familiar with electrical and electronic equipment, the product should be returned to the factory or serviced by factory authorized representatives.

Maintenance Schedule

The maintenance schedule is suggested as a guideline for proper system maintenance. More stringent maintenance requirements may be required depending on the work being performed and the requirements of the customer for whom the work is performed. All maintenance schedules are based on a 40-hour work week.

Any excess play in parts or equipment should be noted and reported to an authorized repair facility. Any anomalous activity, such as motor hesitation, clicking or other noises, or anything out of the ordinary should be noted and reported to an authorized repair facility.

Every Shift

- Check lines, cables, and hoses for loose connections and worn areas.
- Change out consumables as needed.

Monthly

- Examine all cable connections to verify that there are no gas leaks. Make sure all cables are seated correctly and that there is no visible wear and tear to any connector or associated cables.
- Check for wear of drive rolls on wire feeder.

Observe all Safety Guidelines detailed throughout this manual

Using the Status LED to Troubleshoot System Problems

The APEX 30M and POWER WAVE are equipped with status LED. If a problem occurs, it is important to note the condition of the status LED – see **FIGURE 2 - Front Panel, item 7 on page B-1**. Before cycling power to the system, check the power source status LED for error sequences as noted below.

Included in this section is information about the Weld Head and ARCLINK status LEDs and a basic troubleshooting chart for both the machine and the weld performance. The LEDs are dual-colored and indicate system errors. Normal operation for each is steady green. Error conditions are indicated in **FIGURE 6 - Status LED Light Conditions**.

FIGURE 2 - Status LED Light Conditions

LIGHT CONDITION	MEANING
Steady Green	System is OK. The power source is operational and is communicating normally with all peripheral equipment connected to its ArcLink network.
Blinking Green	Occurs during power up or a system reset and indicates the Power Wave is mapped (identifying) each component in the system. This is normal for the first 1 to 60 seconds after the power is turned on, or if the system configuration is changed during operation.
Fast Blinking Green	Under normal conditions it indicates that Auto-mapping has failed. It is also used by Weld Manager Utilities. More information is available on the Service Navigator CDs or visit www.powerwavesoftware.com .
Alternating Red and Green	<p>Non-recoverable system fault. If the status lights are flashing any combination of red and green, errors are present. Read and note the error code(s) before turning off the machine.</p> <p>Error code interpretation through the status light is detailed in the service manual. Individual code digits are flashed in red with a long pause between digits. If more than one code is present, the codes will be separated by a green light. Only active error conditions are accessible through the status light.</p> <p>Error codes can also be retrieved with the Weld Manager Utility, included on the Service Navigator CDs. For the most updated error code log information, please visit: www.powerwavesoftware.com.</p> <p>To clear the active error(s), turn the power source off and back on to reset the system.</p>
Steady Red	Not applicable.
Blinking Red	Not applicable.

⚠ CAUTION

If for any reason you do not understand the test procedures or are unable to perform the tests/repairs safely, contact your **Local Lincoln Authorized Field Service Facility** for technical troubleshooting assistance before you proceed.

Observe all Safety Guidelines detailed throughout this manual

Weld Head Status LED Error Codes

Error ID	Description	Potential Solution
5-3-1	Weld head network not recognized by controller. Weld head has no power.	Check to make sure the weld head cable is plugged in and that the APEX 30M controller has power via 110V AC aux connector (if applicable). Cycle power to POWER WAVE.
5-3-3	Communication with oscillation motor has halted.	Check weld head cable for potential bad connections. Cycle power.
5-3-4	Communication with height motor has halted.	Check weld head cable for potential bad connections. Cycle power.
5-3-5	Communication with travel motor has halted.	Check weld head cable for potential bad connections. Cycle power.
5-3-6	Calibrated fault with oscillation	Check weld head cable and cycle power.
5-3-7	Calibrated fault with height	Check weld head cable and cycle power.
5-3-8	Wire drive timeout	Check weld head cable and cycle power.
5-3-9	“Other”	Cycle power.
5-3-6	Calibrated fault with oscillation	Check weld head cable and cycle power.
5-3-7	Calibration fault with height	Check weld head cable and cycle power.
5-3-8	Wire drive timeout	Check weld head cable and cycle power.
5-3-9	“Other”	Cycle power.
5-4-1	Oscillation motor following error	Check for resistance on the torch arm. Oscillation speeds too high.
5-4-2	Oscillation motor overcurrent	Check power supplies, cycle power. Clear any resistance/debris from track and the weld head arm.
5-4-3	Oscillation motor overheat	Check welding conditions. Turn off power for 5 minutes.
5-4-4	Oscillation communications fault	Check weld head cable and make sure no extra power/noise is being discharged into the weld head.
5-4-5	Oscillation communications off	Check weld head cable and make sure no extra power/noise is being discharged into the weld head.
5-4-6	Oscillation was moved passed programmed limit	Recalibrate the system/cycle power. Make sure weld head arm moves all the way in and you have full range of movement.
5-4-7	Oscillation motor overvoltage	Check power supplies, cycle power. Clear any resistance/debris from track and the weld head arm.
5-4-8	Oscillation motor position sensor error	Cycle power. Make sure internal motor controller wire harnesses and connectors are secure.
5-4-9	Oscillation fault unknown	Check all of the above items. Cycle power. Contact a Service Representative at: 800-770-0063

CAUTION

If for any reason you do not understand the test procedures or are unable to perform the tests/repairs safely, contact your **Local Lincoln Authorized Field Service Facility** for technical troubleshooting assistance before you proceed.

Observe all Safety Guidelines detailed throughout this manual

5-5-1	Height motor following error	Check for resistance on the torch arm. Height movement speeds too high.
5-5-2	Height motor overcurrent	Check power supplies. Cycle power. Clear any debris from the track and the weld head arm.
5-5-3	Height motor overheat	Check welding conditions. Turn off power for 5 minutes.
5-5-4	Height communications fault	Check weld head cable and make sure no extra power/ noise is being discharged into the weld head.
5-5-5	Height communications off	Check weld head cable and make sure no extra power/ noise is being discharged into the weld head.
5-5-6	Height was moved passed programmed limit	Recalibrate the system/cycle power. Make sure weld head arm moves all the way in and you have full range of movement. Check Setup.
5-5-7	Height motor overvoltage	Check power supplies, cycle power. Clear any resistance/ debris from track and the weld head arm.
5-5-8	Height motor position sensor error	Cycle power. Make sure internal motor controller wire harnesses and connectors are secure.
5-5-9	Height fault unknown	Check all of the above items; cycle power. Contact a Service Representative at 800-770-0063 .
5-6-1	Travel motor following error	Check for resistance on the torch arm. Travel speeds too high.
5-6-2	Travel motor overcurrent	Check power supplies, cycle power. Clear any resistance/ debris from track and the weld head arm.
5-6-3	Travel motor overheat	Check welding conditions. Turn off power for 5 minutes.
5-6-4	Travel communications fault	Check weld head cable and make sure no extra power / noise is being discharged into the weld head.
5-6-5	Travel communications off	Check weld head cable and make sure no extra power / noise is being discharged into the weld head.
5-6-6	Travel was moved passed programmed limit	Recalibrate the system/cycle power. Make sure you can jog travel along your track.
5-6-7	Travel motor overvoltage	Check power supplies, cycle power. Clear any resistance/ debris from track and the weld head arm.
5-6-8	Travel motor position sensor error	Cycle power. Make sure internal motor controller wire harnesses and connectors are secure.
5-6-9	Travel fault unknown	Check all of the above items. Cycle Power. Contact a Service Representative at the number on the cover of this manual.
5-7-1	Wire motor following error	Check for resistance when pulling wire through the liner. Wire speeds too high.
5-7-2	Wire motor overcurrent	Check power supplies, cycle power. Check for wire bird-nest. Check for resistance when pulling wire through the liner.
5-7-3	Wire motor overheat	Check welding conditions. Turn off power for 5 minutes. Check for resistance when pulling wire through the liner.
5-7-4	Wire communications fault	Check Weld head cable and make sure no extra power / noise is being discharged into the Weld head.
5-7-5	Wire communications off	Check Weld head cable and make sure no extra power / noise is being discharged into the Weld head.

⚠ CAUTION

If for any reason you do not understand the test procedures or are unable to perform the tests/repairs safely, contact your **Local Lincoln Authorized Field Service Facility** for technical troubleshooting assistance before you proceed.

Observe all Safety Guidelines detailed throughout this manual

5-7-6	Wire motor / encoder issue	Cycle power to the system and allow the system to recalibrate. Make sure you can jog wire in Jog mode.
5-7-7	Wire motor overvoltage	Check power supplies, cycle power. Check for wire bird-nest. Check for resistance when pulling wire through the liner.
5-7-8	Wire motor / encoder issue	Cycle power to the system and allow the system to recalibrate. Make sure you can jog wire in Jog mode.
5-7-9	Wire fault unknown	Check all of the above items. Cycle Power. Contact a Service Representative at: 800-770-0063 .
6-3-3-1	Unstable or “noisy” WFS feedback signal	Check the cables and connections. Cycle power.
8-1	Motor Overload (Long Term)	Check the electrode feeds easily through feed system. Verify the wire reel bracket is not too tight. Verify the quality of electrode. We recommend only Lincoln Electric brand..
8-2	Motor Overload (Short Term)	Check that motor can turn freely when idle arm is open. Check gears for dirt and debris. Check for error 8.1.
8-3	Shutdown #1 is open	Contact a Service Representative at: 800-770-0063 .
8-4	Shutdown #2 is open	Contact a Service Representative at 800-770-0063 .

⚠ CAUTION

If for any reason you do not understand the test procedures or are unable to perform the tests/repairs safely, contact your **Local Lincoln Authorized Field Service Facility** for technical troubleshooting assistance before you proceed.

Wiring Diagram 12675

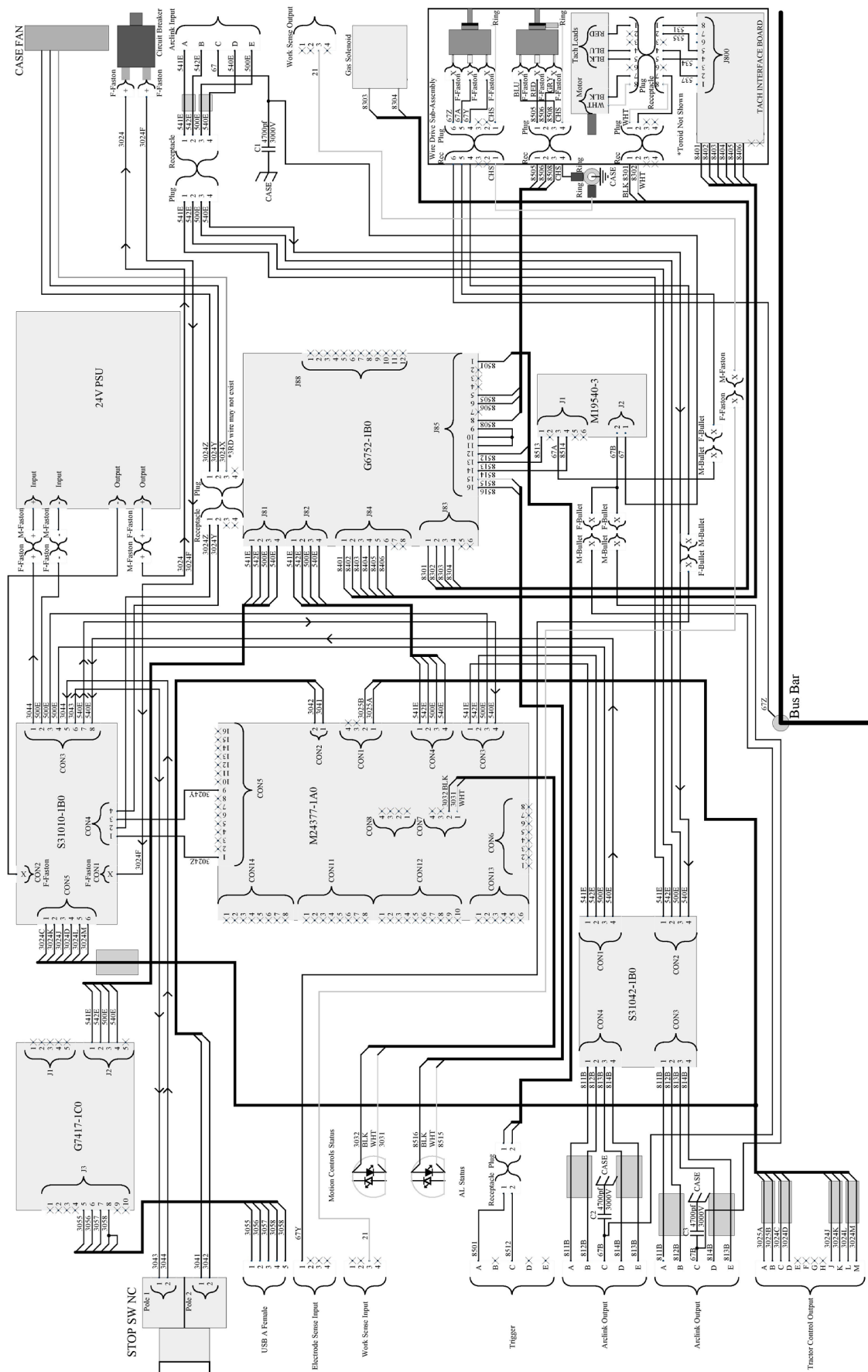

NOTE: This diagram is for reference only. It may not be accurate for all machines covered by this manual. If the diagram is illegible, write to the Service Department for a replacement. Give the equipment code number.

Wiring Diagram 12860

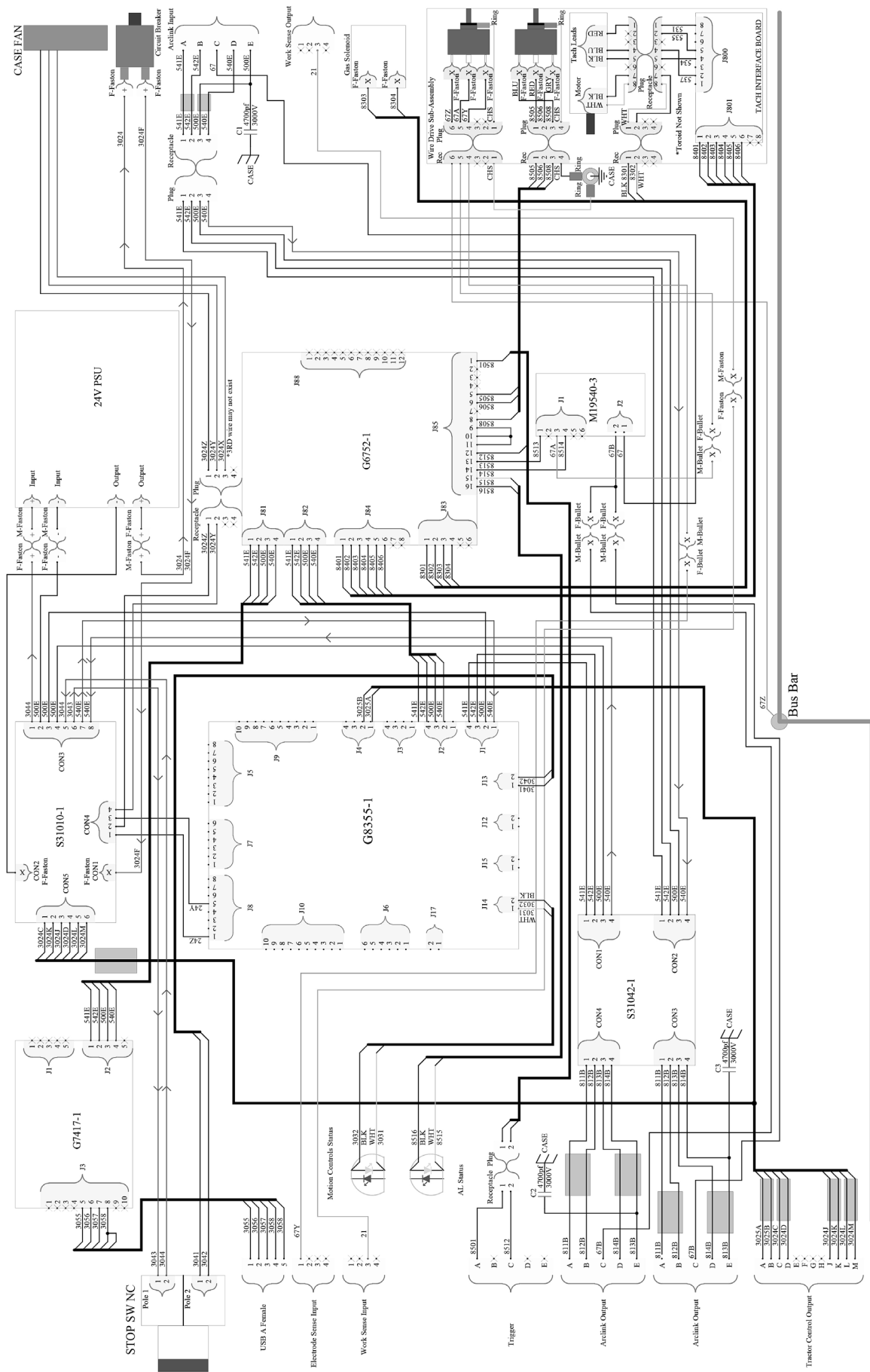

NOTE: This diagram is for reference only. It may not be accurate for all machines covered by this manual. If the diagram is illegible, write to the Service Department for a replacement. Give the equipment code number.

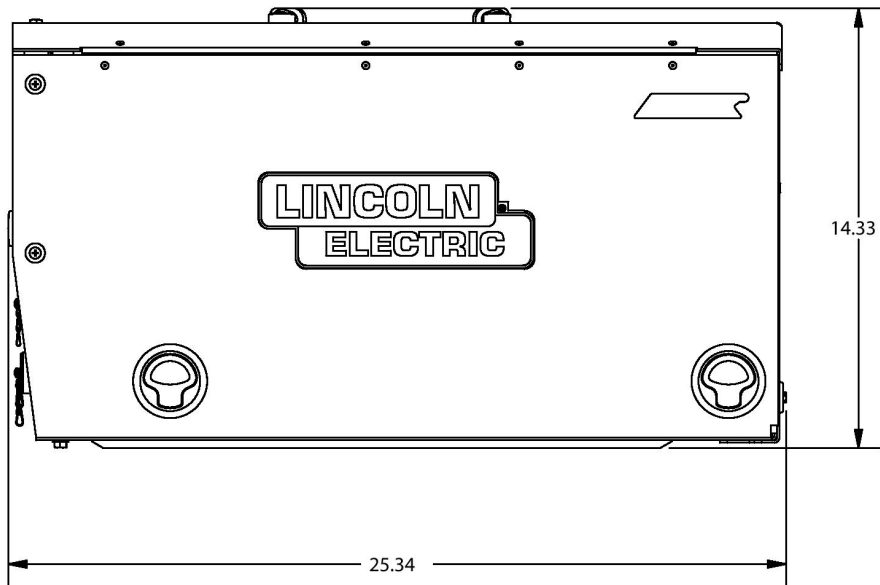
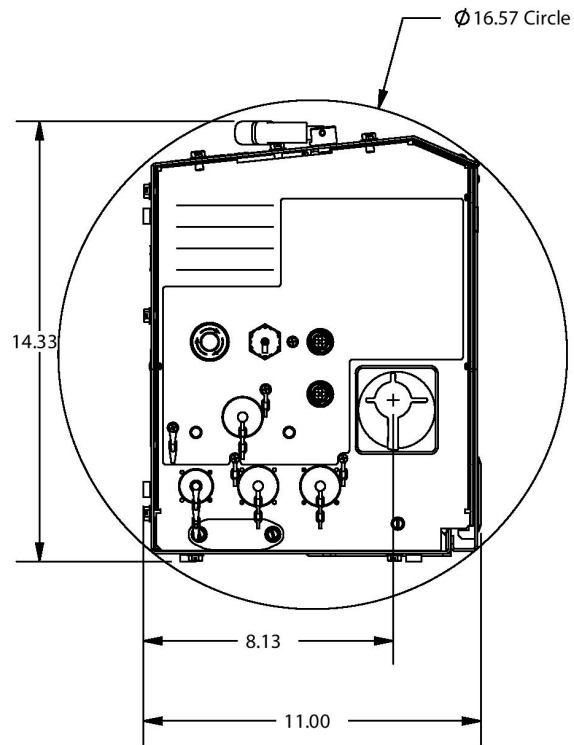

APEX® 30M Controller Dimensions

WEEE

<p>English</p> 	<p style="text-align: right;">07/06</p> <p>Do not dispose of electrical equipment together with normal waste! In observance of European Directive 2002/96/EC on Waste Electrical and Electronic Equipment (WEEE) and its implementation in accordance with national law, electrical equipment that has reached the end of its life must be collected separately and returned to an environmentally compatible recycling facility. As the owner of the equipment, you should get information on approved collection systems from our local representative. By applying this European Directive you will protect the environment and human health!</p>
--------------------------------------------------------------------------------------------------	--------------------------------------------------------------------------------------------------------------------------------------------------------------------------------------------------------------------------------------------------------------------------------------------------------------------------------------------------------------------------------------------------------------------------------------------------------------------------------------------------------------------------------------------------------------------------------------------------------------------------------------------------------------

APEX® 30M PARTS MANUAL

This parts list is provided as an informative guide only.

CODE 12675,12860, 70313, 12833, 12834
INDEX OF SUB ASSEMBLIES

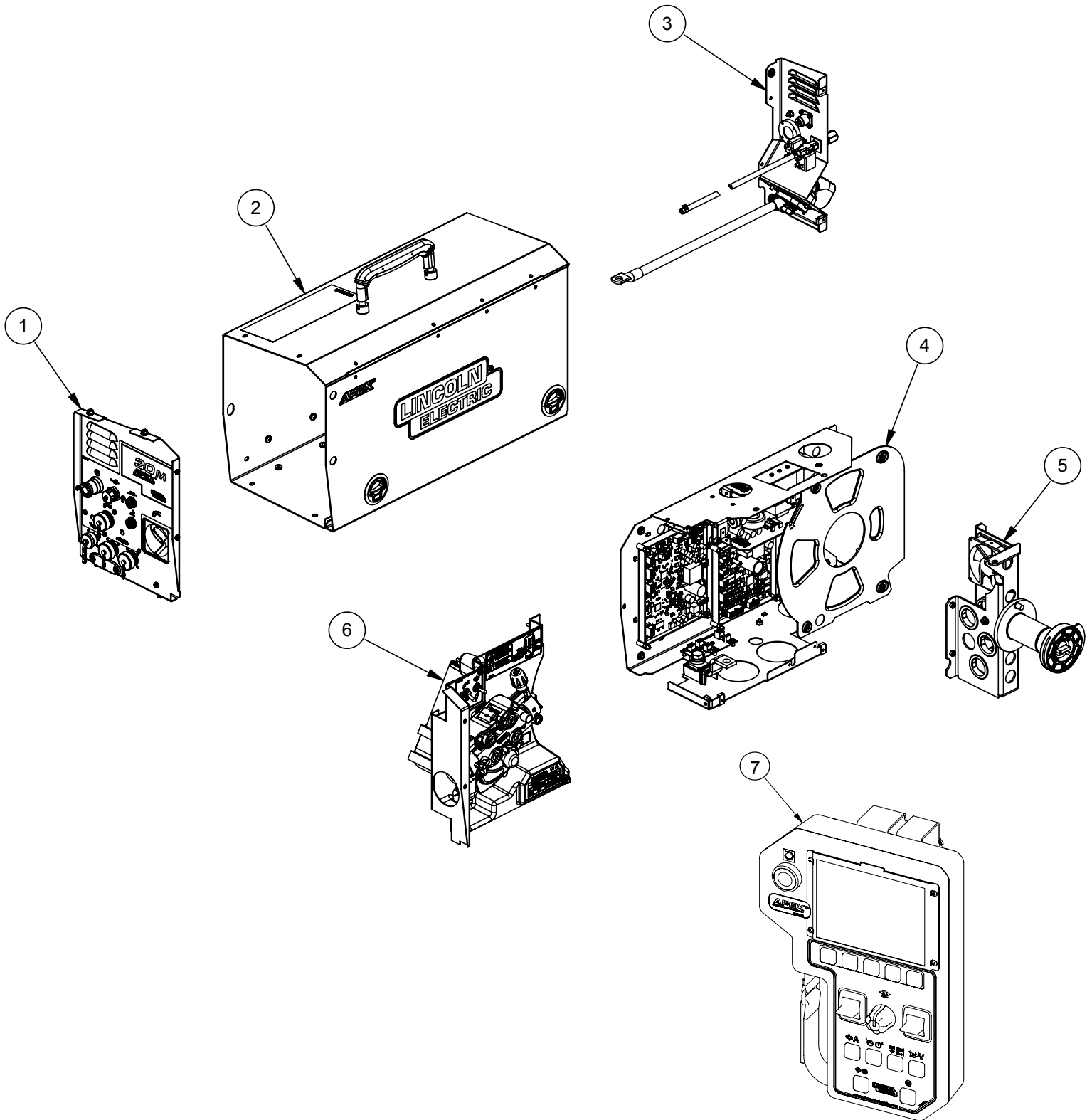

NOTE: This Parts Manual is provided as an informative guide only. When ordering parts always refer to the Lincoln Electric Parts List.

APEX® 30M CONTROL

GENERAL ASSEMBLY

For Codes:12675, 12860, 70313, 12833, 12834

Do not use this Parts List for a machine if its code number is not listed. Contact the Service Department for any code numbers not listed.

Use the illustration of Sub-Assemblies page and the table below to determine which sub assembly page and column the desired part is located on for your particular code machine.

Sub Assembly Item Number	1	2	3	4	5	6		7	
SUB ASSEMBLY PAGE NAME	Front Panel Assembly	Case Assembly	Rear Panel Assembly	Control Box Assembly	Spindle and Mast Assembly	Wire Drive Assembly		Wire Harnesses	APEX 3 Series Pendant
PAGE NO.	P-4	P-6	P-8	P-10	P-12	P-14		P-18	P-20
CODE NO.									
12675	1	1	1	1	1	1		1	•
12860	1	1	1	2	1	1		2	•
70313	•	•	•	•	•	•		•	1
12833	•	•	•	•	•	•		•	2
12834	•	•	•	•	•	•		•	3

NOTE: This Parts Manual is provided as an informative guide only. When ordering parts always refer to the Lincoln Electric Parts List.

FRONT PANEL ASSEMBLY

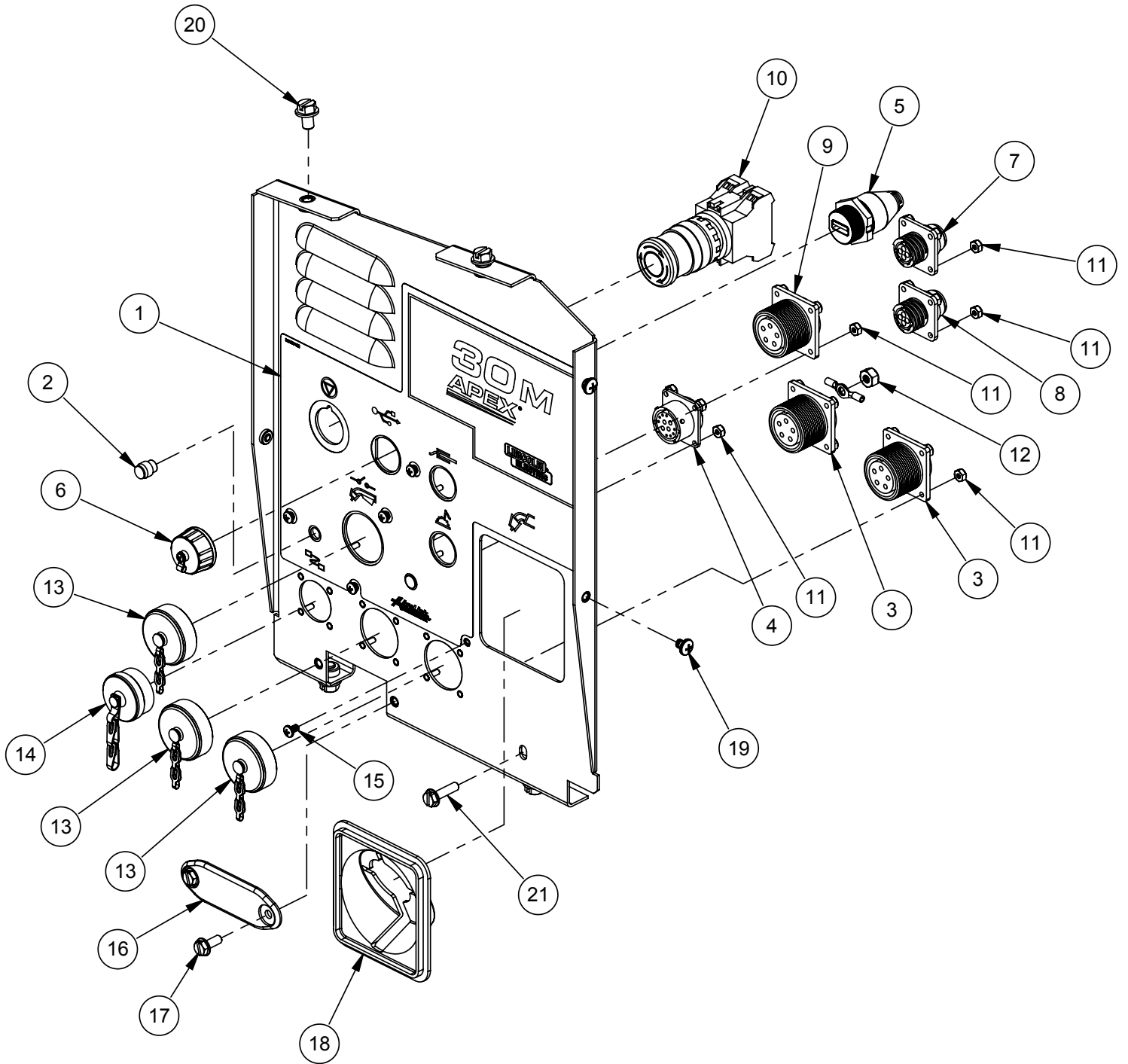

NOTE: This Parts Manual is provided as an informative guide only. When ordering parts always refer to the Lincoln Electric Parts List.

FRONT PANEL ASSEMBLY

Indicates a change in this printing.

Use only the parts marked "x" in the column under the heading number called for in the model index page.

ITEM	DESCRIPTION	PART NO.	QTY	1
1	Front Decal	9SL13570	1	X
2	Led Lens, Clear	9SS23093-1	2	X
3	Output Harness	9SM23501	2	X
4	Tractor Control Harness	9SM23503	1	X
5	USB Input Harness	9SS30466	1	X
6	USB Cable Cover	9SS31791	1	X
7	Work Sense Input Harness	9SM23506	1	X
8	Electrode Sense Input Harness	9SM23507	1	X
9	Trigger Input Harness	9SM23509	1	X
10	E-Stop Switch	9SM20853	1	X
11	#4-40 Locknut Nylon Insert	9SS31350-17	24	X
12	Hex Lock Nut	9ST9187-13	1	X
13	Cable Connector Cap	9SS17062-10	3	X
14	Cap - Cable Connector	9SS17062-12	1	X
15	Self Tapping Screw	9SS8025-80	5	X
16	Water Inlet / Outlet Cover	9SM17894	1	X
17	Thread Forming Screw	9SS9225-99	2	X
18	Boot	9SS18581-2	1	X
19	Pan Head Screw 10-24 X 1/4	9SCF000008	3	X
20	Thread Forming Screw	9SS9225-102	4	X
21	Thread Forming Screw	9SS9225-100	1	X

NOTE: This Parts Manual is provided as an informative guide only. When ordering parts always refer to the Lincoln Electric Parts List.

CASE ASSEMBLY

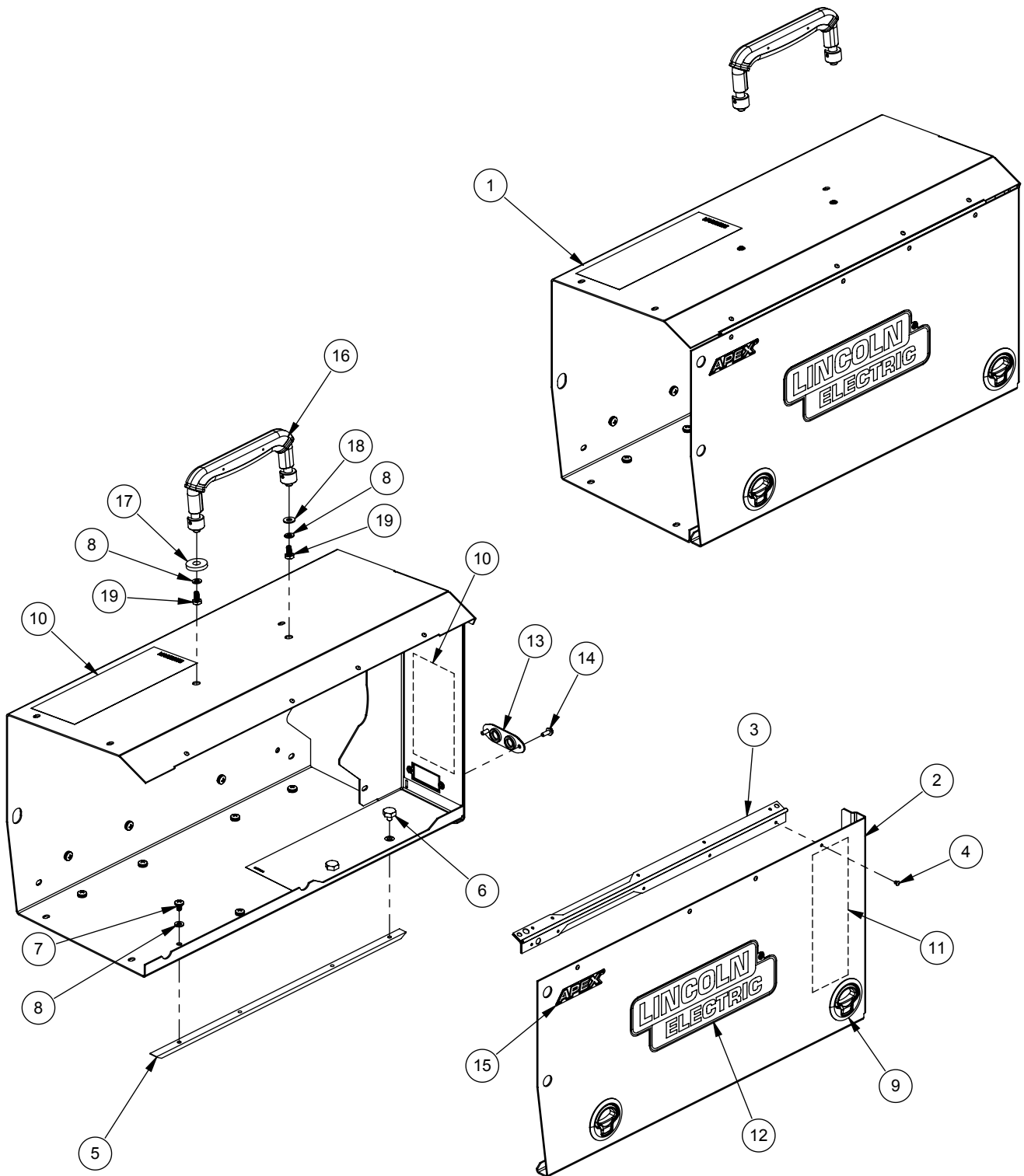

NOTE: This Parts Manual is provided as an informative guide only. When ordering parts always refer to the Lincoln Electric Parts List.

CASE ASSEMBLY

Indicates a change in this printing.

Use only the parts marked "x" in the column under the heading number called for in the model index page.

ITEM	DESCRIPTION	PART NO.	QTY	1
1	Case	9SM23379	1	X
2	Door	9SM23365	1	X
3	Shield & Hinge Assembly	9S9EM21234	1	X
4	Blind Rivet	9SS31751	8	X
5	Skid	9SS20195	4	X
6	Insulated Fastener	9ST15088	2	X
7	Pan Head Screw 1/4-20 X 3/8	9SS8025-17	12	X
8	Lock Washer 1/4	9SE106A-2	14	X
9	Latch	9SM20977	2	X
10	Warning Decal	9SS20601-2	1	X
11	Warning Decal	9SS25536-1	1	X
12	Decal, Le Logo	9SS27368-4	2	X
13	Water Inlet / Outlet Cover	9SM17894	1	X
14	Thread Forming Screw	9SS9225-99	2	X
15	Apex Decal	9SS31752	2	X
16	Handle Assembly	9SS18170	1	X
17	Plain Washer	9SS9262-113	1	X
18	Washer 1/4, Steel, Zinc Plated	9SS9262-98	1	X
19	1/4-20 X 1/2 HHCS	9SCF000012	2	X

NOTE: This Parts Manual is provided as an informative guide only. When ordering parts always refer to the Lincoln Electric Parts List.

REAR PANEL ASSEMBLY

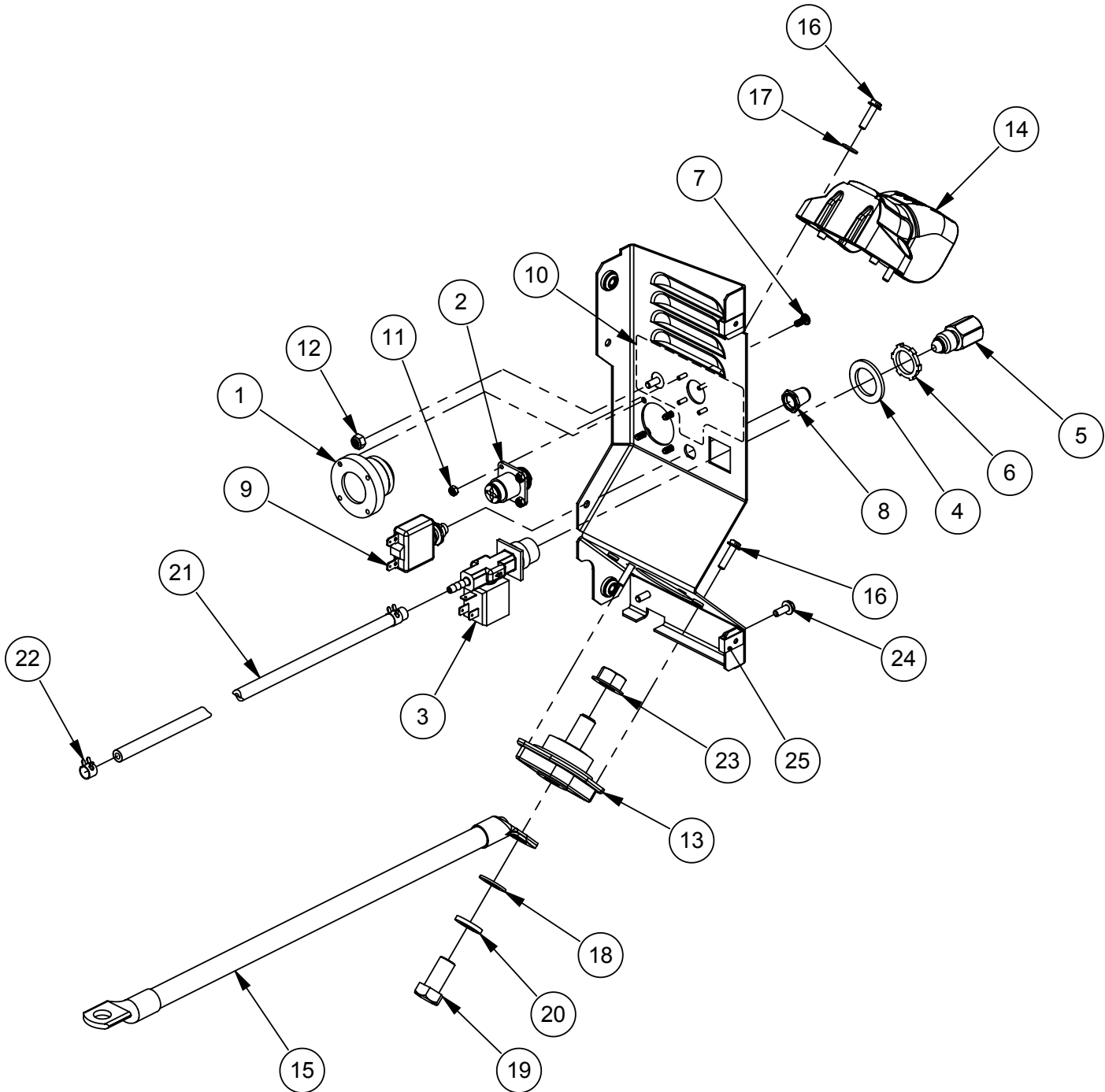

NOTE: This Parts Manual is provided as an informative guide only. When ordering parts always refer to the Lincoln Electric Parts List.

REAR PANEL ASSEMBLY

Indicates a change in this printing.

Use only the parts marked "x" in the column under the heading number called for in the model index page.

ITEM	DESCRIPTION	PART NO.	QTY	1
1	Input Harness	9SM23381	1	X
2	Work Sense Output Harness	9SS31739	1	X
3	Solenoid Valve	9SM17294-8	1	X
4	Plain Washer	9SS9262-149	1	X
5	Shielding Gas Filter	9SS28863	1	X
6	Conduit Locknut	9ST14370-1	1	X
7	Pan Head Screw	9SCF000006	4	X
8	Sealing Boot	9SS22061-3	1	X
9	Circuit Breaker 10A	9ST12287-20	1	X
10	Rear Decal	9SL13568	1	X
11	#4-40 Locknut Nylon Insert	9SS31350-17	4	X
12	Hex Lock Nut	9ST9187-13	1	X
13	Output Terminal Assembly	9SS16656-4	1	X
14	Output Stud Cover	9SG6864	1	X
15	Internal Power Cable	9SS31753	1	X
16	Self Tapping Screw	9SS9225-100	4	X
17	Plain Washer	9SS9262-184	1	X
18	Plain Washer	9SS9262-80	1	X
19	1/2-13 X 1.00 HHCS	9SCF000021	1	X
20	Lock Washer	9SE106A-15	1	X
21	Gas Hose	9ST10642-265	1	X
22	Hose Clamp	9ST13777-8	2	X
23	Output Stud Nut	9ST3960	1	X
24	Thread Forming Screw	9SS9225-99	2	X
25	Speed Nut	9ST11525-8	2	X

NOTE: This Parts Manual is provided as an informative guide only. When ordering parts always refer to the Lincoln Electric Parts List.

CONTROL BOX ASSEMBLY

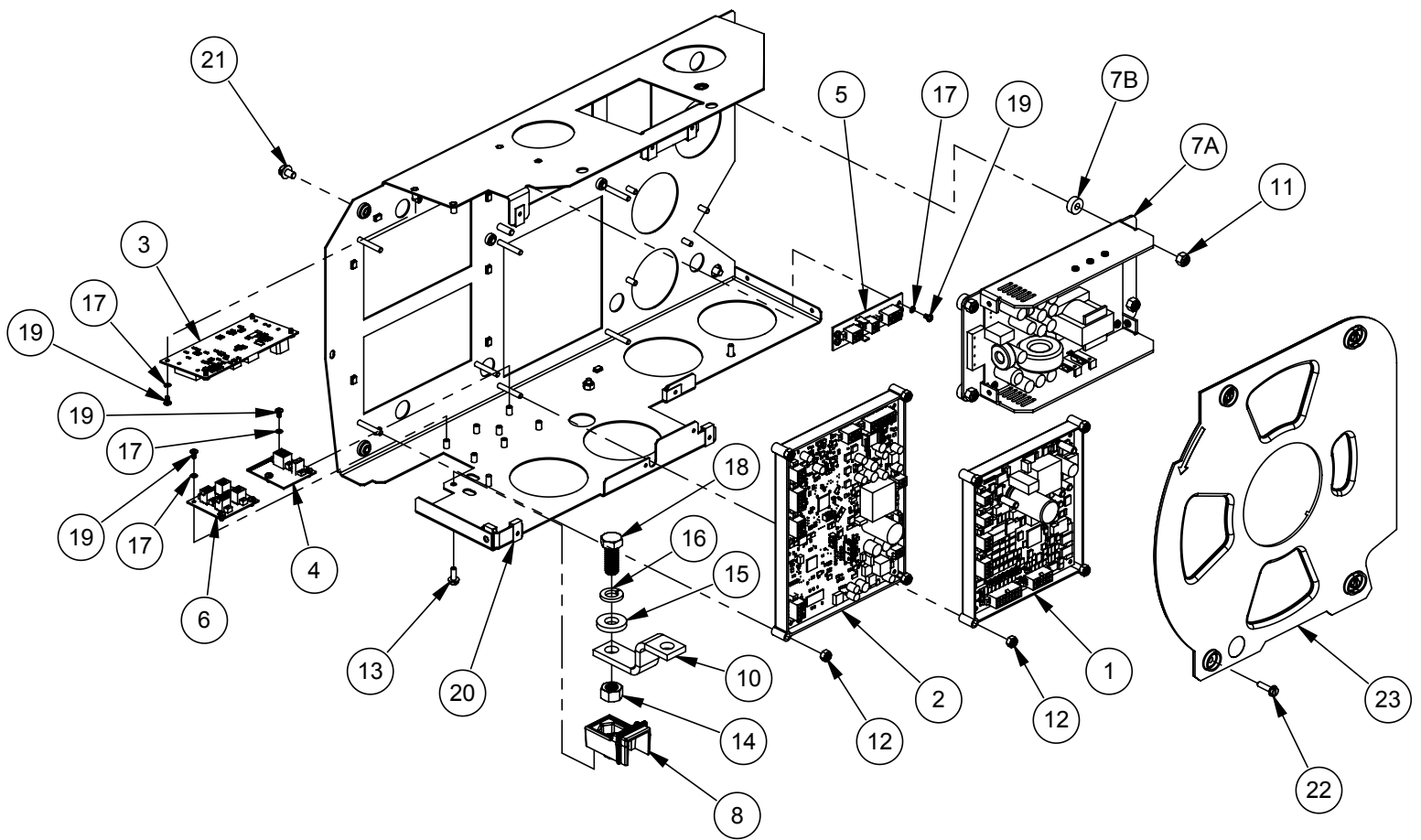

NOTE: This Parts Manual is provided as an informative guide only. When ordering parts always refer to the Lincoln Electric Parts List.

CONTROL BOX ASSEMBLY

Indicates a change in this printing.

Use only the parts marked "x" in the column under the heading number called for in the model index page.

ITEM	DESCRIPTION	PART NO.	QTY	1	2
1	Wire Drive PC BC Assembly	9SS28626	1	X	X
2	Can Open Bridge PCB Assembly	9SS30301	1	X	•
2	Can Open Bridge PCB Assembly	9SS31338	1	•	1
3	USB PC Board Assembly	9SS31189	1	X	X
4	Voltage Sense PCB	9SM19540-3	1	X	X
5	40V 24V Distribution Board	9SS31010-1	1	X	X
6	Arclink Distribution Board	9SS31042-1	1	X	X
7	Power Supply Kit, Includes:	9SS31750	1	X	X
7A	Power Supply	NSS	1	X	X
7B	Aluminum Spacer	NSS	4	X	X
8	Insulated Mounting Block	9SM21096	1	X	X
10	Terminal Block Lead	9SS31735	1	X	X
11	1/4-20 Locknut Nylon Insert	9ST9187-16	4	X	X
12	#10-24 Locknut Nylon Insert	9ST9187-13	9	X	X
13	Thread Forming Screw	9SS9225-99	3	X	X
14	1/2-13 Hex Nut	9SCF000027	1	X	X
15	Plain Washer	9SS9262-80	1	X	X
16	Lock Washer 1/2	9SE106A-15	1	X	X
17	Lock Washer #6	9SE106A-13	15	X	X
18	Hex Head Fastener	9SCF000030	1	X	X
19	Self Tapping Screw	9SS8025-80	15	X	X
20	Speed Nut	9ST11525-8	7	X	X
21	Thread Forming Screw	9SS9225-102	6	X	X
22	Self Tapping Screw	9SS9225-100	4	X	X
23	Control Box Cover	9SM21011-2	1	X	X

NOTE: This Parts Manual is provided as an informative guide only. When ordering parts always refer to the Lincoln Electric Parts List.

SPINDLE & MAST ASSEMBLY

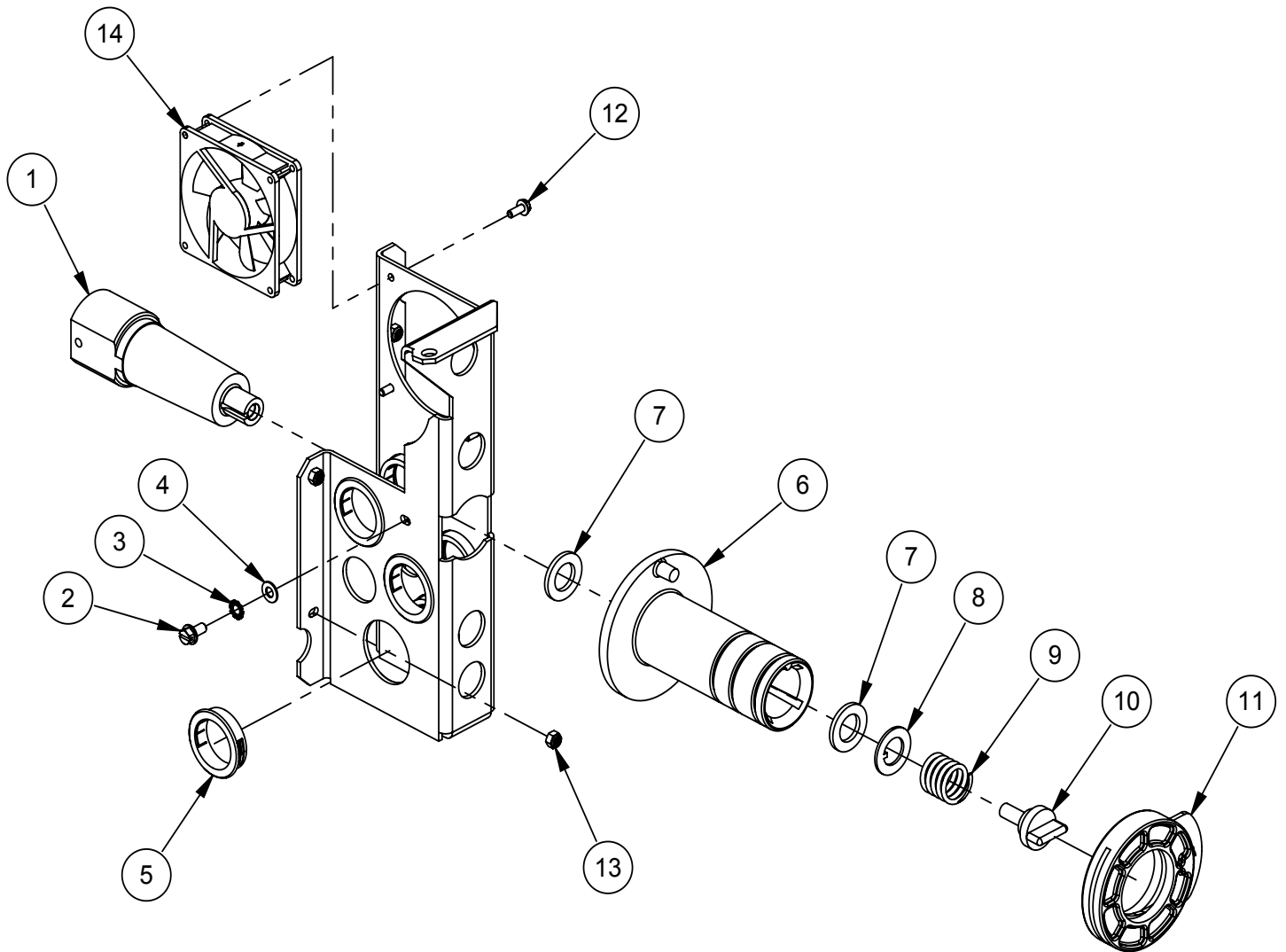

NOTE: This Parts Manual is provided as an informative guide only. When ordering parts always refer to the Lincoln Electric Parts List.

SPINDLE & MAST ASSEMBLY

Indicates a change in this printing.

Use only the parts marked "x" in the column under the heading number called for in the model index page.

ITEM	DESCRIPTION	PART NO.	QTY	1
1	Spindle Shaft	9SM20990-1	1	X
2	Thread Forming Screw	9SS9225-68	2	X
3	Tooth Lock Washer	9ST9860-6	2	X
4	Plain Washer	9SS9262-23	2	X
5	Bushing	9ST12380-1	6	X
6	Spindle	9SL10560-2	1	X
7	Friction Washer	9SS17435-3	2	X
8	Keyed Washer	9ST12965-2	1	X
9	Compression Spring	9ST11862-14	1	X
10	Thumb Screw	9ST14813-A	1	X
11	Retaining Collar Assembly	9SS23811	1	X
12	Thread Forming Screw	9SS9225-99	4	X
13	Hex Lock Nut	9ST9187-13	1	X
14	Fan Harness	9SS30460	1	X

NOTE: This Parts Manual is provided as an informative guide only. When ordering parts always refer to the Lincoln Electric Parts List.

WIRE DRIVE ASSEMBLY (1 of 2)

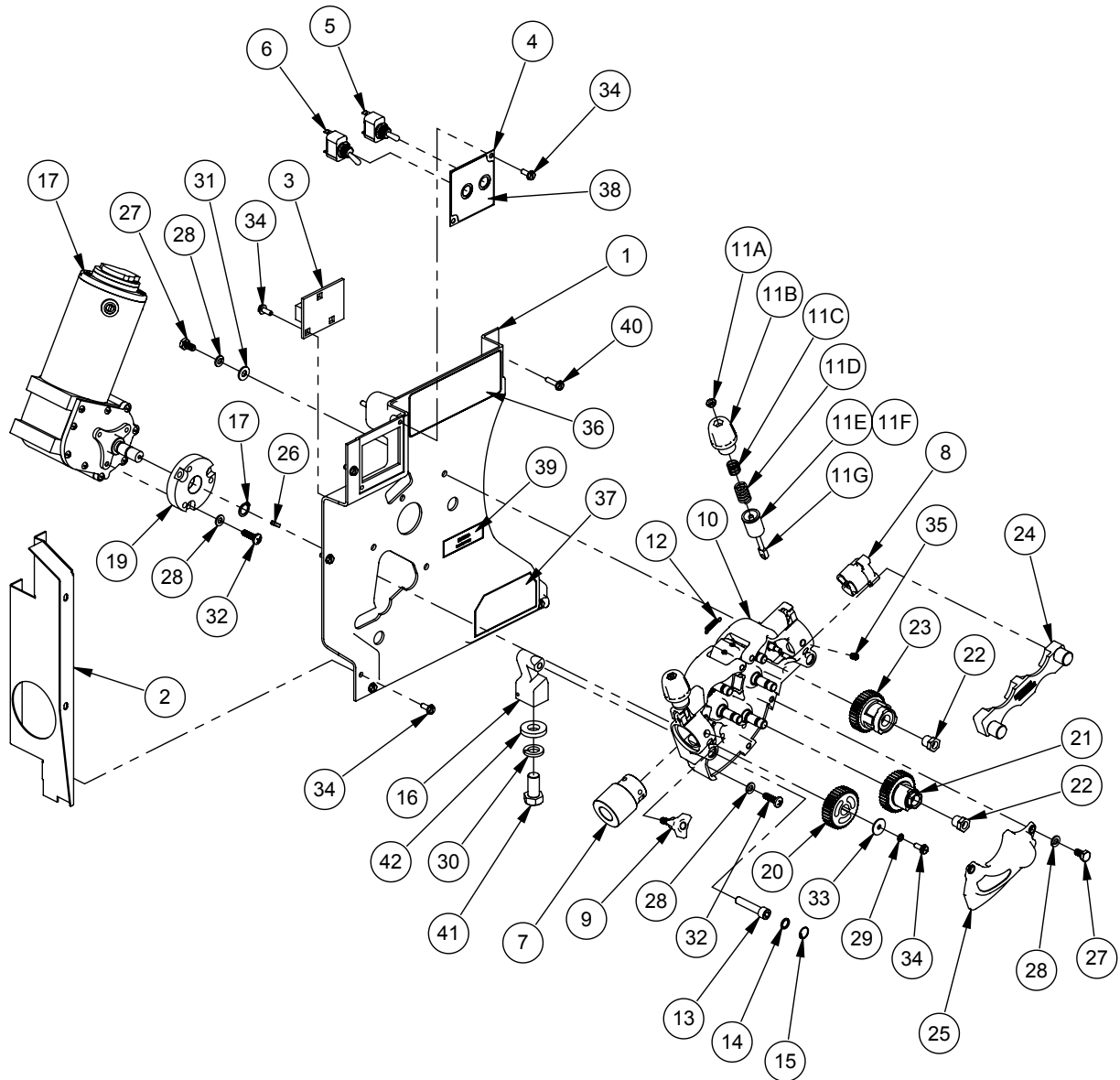

NOTE: This Parts Manual is provided as an informative guide only. When ordering parts always refer to the Lincoln Electric Parts List.

WIRE DRIVE ASSEMBLY

Indicates a change in this printing.

Use only the parts marked "x" in the column under the heading number called for in the model index page.

ITEM	DESCRIPTION (1 OF 2)	PART NO.	QTY	1
1	Wire Drive Panel	9SM23321	1	X
2	Case Side	9SM23367	1	X
3	Tach Interface PC BD Assembly	9SL11355-2	1	X
4	Switch Panel	9SS31736	1	X
5	Switch, Toggle, Spdt	9ST10800-49	1	X
6	Toggle Switch	9ST13562-1	1	X
7	Gun Receiver Bushing	K1500-3	1	X
8	Ball Housing	9SM18946	1	X
9	Three Arm Knob	9SS31741	1	X
10	Feedplate Assembly	9SM23377	1	X
11	Tension Arm Assembly	9SM20593-1	2	X
11A	#10-24HN	9SCF000010	1	X
11B	Tension Arm Cap	9SS26358-1	1	X
11C	Spring	9ST11862-69	1	X
11D	Spring	9ST11862-68	1	X
11E	Pressure Arm Decal	9ST13086-204	1	X
11F	Base	9SS26359-1	1	X
11G	Shaft	9SS26360-1	1	X
12	Torsion Spring	9ST11862-64	1	X
13	Socket Head Cap Screw	9ST9447-112	1	X
14	Plain Washer	9SS9262-167	1	X
15	Retaining Ring	9SS9776-69	1	X
16	Connector Bar	9SS31749	1	X
17	Motor Gearbox Assembly	9SL12604-2	1	X
18	Retaining Ring	9SS9776-3	1	X
19	Motor Adapter	9SS27547	1	X
20	Drive Gear	9SM19870-1	1	X

NOTE: This Parts Manual is provided as an informative guide only. When ordering parts always refer to the Lincoln Electric Parts List.

WIRE DRIVE ASSEMBLY (2 of 2)

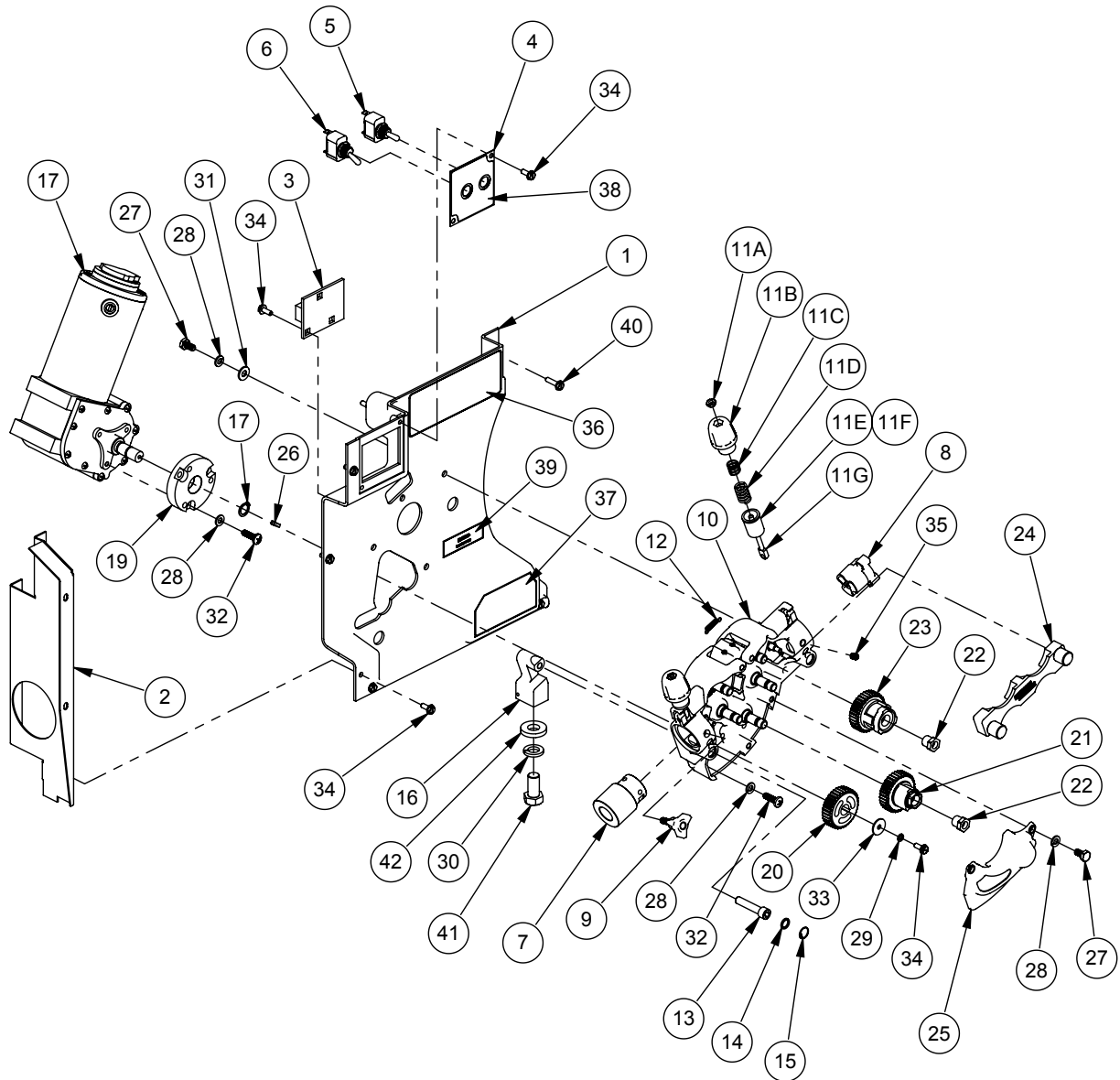

NOTE: This Parts Manual is provided as an informative guide only. When ordering parts always refer to the Lincoln Electric Parts List.

WIRE DRIVE ASSEMBLY

Indicates a change in this printing.

Use only the parts marked "x" in the column under the heading number called for in the model index page.

ITEM	DESCRIPTION (2 OF 2)	PART NO.	QTY	
21	Drive Hub Bearing Assembly	9SS31815	1	X
22	Drive Hub Retainer	9SS25403	5	X
23	Drive Hub Assembly	9SS25638-1	1	X
24	Wire Guide Assembly Outer 4 Roll	KP2071-1	1	X
25	Gear Cover Casting	9SM20399	1	X
26	Woodruff Key	9S#404	1	X
27	1/4-20 X .50 HHCS	9SCF000012	7	X
28	Lock Washer 1/4	9SE106A-2	13	X
29	Lockwasher #10	9SE106A-1	1	X
30	Lock Washer 1/2	9SE106A-15	1	X
31	Plain Washer	9SS9262-23	4	X
32	Metric Pan Head Screw	9ST14731-18	6	X
33	Plain Washer	9SS9262-66	1	X
34	Thread Forming Screw	9SS9225-99	9	X
35	Set Screw	9SS11604-21	1	X
36	Warning And Adjustment Decal	9SM23328	1	X
37	Rating Plate	9SM23327	1	X
38	Toggle Switch Decal	9SM23329	1	X
39	Maxtrac Decal	9SS26310	1	X
40	Thread Forming Screw	9SS9225-100	4	X
41	1/2-13 X 1.00 HHCS	9SCF000021	1	X
42	Plain Washer	9SS9262-80	1	X

NOTE: This Parts Manual is provided as an informative guide only. When ordering parts always refer to the Lincoln Electric Parts List.

WIRE HARNESSES

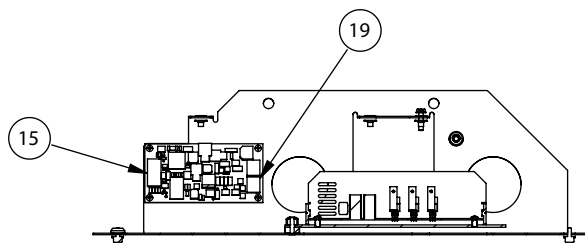
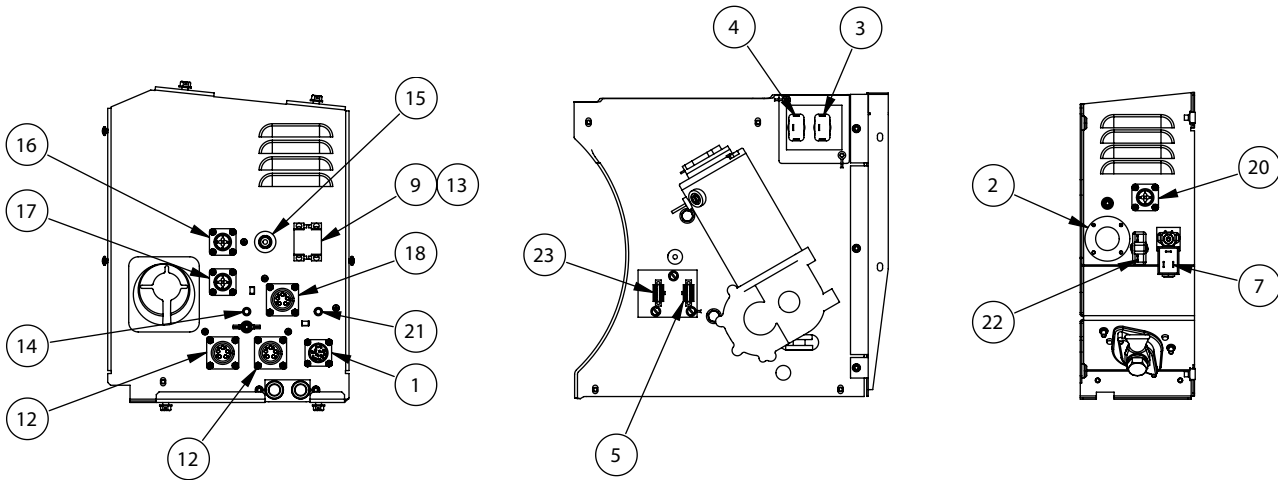

SECTION A-A

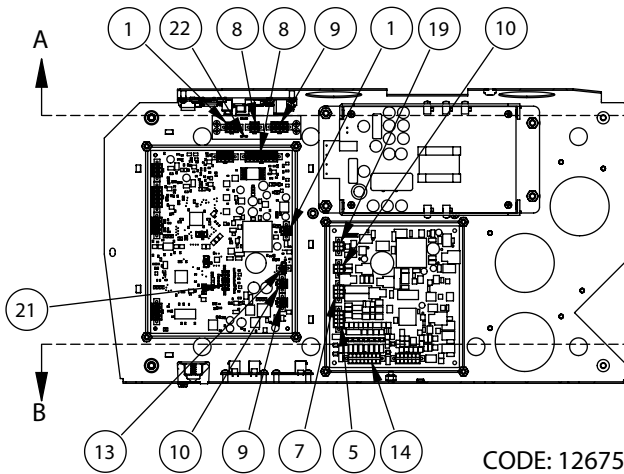

CODE: 12675

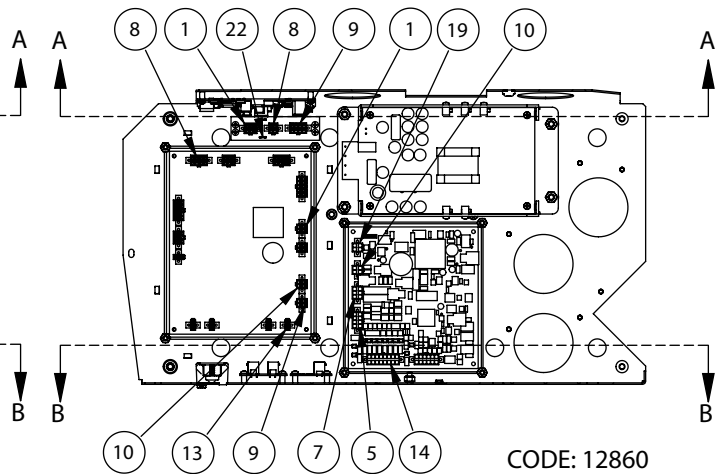

CODE: 12860

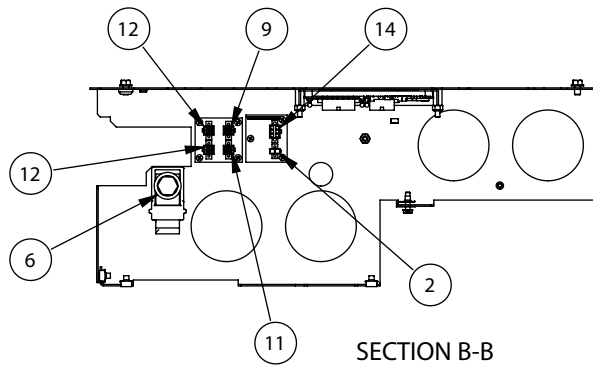

SECTION B-B

NOTE: This Parts Manual is provided as an informative guide only. When ordering parts always refer to the Lincoln Electric Parts List.

WIRE HARNESES

Indicates a change in this printing.

Use only the parts marked "x" in the column under the heading number called for in the model index page.

ITEM	DESCRIPTION	PART NO.	QTY	1	2
1	Tractor Control Harness	9SM23503	1	X	X
2	Input Harness	9SM23381	1	X	X
3	Voltage Sense Switch Harness	9SM23382	1	X	X
4	Wire Gas Switch Harness	9SM23383	1	X	X
5	Tach Output Harness	9SM23384	1	X	X
6	Electrode Sense Bus Bar Harness	9SM23385	1	X	X
7	Motor Solenoid Harness	9SM23386	1	X	X
8	Fan Monitor Harness	9SM23387	1	X	•
8	Fan Monitor Harness	9SM23712	1	•	X
9	Power Input Harness	9SM23388	1	X	X
10	ARCLINK® Jumper Harness	9SM23389-05	1	X	X
11	ARCLINK Extension Harness	9SM23390-16	1	X	X
12	Output Harness	9SM23501	2	X	X
13	Estop Logic Harness	9SM23502	1	X	X
14	Wire Feed Aux Harness	9SM23504	1	X	X
15	USB Input Harness	9SM23505	1	X	X
16	Work Sense Input Harness	9SM23506	1	X	X
17	Electrode Sense Input Harness	9SM23507	1	X	X
18	Trigger Input Harness	9SM23509	1	X	X
19	Usb Jumper Harness	9SS30466	1	X	X
20	Work Sense Output Harness	9SS31739	1	X	X
21	LED Harness	9SS31754	1	X	•
21	LED Harness	9SS31032-11	1	•	X
22	Circuit Breaker Harness	9SS31755	1	X	X
23	Motor Harness	9SM21561-2	1	X	X

NOTE: This Parts Manual is provided as an informative guide only. When ordering parts always refer to the Lincoln Electric Parts List.

CUSTOMER ASSISTANCE POLICY

The business of The Lincoln Electric Company is manufacturing and selling high quality welding equipment, consumables, and cutting equipment. Our challenge is to meet the needs of our customers and to exceed their expectations. On occasion, purchasers may ask Lincoln Electric for advice or information about their use of our products. We respond to our customers based on the best information in our possession at that time. Lincoln Electric is not in a position to warrant or guarantee such advice, and assumes no liability, with respect to such information or advice. We expressly disclaim any warranty of any kind, including any warranty of fitness for any customer's particular purpose, with respect to such information or advice. As a matter of practical consideration, we also cannot assume any responsibility for updating or correcting any such information or advice once it has been given, nor does the provision of information or advice create, expand or alter any warranty with respect to the sale of our products.

Lincoln Electric is a responsive manufacturer, but the selection and use of specific products sold by Lincoln Electric is solely within the control of, and remains the sole responsibility of the customer. Many variables beyond the control of Lincoln Electric affect the results obtained in applying these types of fabrication methods and service requirements.

Subject to Change – This information is accurate to the best of our knowledge at the time of printing. Please refer to www.lincolnelectric.com for any updated information.



THE LINCOLN ELECTRIC COMPANY

22801 St. Clair Avenue • Cleveland, OH • 44117-1199 • U.S.A.
Phone: +1.216.481.8100 • www.lincolnelectric.com